

PS2.03 TVR/QVR20 Series Touchscreen VAV Controllers



The TVR/QVR Series Controllers have been designed to be wall mounted VAV (Variable Air Volume) controllers in room spaces. The controllers are suitable for both pressure independent and pressure dependent VAV control with additional control logic for zone heating or cooling. Optional built-in CO₂, humidity and VOC measurements and control logic can expand the control functionality further. The controllers can also connect direct to Senticon's DPT50 Pressure Sensors.

The xVR20 series controllers are wall surface mounted. xVR12 series controllers are Slim Line flush mounted with additional IOs to standard wall mounting boxes.

The room controllers have an optional sharp colour touchscreen display with glass front that provides intuitive user interface. An optional PIR sensor is available for occupancy mode. The controllers are mounted on the wall surface directly or to standard wall mounting boxes. The controllers have built-in Modbus RTU or BACnet MS/TP communication that allow interaction to the BMS systems. Optional Bluetooth wireless interface provides Smart Phone App interface (iOS). LoraWan option allows integration wirelessly to the LoraWan systems.

Features

- Advanced Room Controllers for wide variety of VAV (variable air volume) and other control applications.
- Multi- and Single Stage PI Control Loops provide accurate control of Temperature, Humidity, CO₂, VOC or combination of them with pressure independent flow control logic, dew point, maximum demand etc. functions
- BACnet MS/TP and Modbus RS485 RTU with up to 60V industrial isolation on RS485 for system integration
- Optional LoraWan® long-range wireless communication interface
- 2.4" Colour Touchscreen for Indications, User Actions and Alarms. Blank version available for discreet installations
- QVR20 Series have Built-in CO₂ Measurement and Control
- 1 x Flow/Pressure Sensor Input (Pa, l/s, m³/h, cfm) - flow conversion when Pressure Sensors are used
- 1 x Universal Inputs (temperature/0-10V/digital) e.g. remote temperature measurement
- 4 x Analogue 0..10Vdc Outputs, max 2mA
- Configuration wirelessly through Smart Config Windows Software or Smart Phone iOS App (via Built-In Bluetooth or using Bluetooth Dongles). SmartView SmartPhone App for device interrogation for end users.

- Optional 24V pilot relay (RL-option) allows equipment switching locally
- Available in both White and Black. The display has number of different skin colour options for customisation.

Technical Specifications

Power Supply:	Power:	24Vac/dc -10%/+15%, max 80mA with display
Measurements:	Temperature (All Models)	
	Range:	0..50° (32..122°F)
	Accuracy:	+/-0.5°C
	CO2 (QVR Models)	
	Range:	0..10,000ppm
	Accuracy:	+/-50ppm + 5% of the reading
	Humidity (Option)	
	Range:	0..100%rH
	Accuracy:	+/-2%rH (within 20 to 80%rH)
	VOC (Volatile Organic Compound) (Option)	
Range:	0..500 (Air Quality Index)	
PIR Movement (Option)		
Type/Range:	Passive Infrared Movement Detection, Range up to 5m	
Inputs:	Flow/Pressure Input:	1 x Flow/Pressure Input - 0-10Vdc, optional flow calculation from k-value
	Universal Input:	1 x Universal Inputs - RI/AI/DI Application Selected RI = NTC10 Measurement / Resistive AI = 0..10Vdc Input DI = Digital Volt-Free Input
Outputs:	Analogue Outputs:	4 x 0..10Vdc, min. load resistance >5 kOhms (max. 2mA @ 10V)
	Relay Outputs:	RL Option: 1 x 24V Pilot Relay, max 0.25A
Communication:	Physical Interface	1 x RS485 driver with up to 60V industrial Isolation, recommended max 63 devices
	Protocol:	Modbus RTU or BACnet MS/TP (order relevant model)
	Addressing:	Via Bitswitch: 1..127 Via Software: 1..247 for Modbus, 1..127 for BACnet MS/TP
	Settings:	Baud Rate: 9600/19200/38400/76800 (bitswitch), 57600/115200 (software) Modbus Parity: None/Even/Odd, Modbus Stop Bits: 1 or 2
Wireless Interface:	Bluetooth (Option):	Bluetooth Low Energy - iOS Smart Phone App Interface
	LoraWan (Option):	LoraWan® Wireless Interface (EU868, other bands available on request) Encrypted LoraWan® 1.0.3 Class C Device with secure OTAA activation with IPEX antenna for long-range communication.
Display:	Option	Optional 2.4" Full Colour Display with Glass Overlay, 240 x 320px
Mechanical:	Wiring Terminals:	Rising Cage Screw Terminals, 0.2 to 2.5mm ² / 26 to 12 AWG
	Enclosure:	ABS ULV0 Plastics - White or Black
	Mounting:	Standard: Wall or Junction Box Mounting (60mm screw distance) Slimline: Junction Box Mounting (60mm screw distance)
	Dimensions	Standard: W86 x H86 x D24mm SlimLine: W86 x H86 x D14mm (Surface Part) W86 x H86 x D39mm (Total)
Country of Origin:		United Kingdom

Model Selection

Refer to the below table to select the required model. The part number offers descriptive method for the product and options selection, and the SKU# number provides unique reference number. It is possible to order products using either.

Part Number		SKU# Number						
Example	QVR20-BAC-TS-OE-W	6100	2	02	03	0	0	2
Product Name		Product		Product Options				
TVR20	Room VAV Controller, 1FLOW, 1UI, 4AO	6000						
QVR20	Room VAV Temperature and CO2 Controller, 1FI, 1UI, 4AO	6100						
TVR22	Slimline Room VAV Controller, 1FLOW, 1UI, 4AO	6400						
QVR22	Slimline Room VAV Temperature and CO2 Controller, 1FI, 1UI, 4AO	6500						
Serial Communication Option								
	No RS485 Communications		0					
MOD	Modbus RS485		1					
BAC	BACnet MS/TP		2					
Interface and Wireless Options								
	No Interface				00			
TS	Colour Capacitive Touchscreen				02			
BLE	Bluetooth App Interface				03			
TS-BLE	Touchscreen and Bluetooth				05			
LRA	LoraWan Wireless Interface, EU868Mhz				06			
TS-LRA	LoraWan Wirelss Interface EU868MHz with Touchscreen				08			
Measurement Options								
	No Extra Measurements					00		
RH	Relative Humidity					01		
RH-VOC	Volatile Organic Compound and Humidity					02		
OE	Passive Infrared Movement (PIR)					03		
RH-OE	Relative Humidity and Movement (PIR)					04		
RH-VOC-OE	VOC, Relative Humidity and Movement (PIR)					05		
Output Options								
	No Output Options						00	
RL	24V Relay Output						01	
Region (LoraWan)								
	Non Lora or EU868MHz LoraWan							0
US	US915MHz LoraWan							1
AS	AS923MHz LoraWan							2
IN	IN815MHz LoraWan							3
Colour Options								
B	Black							1
W	White							2

Wiring Connections

TVR20/QVR20 CONTROLLER WIRING

The diagram below illustrates the wiring connections to the controllers

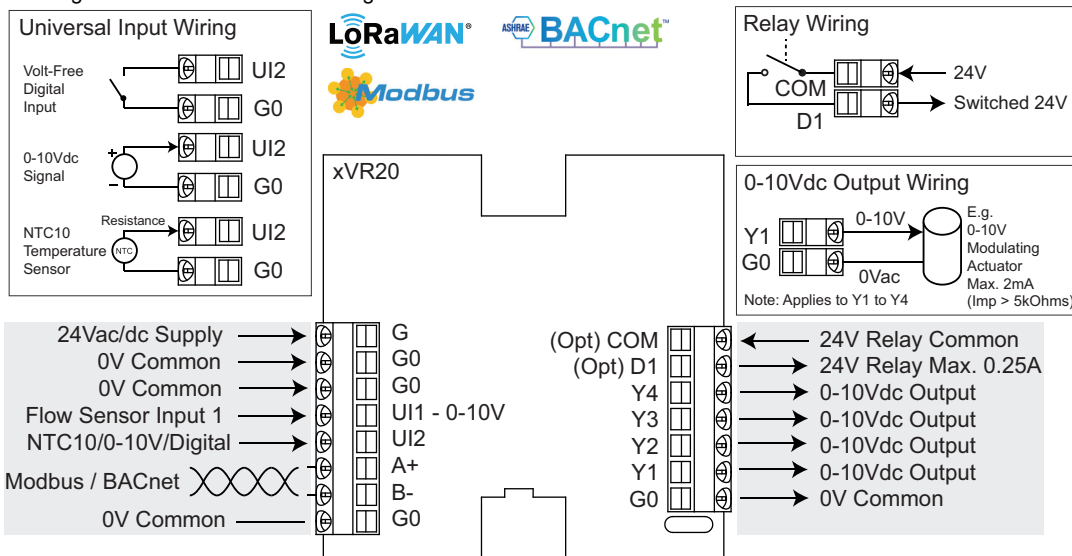

Terminal	Description
G	24Vac/dc -10/+15% Supply
G0	0V Common
UI1	Flow Sensor Input 1 (Flow/Pressure)
UI2	NTC10/0-10V/Volt-Free Digital Input 2
A+	Modbus / BACnet RS485 A+
B-	Modbus / BACnet RS485 B-
G0	0V Common

Terminal	Description
COM	24V Relay Common (Option)
D1	24V Relay Max 0.25A (Option)
Y4	0-10Vdc Output max. 2mA
Y3	0-10Vdc Output max. 2mA
Y2	0-10Vdc Output max. 2mA
Y1	0-10Vdc Output max. 2mA
G0	0V Common

TVR22/QVR22 CONTROLLER WIRING

xCR22 series controllers are flush mounted to junction box. The diagrams below illustrate the wiring.

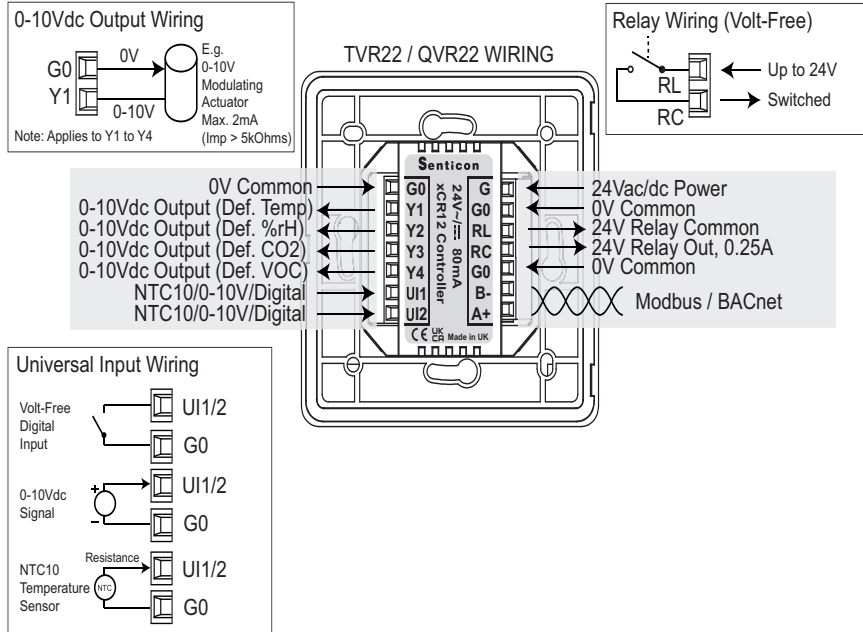

Terminal	Description
G0	0V Common
Y1	0-10Vdc Output 1, max. 2mA (Default: Heating Stage 1)
Y2	0-10Vdc Output 2, max. 2mA (Default: Cooling Stage 1)
Y3	0-10Vdc Output 3, max. 2mA (Default: EC Fan Speed)
Y4	0-10Vdc Output 4, max. 2mA (Default: CO2 Control)
UI1	NTC10/0-10V/Volt-Free Digital Input 1
UI2	NTC10/0-10V/Volt-Free Digital Input 2

Terminal	Description
G	24Vac/dc -10/+15% Supply Note: Triacs need 24Vac
G0	0V Common
RL	24V Relay (RL-option)
RC	24V Relay Common (RL-option)
G0	0V Common
B-	Modbus / BACnet RS485 B-
A+	Modbus / BACnet RS485 A+

WIRING GUIDELINES

In order to wire the device, remove the front cover by pressing the clip on the bottom of the display e.g. using a flat headed screwdriver. Be careful not to use excess force. Whilst pressing the clip lift the front cover from the bottom edges of the enclosure.

Make sure that power is switched off and carry out wiring according to the wiring connections drawing and local wiring guidelines. Insert the front cover and power up the device.

NOTE: For opening and mounting the enclosure please refer to the Dimensions and Installation Chapter.

Controller Applications

The TVR20/QVR controllers have flexible software design that allows them to be tailored to a wide range of VAV and room control applications. Each controller can be configured from default settings using the Smart Configuration tools or via the network. The unused inputs and outputs are available for Building Management Systems for additional control functions.

DEFAULT APPLICATION - PRESSURE INDEPENDENT VAV WITH RE-HEAT USING AIR FLOW SENSOR

As factory default, the controller has been configured to provide pressure independent VAV control with reheat using external airflow sensor (m³/h, l/s). The diagram below illustrates this application and wiring connections.

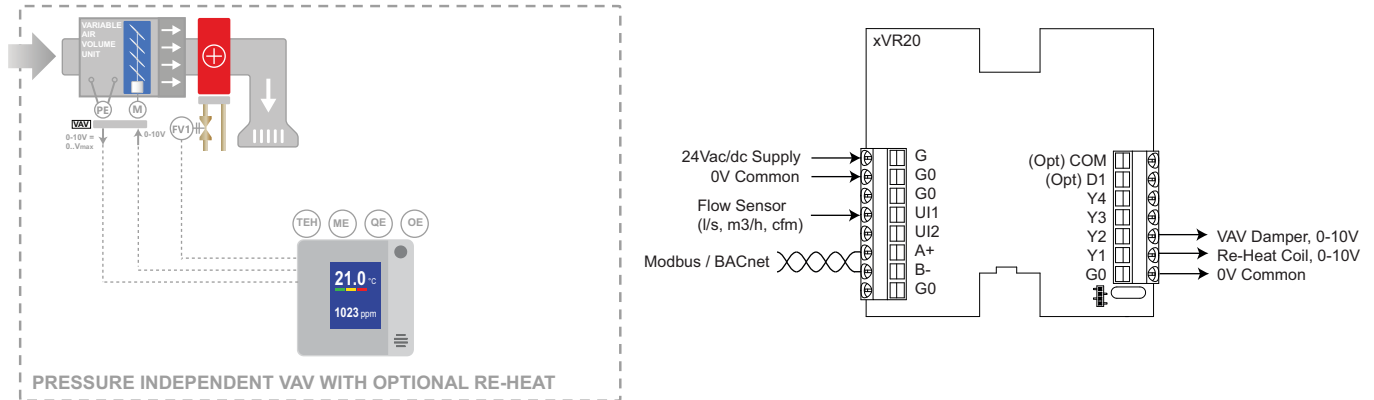

To tailor the controller to the specific VAV Box size, the following steps are required:-

FLOW SENSOR INPUT

- Set 523 - *Sensor Value Min.* to match the Flow Sensor Min. Flow @ 0Vdc
- Set 524 - *Sensor Value Max.* to match the Flow Sensor Max Flow @ 10Vdc

FLOW CONTROL LOOP

- Set 796 - *Min Flow Setpoint* to the required min. flow setting (use the same units / scaling as with the Flow Input 1 e.g. l/s, m³/h or cfm)
- Set 797 - *Max. Flow Setpoint* to the required mx. air flow through the VAV box
- If the application has re-heat coil fitted, set the 798 - *Heating Flow Setpoint* to the required flow when the VAV box is heating

NOTE: If the Flow Reading is required to be displayed e.g. in the location 4 on the touchscreen, set the 641 - *Location 4: 4* = Flow Input 1, 642 - *Description: 24* = Flow and 643 - *Unit: 10* = l/s, 11 = m³/h, or 12 = cfm (depending on the units used)

PRESSURE INDEPENDENT VAV WITH RE-HEAT USING DIFFERENTIAL AIR PRESSURE SENSOR

In this application the QVR20/TVR20 controllers offer pressure independent VAV control using external pressure sensors. The controllers are typically connected to Senticon's DPT50 range pressure sensors. These give either -20..+250Pa or -20 to 500Pa pressure measurement range. The xVR20 series controllers then calculate the current flow rate (m³/h, l/s, cfm)

and modulate the damper actuator output accordingly to maintain the required flow rate. The required flow rate is set by the temperature/air quality control loop. The diagram below illustrates this application.

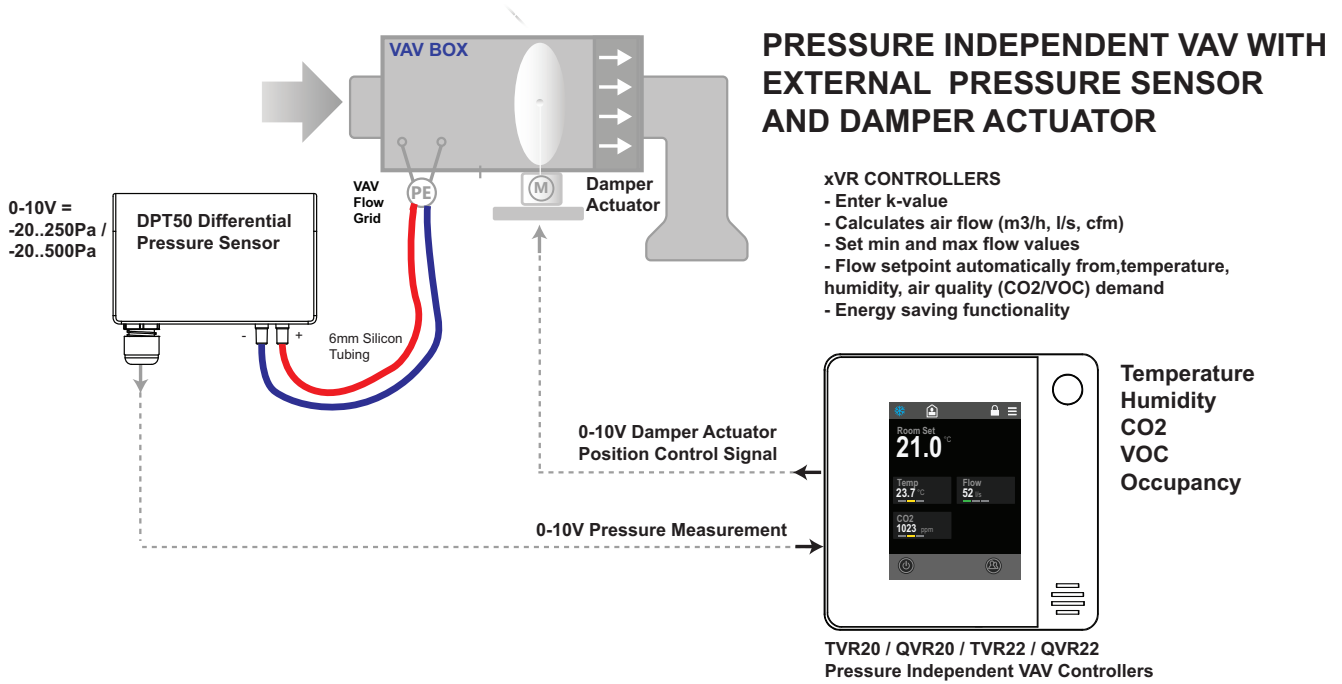

FLOW INPUT AS PRESSURE INPUT

The Flow input is configured to measure the pressure using 0..10V input.

- Set 523: *Sensor Value Min.* to match the Pressure Sensor Sensor Min. Pressure, typically -20Pa with Senticon DPT50
- Se 524: *Sensor Value Max.* to match the Pressure Sensor Sensor Max. Pressure, with Senticon DTP50 sensors 250/500Pa

Once the pressure measurement has been configured, then this is converted to the Flow Measurement (l/s, m3/h. cfm) using the K-value of the VAV Box. The k-value is obtained from the VAV box manufacturer.

- Set 527: *K Value Unit* and 529: *K Value* to match the values given by the VAV Box manufacturer

<ul style="list-style-type: none"> LIVE VIEW INPUTS OUTPUTS DEMAND SIGNALS INPUT / OUTPUT SETTINGS <ul style="list-style-type: none"> FLOW & PRESSURE SENSOR UNIVERSAL INPUT & TEMPERATURE ANALOGUE OUTPUTS DIGITAL INPUTS DIGITAL OUTPUT CALIBRATION SETTINGS DISPLAY SETTINGS CONTROL SYSTEM 	<ul style="list-style-type: none"> 516 Sensor Voltage Min. <input type="text" value="0.0"/> 517 Sensor Voltage Max. <input type="text" value="10.0"/> 523 Sensor Value Min. <input type="text" value="-20"/> 524 Sensor Value Max. <input type="text" value="250"/> 527 K Value Unit <input type="text" value="1: l/s"/> 529 K Value <input type="text" value="7.2"/> 515 Flow Unit <input type="text" value="0: l/s"/> 514 Flow Cut-off <input type="text" value="0.0"/>
--	---

The *Live View 510: Flow Input 1* displays the flow measurement in units set by 515 : *Flow Unit*. The BACnet AV(5) Flow Object also shows the flow measurement in units set on the 515.

<ul style="list-style-type: none"> LIVE VIEW INPUTS OUTPUTS DEMAND SIGNALS INPUT / OUTPUT SETTINGS <ul style="list-style-type: none"> FLOW & PRESSURE SENSOR UNIVERSAL INPUT & TEMPERATURE ANALOGUE OUTPUTS DIGITAL INPUTS DIGITAL OUTPUT CALIBRATION SETTINGS DISPLAY SETTINGS 	<ul style="list-style-type: none"> 400 Temperature Sensor (°C/°F) <input type="text" value="30.6"/> 401 Humidity Sensor (%rH) <input type="text" value="48.1"/> 402 CO2 Sensor (ppm) <input type="text" value="467"/> 403 VOC Sensor (index) <input type="text" value="103"/> 404 Dew Point (°C/°F) <input type="text" value="20.3"/> 410 Flow Input 1 <input type="text" value="29.8"/> 419 Differential Pressure (Pa) <input type="text" value="17.2"/>
---	--

Control Functions

CONTROL MODES

The controllers have three control modes:-

- Occupied (Comfort)
- Unoccupied (Relaxed)
- Off (Night)

The controller operating mode is changed via the touchscreen, via PIR Occupancy Sensor (-OE option), via hardware inputs, via Modbus/BACnet network or via SmartPhone app (iOS). On transition from Occupied to Unoccupied/Off modes the Multi-Stage and Humidity Loop user setpoint adjustments can be automatically reset to nominal values (enable *Reset User Adjustment* parameter)

NOTE: The control mode change happens when the controller sees the transition on the state of the command signal. This means that e.g if Digital Input 1 (UI1) overrides the controller to unoccupied mode, the mode can be changed e.g. via network regardless of the current DI1 state.

NOTE: The PIR movement sensor (-OE option) changes the controller mode both with On and Off transitions.

The control loop outputs (demand signals) are set in different modes as per the below table.

Control Mode	Heating and Cooling Stages 1/2/3 Demand	Flow Control Loop Demand	Air Quality CO2 and VOC Control Demand	Humidity and Dehumidty Control Demand, Fan Demand
Occupied	Based on control loop with occupied deadzone settings	Based on control loop	Based on control loop	Based on control loop
Unoccupied	Based on control loop with unoccupied deadzone settings	Based on control loop	Based on control loop	Based on control loop
Off	0% (Frost logic enables heating stages to 100%)	0%	0%	0%

NOTE: On power up the controller starts in Occupied (Comfort) mode.

MULTI-STAGE TEMPERATURE CONTROL

The controllers have multi-stage temperature control logic that meets requirements for advanced temperature control applications using PI-control (Proportional + Integral). As default the multi-stage control loop is configured for as single stage cooling (setpoint for the flow control loop controlling air flow) and single stage heating control (re-heat). Between the heating and cooling stages is a dead-zone where the heating and cooling outputs modulate to closed position providing energy savings in the building when the temperature reaches the setpoint. The heating and cooling deadzones can be separately set to provide asymmetrical control for increased energy savings.

Up to two (2) heating and up to two (2) cooling stages are available for more complex applications. The temperature control is operating in Occupied (comfort) / Unoccupied and Off modes. In unoccupied mode the temperature control is relaxed by increasing the heating and cooling deadzones. In the Off mode the temperature control is switched off (with frost protection active).

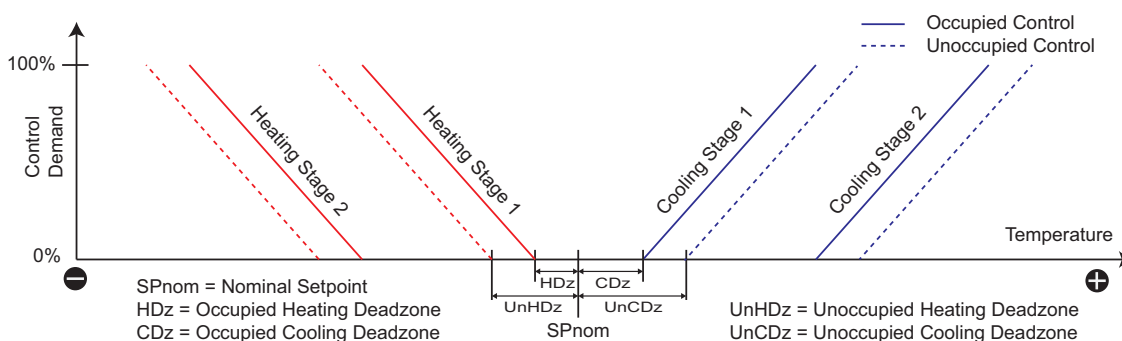

The multi-stage temperature control loop can be configured to control built-in temperature, Flow Input 1/voltage, Universal Input 2 Temperature/voltage, or network value (network temperature).

The loop controls to the Calculated Setpoint. The calculated setpoint uses the following formula:-

$$SP_{calc} = SP_{nom} + User_Adjustment + Reset_Function_Adjustment$$

NOTE: Network value can only be used in systems where the measurement changes slowly.

FROST PROTECTION (OFF MODE)

In the Night Off mode, the controller automatically monitors the control sensor for low temperature protection (Frost Setpoint). If temperature drops below the frost setpoint, the heating stages are switched on to 100% until temperature rises 2° above the Frost Setpoint.

Parameter	Description	Value Range / Enumerations
Main Loop Source	Sets the Control Source for the Multi-Stage Control Loop. Note: If UI2 mode is NTC, the control value is as measured temperature. If the UI mode is 0-10V, then 0..10V is scaled to measurement according to UI Input Min/Max scaling parameters 525-526.	0 = Network Value (Reg 538) 1 = Temperature (Built-In, Default) 2 = UI2 - NTC10 3 = Flow Input 1 - 0..10Vdc 4 = UI2 - 0..10Vdc
Main Loop Nominal Setpoint (SPnom)	Main Control Loop Nominal Setpoint Note: The control loop setpoint can be shifted by the high/low limit reset (cascade) control function indicated by limit icon.	0.0..212.0 (Default 21.0)
Main Setpoint Resolution	Main Setpoint Adjustment Resolution	0.1..10.0 (Default 0.1)
Min Adjustment	User Setpoint Adjustment Min Limit	-30.0..0.0 (Default -3.0)
Max Adjustment	User Setpoint Adjustment Max Limit	0.0..30.0 (Default 3.0)
Main Loop PB	Main Control Loop Proportional Band (for each stage)	1..500 (Default 5)
Main IA	Main Control Loop Integral Action Time (Set to 0 to disable)	0..3600s (Default 600s)
No of Heating Stages	Sets the number of heating stages.	0 = None 1 = 1-Stage (Default) 2 = 2-Stages 3 = 3-Stages
No of Cooling Stages	Sets the number of cooling stages.	0 = None 1 = 1-Stage (Default) 2 = 2-Stages 3 = 3-Stages
Occupied Heating Deadzone (HDz)	Occupied Mode Heating Deadzone	0.0..30.0 (Default 0.5)
Occupied Cooling Deadzone (CDz)	Occupied Mode Cooling Deadzone	0.0..30.0 (Default 0.5)
Unoccupied Heating Deadzone (UnHDz)	Unoccupied Mode Heating Deadzone	0.0..30.0 (Default 3.0)
Unoccupied Cooling Deadzone (UnCDz)	Unoccupied Mode Cooling Deadzone	0.0..30.0 (Default 3.0)
Frost Setpoint	Off Mode Frost Setpoint	0.0..60.0 (Default 10.0)

NOTE: If Change-Over function is activated, it can override the Heating Stage1 to operate as Cooling Stage1.

NOTE: Proportional Band is for each stage. E.g. if 3-stages of heating had been selected, and if the Proportional Band has been set as 5, then the Proportional Band accross 3-stages of heating is 15.

FLOW CONTROL LOOP (FOR PRESSURE INDEPENDENT VAV)

The controller has additional PI (Proportional + Integral) flow control loop where the control source can be configured to be the Flow Measurement (l/s, m3/h, cfm) connected to the Flow Input 1 (0-10Vdc flow signal).

The Flow Input 1 can measure either the flow (l/s, m3/h, cfm) from flow sensors, or differential pressure. If flow sensor, based on the flow sensor settings the 0-10V measurement is converted to the actual flow reading using 523: *Flow Scale Min*/ 524: *Flow Scale Max* parameters. If the differential pressure sensor - such as Senticon DPT50 - is used, the pressure is converted to the flow measurement using the K-value provided by the VAV box manufacturer.

In pressure independent VAV control the flow control loop flow setpoint is given by the temperature control loop depending how much demand there is in the room space for cooling (see diagram on the right). In this case the multi-stage control loop Cooling Stage 1 output demand (0-100%) is scaled to flow setpoint using the *Min Flow Setpoint* and *Max Flow Setpoint*. In other words the flow rate is controlled between these values.

The flow control loop setpoint can be set to a fixed value when the heating demand is present in the multi-stage control loop (0 = disabled).

NOTE: It is also possible to configure the Flow Control loop to operate in Fixed Setpoint mode. Set source to *Fixed Setpoint*, and configure *Fixed Setpoint* as the *Flow Control Setpoint Source*.

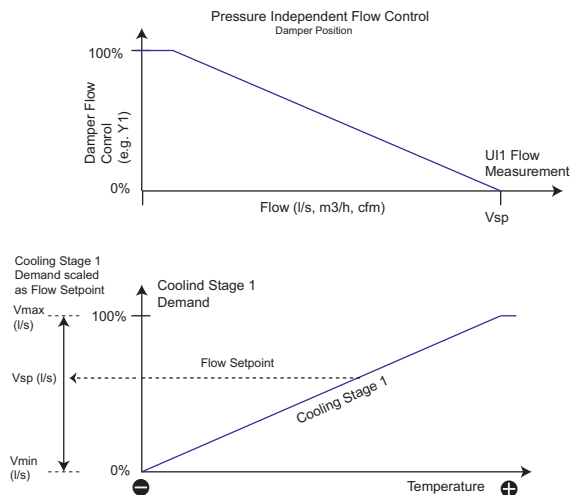

Parameter	Description	Value Range / Enumerations
Flow Control Setpoint Source	Select the Setpoint Source. Note: If Options 1..8 is selected the setpoint comes from selected source signal. The setpoint 0..100% is scaled based on the Min/Max Flow Setpoints. User adjustment is disabled.	0 = Fixed Setpoint 1 = Heating Stage 1 2 = Heating Stage 2 3 = Heating Stage 3 4 = Cooling Stage 1 (Default) 5 = Cooling Stage 2 6 = Cooling Stage 3 7 = Max Function 1 8 = Max Function 2
Min. Flow Setpoint	Minimum Flow Setpoint (Units in l/s, m3/h, cfm when <i>Control Source = Flow Input 1</i> . With pressure sensor unit configured using Param 515)	0..5,000 (Default 0)
Max. Flow Setpoint	Maximum Flow Setpoint (Units in l/s, m3/h, cfm when <i>Control Source = Flow Input 1</i> . With pressure sensor unit configured using Param 515)	0..5,000 (Default 150)
Heating Flow Setpoint	Flow Setpoint when Multi-Stage Loop Heating Demand is active (>0%)	0 = Disabled (Default) 0..5,000
Control Source	Sets the Source for the Flow Control. Note: The 0-10Vdc flow measurement is scaled to the flow value according to Flow Input Min/Max scaling parameters 523-524. Note: If UI2 mode is NTC, the control value is as measured by NTC10 sensor.	0 = Network Value (Reg 538) 1 = Temperature (Built-In) 2 = UI2 - NTC10 3 = Flow Input 1 - 0..10Vdc (Default) 4 = UI2 - 0..10Vdc
Flow Control PB	Flow Control Proportional Band	0..5000 (Default 50)
Flow Control IA	Flow Control Integral Action Time (Set to 0 to disable)	0..3600s (Default 100s)
FIXED SETPOINT MODE SETTINGS		
Fixed Setpoint	Flow Control Loop Fixed Setpoint	0..32000 (Default 21)
Setpoint Resolution	Setpoint Adjustment Resolution in Fixed Setpoint Mode	1..100 (default 1)
Min Adjustment	User Setpoint Adjustment Min Limit in Fixed Setpoint Mode	-300..0 (Default -30)
Max Adjustment	User Setpoint Adjustment Max Limit in Fixed Setpoint Mode	0..300 (Default 30)
FLOW AND DAMPER TEST PARAMETERS		
Damper Override	Overrides the damper output (Y output set to 7: Demand Flow) (From Fw1.11)	0 = No Override 1 = Override CLOSED 2 = Override OPEN
Flow Override	Overrides to Flow Control Loop setpoint to Minimum Flow or Maximum Flow Setpoint (from Fw1.11)	0 = No Override 1 = Min. Flow 2 = Max. Flow

BOOST FUNCTION

If the Boost Button has been activated on the Touchscreen, the controller output or mode can be boosted for the *Boost Time* by pressing the button. For more details refer to Boost Button section in the Touchscreen chapter.

MOVEMENT DETECTION AND CONTROL (OE OPTION)

The controllers can be fitted with an optional pyroelectric infrared motion sensor for the movement and occupancy detection. The sensor element is designed for optimal usability and reliability with low power consumption, better sensitivity and signal-to-noise ratio reducing the false detections. The diagram illustrates the detection area.

In Standard mode when the controller detects Occupancy it switches to Occupied Mode. The *PIR Delay Off Timer* (10..28,800 seconds) parameter sets the time that the status latches ON after detection of movement.

Once the timer has counted down the PIR status switches Off and the Controller Mode is switched to Unoccupied mode or Off mode depending on the configuration below.

NOTE: The PIR movement sensor has 30s warm-up time on reset.

NOTE: If the controller mode is overridden via the display or network, this mode is active until *PIR Delay Off Timer* resets.

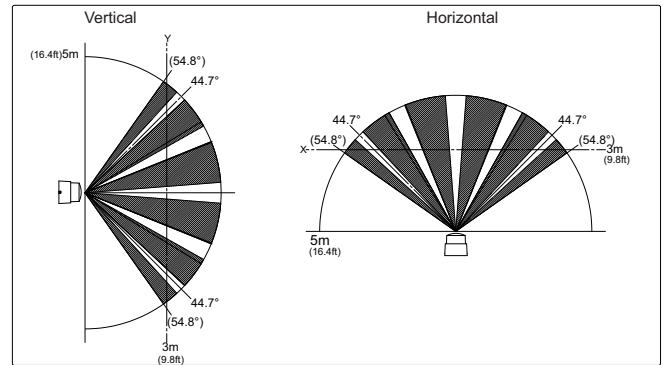

MULTI-TRIGGER MODE

The PIR mode can be changed to multi-trigger mode. In this mode during the *Trigger Period* the number of movement detections must reach the *PIR Trigger Count* amount for the controller to activate the Occupied. Mode. If within the *Trigger Period* the trigger count is not reached, it is reset to 0. After each movement detection, there is delay of 10 seconds until further movement is registered to the trigger count. This feature can be used, for example, prevent the system to switch on if a person enters temporarily to the room space.

Parameter	Description	Value Range / Enumerations
PIR Tigger Mode	Selects the MOfde of the PIR Sensor	0 - Standard (default) 1 - Multi-Trigger
PIR Trigger Count	Trigger Count in Multi-Trigger Mode	1..10 (default 600 secs)
Trigger Period	Trigger Period for monitoring Trigger Count	30..1,800 seconds (default 300 secs)
PIR Off Delay	Delay Off Timer for the PIR Movement/Occupancy sensor	10..28,800 seconds (default 600 secs)
Inactive PIR Control Mode	Activated Controller Mode when the PIR (OE-option) does not detect movement. If Option 0 = Unoccupied is selected, and the controller is in the OFF operating mode the PIR is disabled - no impact.	0 = Unoccupied Mode (Default) 1 = Off Mode
PIR Op. Mode Control	PIR influence on the operation mode. If set to Off, the PIR only shows the status on the network.	0 = On (Default) 1 = Off

Advanced Control Functions

Advanced control functions can be used to expand the pressure independent VAV or pressure dependent control with CO2/VOC air quality control or additional heating, cooling and fan control functions.

CO2 (CARBON DIOXIDE) CONTROL

QVR controllers have built-in CO2 measurement and control functionality. The CO2 measurement is typically used to boost the air flow in case of higher concentration. The QVR provides CO2 control using PI (Proportional + Integral) control logic.

With Proportional Control when the CO2 measurement increases above the CO2 Setpoint, the CO2 control demand (and control output) increases proportionally based on the Proportional Band (PB) setting - see image.

To use the VAV damper to increase fresh air flow in case of high CO2 and to control the temperature (cooling) the VAV Flow control setpoint is configured to use both Cooling1 Demand and CO2 Demand as setpoint.

For this set the 795 - Flow Control Setpoint Source to Max Function 2. Max Function 2 is as default configured to take the maximum of Cooling Demand and CO2 Demand.

The CO2 Setpoint Setback Parameter (764) allows the CO2 Setpoint to be increased in the Unoccupied mode for the amount set e.g. the CO2 setpoint can be changed from 750 in Occupied mode to 1250 in the Unoccupied mode.

The CO2 measurement can be displayed on the screen and the measurement is available via Modbus and BACnet communication network (please refer to Touchscreen and Modbus/BACnet Communications sections for further details).

The CO2 sensor provides Automatic Self Calibration logic keeping measurement accurate over the time. The Automatic calibration can be disabled and the sensor can be manually calibrated (see Calibration Settings).

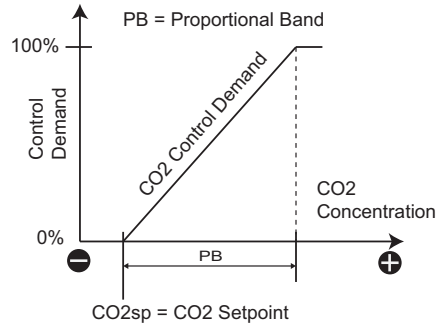

Parameter	Description	Value Range / Enumerations
CO2 Control Source	Sets the Source for the CO2 Control Note: If set to UI2, then 0..10V is scaled to measurement according to UI Input Min/Max scaling parameters 525-526.	0 = Network Value (Reg 539) 1 = Built-In CO2 (Default) 2 = UI2 - 0..10V
CO2 Setpoint	CO2 Control Setpoint	0..10,000 (Default 750)
CO2 PB	CO2 Control Proportional Band	1..10,000 (Default 500)
CO2 IA	CO2 Control Integral Action Time (Set to 0 to disable)	0..3600s (Default 0s)

VOC AIR QUALITY CONTROL (WITH RH-VOC OPTION)

The RH-VOC control option measures Volatile Organic Compounds with automatic humidity compensation providing relative indoor air quality index signal (see below diagram) between 0 to 500

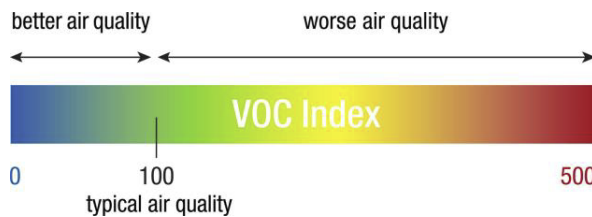

Measured air pollutants include harmful gases (acetone from paints and glues, toluene from furniture, mattresses and building products), other gases (ethanol from alcohol, perfumes and cleaners), odours (hydrogen sulfide and volatile sulfuric compounds from rotten food and farts; ammonia and amines from pet urine), smoke (benzene and nitrosamines from cigarette smoke).

With VOC PI (Proportional + Integral) control logic it is possible to control the air quality by e.g. increasing ventilation on high VOC concentration. The VOC control logic operates in Direct sequence ie. when the VOC Index increases the VOC Control Demand increases proportionally.

Parameter	Description	Value Range / Enumerations
VOC Setpoint	VOC Control Setpoint	0..500 (Default 100)
VOC PB	VOC Control Proportional Band	1..500 (Default 100)
VOC IA	VOC Control Integral Action Time (Set to 0 to disable)	0..3600s (Default 0s)

MAX FUNCTION

The controller has two max functions that have two inputs. Using the Max Functions it is possible to, for example, take maximum of cooling control and CO2 control to control VAV damper (Max 2 Default Settings).

Parameter	Description	Value Range / Enumerations
Max Function 1 Source 1	Sets the Source for Input 1 of Maximum Function 1 Default: Heating Stage 1	0 = Network Value (Reg 538)
Max Function 1 Source 2	Sets the Source for Input 2 of Maximum Function 1 Default: Cooling Stage 1	1 = Heating Stage 1 2 = Heating Stage 2 3 = Heating Stage 3
Max Function 2 Source 1	Sets the Source for Input 1 of Maximum Function 2 Default: Cooling Stage 1	4 = Cooling Stage 1 5 = Cooling Stage 2 6 = Cooling Stage 3
Max Function 2 Source 2	Sets the Source for Input 2 of Maximum Function 2 Default: CO2 Demand	7 = Auxiliary Demand 8 = CO2 Demand 9 = VOC Demand 10 = Humidity/DeHum Demand 11 = Max Function 1 12 = Max Function 2 13 = Fan Demand

EC FAN AND 3-SPEED FAN CONTROL

Fan control logic is used to control EC fans and 3-Speed fans and can be used as additional fan logic to control the VAV fan. Fan control logic can follow Continuous or Stepped control. In Continuous control when the source (e.g. heating and cooling demand) increases the fan speed increases linearly between speed settings.

When under automatic control if the input demand is less than the minimum level (*Min Fan Speed*) the output will be held at the minimum level. The only exception to this is when the *Fan Off Mode* is set to Off and the input demand is 0% in which case the output will be 0%

In stepped mode the Fan Speed is set in steps (for EC Fans or 3-Speed Fans) with 5% switching OFF hysteresis.

When the fan control source activates (increases above 0%) the Fan Speed is switched to 'Fan Speed 1' Level for adjustable delay time ('*Fan Startup Delay*') regardless of the *Min Fan Speed* setting. This allows EC Fans to start to run properly before resuming normal control.

If the *Fan Off Mode* setting is set to Off, the Fan output switches OFF after an adjustable '*Fan Off Delay*' Time.

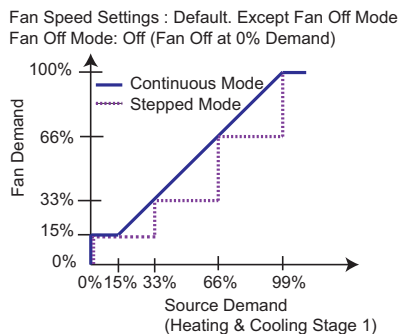
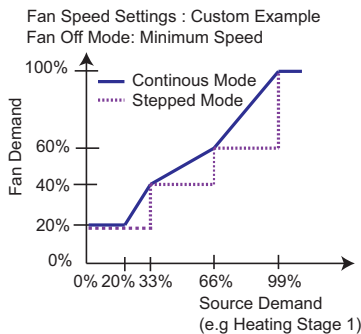
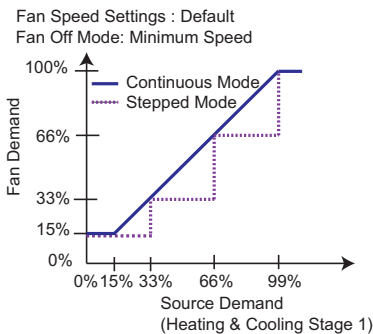

Parameter	Description	Value Range / Enumerations
Fan Control Source	Sets the Source Demand for the Fan Control Function.	0 = Network Value (Reg 538) 1 = Heating Stage 1 2 = Heating Stage 2 3 = Heating Stage 3 4 = Cooling Stage 1 5 = Cooling Stage 2 6 = Cooling Stage 3 7 = Flow Demand 8 = CO2 Demand 9 = VOC Demand 10 = Humidity/DeHum Demand 11 = Max Function 1 (Default) 12 = Max Function 2
Min Fan Speed	Sets the Minimum Fan Speed for EC Fans	0..100% (Default 15%)
Fan Speed 1	Sets the Fan Speed 1 for EC Fans (when source 33%)	0..100% (Default 33%)
Fan Speed 2	Sets the Fan Speed 2 for EC Fans (when source 66%)	0..100% (Default 66%)
Fan Speed 3	Sets the Fan Speed 3 for EC Fans (when source 99%)	0..100% (Default 100%)
Fan Mode	Sets the EC Fan Mode. Continuous Mode scales the fan demand based on the source and Fan Speed 1/2/3 settings. In Stepped mode the fan speed steps according to Fan Speed 1/2/3 settings. In stepped mode the Fan Speed switching hysteresis is 5%.	0 = Continuous Mode (Default) 1 = Stepped Mode
Fan Off Mode	Configures if the Fan is running at minimum level or is off when the fan control demand is at 0%.	0 = Off (Default) 1 = Minimum Speed
Fan Off Delay	Switch OFF delay when the source demand drops to 0 (and Fan Off Mode is set to Off)	0..600 seconds (Default 0)
Fan Startup Delay	Fan Startup when the source demand increases above 0%. During the delay the fan runs at Fan Speed 1 setting.	0..600 seconds (Default 10)
Fan Level Override	Current Fan Level that can be set from the touchscreen or network (last command prevails). Note: If Fan Levels = 0-1-A, options 2, 3 and 4 override to Automatic control. Note: If Fan Levels = 0-1-2-A, then Level 2 overrides to Speed 3. Both 3 and 4 override to Automatic control	0 = Off 1 = Level 1 2 = Level 2 3 = Level 3 4 = Automatic
Fan Levels	Sets the available Fan Override levels for the Touch button on the display and the Fan Network Override	0 = 0-1-A 1 = 0-1-2-A 2 = 0-1-2-3-A (Default)

MANUAL FAN SPEED CONTROL

The touchscreen fan speed manual override buttons set the Fan speed as per Fan Speed 1, 2 and 3 settings (see *Fan Speed Adjustment* section under Touchscreen chapter for details). In order for the controller to return back to automatic control the user needs to select Automatic mode.

The controller fan output level can also be override from the network by using the *Fan Override Level* parameter.

The available levels for manual and network control are set by the *Fan Levels* configuration parameter.

NOTE: In case of 0-1-2-A configuration if the user selects manual fan speed 2 from the touchscreen, the controller also uses Fan Speed 3 setting.

HUMIDITY CONTROL (WITH RH-OPTION)

The controller has a single stage humidity / dehumidity PI-control loop that calculates the loop demand based on the built-in or external humidity measurement. Set the *Humidity Mode* to *Humidify* for humidifying action and to *De-Humidify* for dehumidifying action.

Parameter	Description	Value Range / Enumerations
Humidity Source	Sets the Source for the Humidity Control. Note: If set to UI2, then 0..10V is scaled to measurement according to UI Input Min/Max scaling parameters 525-526.	0 = Network Value (Reg 538) 1 = Built-In Humidity (Default) 2 = UI2 - 0..10V
Humidity Setpoint	Humidity Control Loop Setpoint	0..100% (Default 50%)
Humidity PB	Humidity Control Proportional Band	1..100% (Default 20%)
Humidity IA	Humidity Control Integral Action Time (Set to 0 to disable)	0..3600s (Default 0s)

Humidity Mode	Humidity Loop Control Mode	0 = Humidify (Reverse) 1 = De-Humidify (Direct)
---------------	----------------------------	--

DEHUMIDIFICATION USING COOLING

In addition the controller has dehumidification function where the multi-stage temperature control Cooling Stage 2 is overridden to 100% when the dehumidification demand is 50% (and the Humidity Interlock function is enabled). The Cooling Stage 2 returns to automatic control after dehumidification demand drops to 0%. To control the switch on humidity and switch off humidity, it is recommended that the humidity PI-control loop is set to operate in P-mode (set Integral Action to 0 to disable it). Using this function it is possible to condition the supply air simultaneously with heat and cool (and dehumidify in the process, ref Mollier Diagram).

Parameter	Description	Value Range / Enumerations
Humidity Interlock	Enables Cooling Stage 2 Interlock on High Humidity (at 50% humidity loop demand)	0 = Disabled (Default) 1 = Enabled

NOTE: Register 425 can be used to indicate the current cooling mode status.

CONDENSATION CONTROL

CONDENSATION SENSOR INPUTS

In cooling systems when surface temperature drops reaching the dew point, this creates a condensation risk. The xVR controller have protection logic to minimise the condensation. This can be activated by enabling 'Digital Cooling Disable' on the Universal Input 2. In this mode the universal input operates as volt-free digital input. When the input closes the controller switches the multi-stage control loop Cooling Stage Demands to 0% until the volt-free input is off (open contact).

Alternative method is to use resistive condensation sensors where the resistance drops when condensation occurs, and resistance increases when the sensor is dry. To activate this function set the Universal Input 2 mode to 'Digital Cooling Disable'. When resistance drops approximately below 100kOhms the condensation risk is active and when the resistance increases above approx. 150kOhms, there is no condensation risk. In case of condensation risk the multi-stage Cooling Stage Outputs are set to 0%.

DEW POINT CONDENSATION CONTROL

If humidity sensor is fitted (-RH option), the dew point temperature can be calculated by the relative humidity and temperature. The xCR controllers have unique function, where the room temperature and humidity is used in calculation of the dew point temperature. This temperature is then compared to the pipe temperature (set UI2 to Dew Point mode) and when pipe temperature is dropping closer to the dew point temperature, the cooling outputs are **proportionally limited**, until the dew point danger has dissipated. The diagram on the right illustrates the maximum cooling output as a function of Dew Point temperature and Pipe temperature (calculated by *Dew Point Offset* - OSdp and *Dew Point Range* - Rdp parameters).

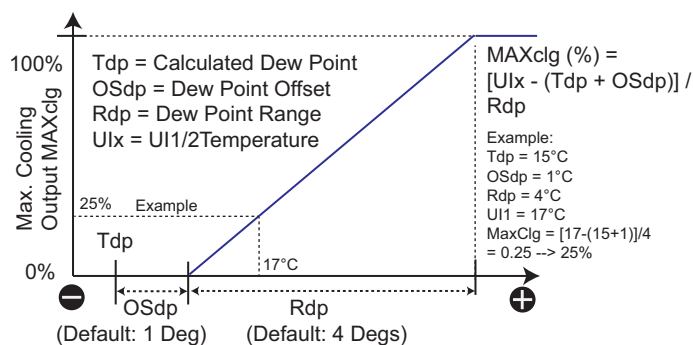

Alternatively by changing the *Dew Point Mode* parameter to **On/Off**, the cooling outputs are switched OFF at $Tdp + OSdp$ and return back to normal control at $Tdp + OSdp + Rdp$.

NOTE: The controller uses approximation method for the dew point temperature calculation. This only works when the relative humidity is more than 50% rH.

Flow / Pressure Input Configuration

The UI1 Input is configured as Flow Measurements from the VAV box. The measurement can be done either using Flow Sensors that give flow output (l/s, m3/h, cfm) or with differential pressure sensor (such as Senticon DPT50) and K-value from the VAV Box manufacturer for the flow conversion.

FLOW SENSOR CONFIGURATION

The input is configured to match the Flow Sensor output using the Flow Scale Min. and Flow Scale max. parameters as provided by the flow sensor. E.g. 0-10V = 0..150 l/s.

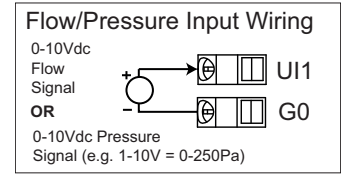

Parameter	Description	Value Range / Enumerations
Sensor Value Min.	Sets the scaling for Min. Measurement when UI1 @ 0V (0%)	-3200..3200 (Default -20)
Sensor Value Min.	Sets scaling for the Max. Measurement when UI1 @ 10V (100%)	-3200..3200 (Default 250)
K-Value Unit	Set to No Conversion - to read the flow measurement directly.	0 = No Conversion

PRESSURE SENSOR CONFIGURATION

To convert the pressure measurement (Pa) to the flow (l/s, m3/h, cfm), the K-value is required from the VAV box manufacturer. The controllers are typically connected to Senticon's DPT50 range pressure sensors. These give either -20..+250Pa or -20 to 500Pa pressure measurement range (0..10V = 0..250Pa or 0..10V = 0..500Pa).

Parameter	Description	Value Range / Enumerations	Senticon DPT50 -20..250Pa Pressure Sensor Settings
Sensor Value Min.	Sets the scaling for Min. Pressure Measurement when UI1 @ Sensor Voltage Min	-3200..3200 (Default -20)	-20
Sensor Value Min.	Sets scaling for the Max. Pressure Measurement when UI1 @ Sensor Voltage Max	-3200..3200 (Default 250)	250
Sensor Voltage Min.	Sets voltage @ Sensor Value Min.	0.0..10.0 (Default 0.0)	0.0
Sensor Voltage Max.	Sets voltage @ Sensor Value Max.	0.0..10.0 (Default 10.0)	10.0
K-Value Unit	Sets unit to K-value (given by VAV box manufacturer)	0 = No Conversion (flow sensor) 1 = l/s (Default) 2 = m3/h 3 = cfm	E.g. 1 = l/s
K-value	K-value to convert pressure to flow (set K-value Unit to match the value given by the VAV box manufacturer)	0..6550.0 (Default 7.2)	E.g 7.2 (for a typical DN100 VAV box)
Flow Cut-Off	Flow Cut-Off Value. Flow set to 0 if the measured flow is below this value	0.0..3200.0	E.g. 6 (l/s)

Universal Input 2 Configuration

Universal Input 2 can be configured to operate as NTC10 (resistive), Dew Point Sensor, Analogue (0..10V), Condensation Sensor (Resistive), Digital On/Off or Resistive kOhms (for leak detection sensors). Configure and wire inputs as required by the application operation using the diagram as guidance.

NTC10: Use this option to measure temperature using NTC10 temperature sensors. For control loops to use NTC10, select NTC10 in the control loop source parameters.

Dew Point Sensor: Uses the NTC10 Sensor for Dew Point Calculation Logic.

Digital Modes: Select as appropriate to override the controller operation modes.

Condensation Sensor Option (Option 5): Uses resistive condensation sensor.

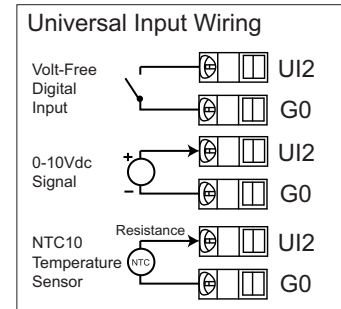

Parameter	Description	Value Range / Enumerations
UI Mode	<p>Sets the Universal Input 2 Mode.</p> <p>Default: Not Used</p> <p>Note: Options 6,7 and 8 override to selected controller mode on OFF to ON transition.</p> <p>Note: Option 9 overrides to Occupied Mode on ON transition and Unoccupied Mode on OFF transition.</p> <p>Note: Option 10 overrides to Occupied Mode on ON transition and Off Mode on OFF transition.</p> <p>Note: Option 12 activates boost function on state transition.</p>	<p>0 = Not Used</p> <p>1 = 0..10V (0..100%)</p> <p>2 = NTC10</p> <p>3 = Dew Point (NTC10)</p> <p>5 = Digital - Network</p> <p>5 = Digital - Disable Cooling / Resistive Condensation Sensor</p> <p>6 = Digital - Occupied</p> <p>7 = Digital - Unoccupied</p> <p>8 = Digital - Off</p> <p>9 = Digital - Unoccupied / Occupied</p> <p>10 = Digital - Off / Occupied</p> <p>11 = Resistive - kOhms</p> <p>12 = Boost</p>
UI Scale Min.	Sets the scaling for Min. Measurement when UI2 @ 0V (0%)	0..3000.0 (Default 0)
UI Scale Max.	Sets scaling for the Max. Measurement when UI2 @ 10V (100%)	0..3000.0 (Default 100.0)

UI2 Input Minimum and Maximum scaling parameters are used to scale 0..10V signal to the measurement. E.g. typical humidity transmitters scaled 0..100%rH measurement to 0..10V on their output. In this case set the *UI2 Scale Min.* parameter to 0 and *UI2 Scale Max.* parameter to 100.

In case of CO2 transmitter, these scale the 400..2,000ppm reading to 0..10V. In this case set the *UI2 Scale Min.* parameter to 400 and *UI2 Scale Max.* parameter to 2,000.

Analogue Output and Valve Control Options

0 - 10V OUTPUT CONFIGURATION AND SCALING

The Y1/Y2/Y3/Y4 0..10V outputs can be configured to control based on the options in the below table. In addition each output can be scaled between minimum and maximum limits. Reversing the limits is also possible which will reverse the output voltage (e.g. for situations where the 0..10V valve signal closes the valve instead of opening it).

These settings are typically used for the pressure dependent VAV damper control where the cooling demand is directly controlling the damper position.

NOTE: With pressure independent VAV control the minimum and maximum flow setpoints are set in the Flow Control loop settings. However using the 0-10V min/max limits it is possible further limit the maximum and minimum damper positions

NOTE: At Night Off mode the outputs switch to 0V (or 10V if reverse mode has been activated).

Parameter	Description	Value Range / Enumerations
Y1 Output Mode	Y1 Output Configuration Default: Heating Stage 1	0 = Network Value 1 = Heating Stage 1 2 = Heating Stage 2 3 = Heating Stage 3 4 = Cooling Stage 1 5 = Cooling Stage 2 6 = Cooling Stage 3 7 = Flow Demand 8 = CO2 Demand 9 = VOC Demand 10 = Humidity/DeHum Demand 11 = Max Function 1 12 = Max Function 2 13 = Fan Demand 15 = 6-Way Valve 15 = Reverse 6-Way Valve
Y2 Output Mode	Y2 Output Configuration Default: Flow Demand (flow control loop)	
Y3 Output Mode	Y3 Output Configuration Default: Fan Speed Control	
Y4 Output Mode	Y4 Output Configuration Default: CO2 Control Note: For Modus to override the output from the network set the mode to network. Note: For BACnet the output can be overridden using corresponding AV objects.	
Y1 Minimum	Y1 Output Minimum Level	0.0..100.0% (Default 0%)
Y1 Maximum	Y1 Output Maximum Level	0.0..100.0% (Default 100%)
Y2 Minimum	Y2 Output Minimum Level	0.0..100.0% (Default 0%)
Y2 Maximum	Y2 Output Maximum Level	0.0..100.0% (Default 100%)
Y3 Minimum	Y3 Output Minimum Level	0.0..100.0% (Default 0%)
Y3 Maximum	Y3 Output Maximum Level	0.0..100.0% (Default 100%)
Y4 Minimum	Y4 Output Minimum Level	0.0..100.0% (Default 0%)
Y4 Maximum	Y4 Output Maximum Level	0.0..100.0% (Default 100%)

6-WAY VALVE CONTROL

The 6-way valve option allows the controller to control 6-way valves that can be used for both heating and cooling control, simplifying heating/cooling coil structure. The principle of 6-way valve control is shown in the diagram. To activate the 6-way valve control the 0..10V output (Y1..Y4) is set to '6-way valve'. It is possible to modify the 6-way valve control parameters to suit the different 6-way valve manufacturers. The default settings are provided for Belimo 6-way valve.

Using the 'Reverse 6-Way Valve' option the Sequence 1 and Sequence 2 are swapped. This allows the controller to be configured to suit regardless of the 6-way valve piping.

The table below illustrates the switching parameters for the 6-way control.

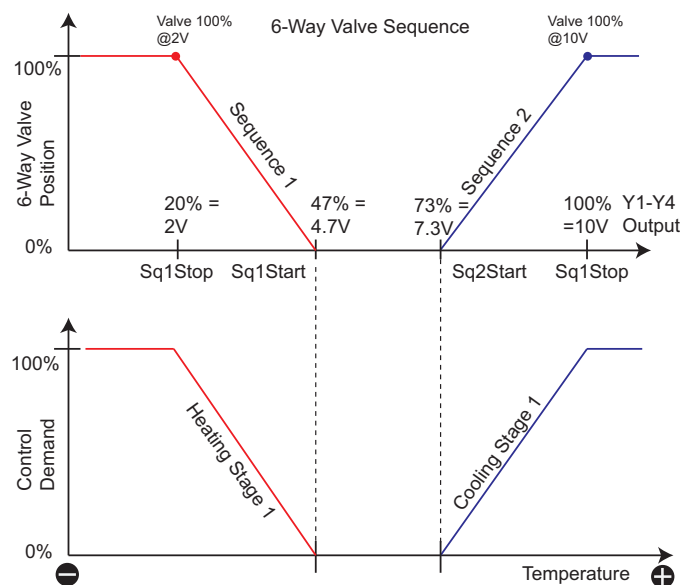

Parameter	Description	Value Range / Enumerations
Sequence 1 Start Value (Sq1Start)	6-Way Valve Sequence 1 Start Voltage. With setting '6-Way Valve' Main Loop Heating Stage 1 at 0% Demand.	0..100% (Default 47% = 4.7V)
Sequence 1 Stop Value (Sq1Stop)	6-Way Valve Sequence 1 Stop Voltage. With setting '6-Way Valve' Main Loop Heating Stage 1 at 100% Demand.	0..100% (Default 20% = 2V)
Sequence 2 Start Value (Sq2Start)	6-Way Valve Sequence 2 Start Voltage. With setting '6-Way Valve' Main Loop Cooling Stage 1 at 0% Demand.	0..100% (Default 73% = 7.3V)
Sequence 2 Stop Value (Sq2Stop)	6-Way Valve Sequence 2 Stop Voltage. With setting '6-Way Valve' Main Loop Cooling Stage 1 at 100% Demand.	0..100% (Default 100% = 10V)

Digital Output Control Options

RELAY CONTROL

The xCR10 controllers can have optional relay (RL-option). The relay output can be configured with the following options.

Parameter	Description	Value Range / Enumerations
Relay Output	<p>Relay Output Configuration</p> <p>By setting Relay = 1..12, the relay output is ON when the Demand is at 'DO On Value' and OFF when the Demand is 'DO Off Value' - See Digital Triac Output Control chapter below.</p> <p>By setting Relay = Fan Stage 1, the relay in ON when the Fan Demand Reaches Fan Stage 1. The relay is switched OFF when the Fan Demand is 5% less than Fan Stage 1 Demand.</p> <p>By Setting Relay = Occupied, the relay is ON when the controller is in Occupied Mode.</p> <p>By Setting Relay = Digital Input 1/2 (UI1/UI2), the relay follows the DI1/DI2 state (Set UI Mode to 4, 6, 7, 8, 9 or 10)</p>	<p>0 = None</p> <p>1 = Heating Stage 1</p> <p>2 = Heating Stage 2</p> <p>3 = Heating Stage 3</p> <p>4 = Cooling Stage 1</p> <p>5 = Cooling Stage 2</p> <p>6 = Cooling Stage 3</p> <p>7 = Flow Demand</p> <p>8 = CO2 Demand</p> <p>9 = VOC Demand</p> <p>10 = Humidity/DeHum Demand</p> <p>11 = Max Function 1</p> <p>12 = Max Function 2</p> <p>13 = Fan Stage 1</p> <p>14 = Occupied Mode</p> <p>15 = Digital Input 1</p> <p>16 = Digital Input 2</p>

NOTE: The relay output can be overridden from the network using the register 582 or using BV3 on BACnet.

Capacitive Touchscreen (TS Option)

The controllers can have optional full colour 240 x 320 pixel high resolution glass fronted display. The touchscreen indicates the controller status and measurements and provides the user interface. The touchscreen display elements can be tailored to the site specific requirements..

TOUCHSCREEN DISPLAY (SKIN COLOUR SELECTABLE)

Menu Icon - Press For Settings, Dim and Lock

Additional Icons Displayed after Pressing Menu

Action Bar with Buttons

TOP MENU BUTTONS

- Menu Icon (Access to settings, screen lock and dimming)
- Access to Configuration
- Button to Dim (no backlight)
- Button to Lock Screen (no access)

ACTION BAR BUTTONS

- Fan Speed Selection Button
- Mode Selection Button
- Boost (Timed) Button

STATUS BAR ICONS

- Menu Icon (Access to settings and dimming)
- Fan Speed Indication
- Occupied / Unoccupied / Night - Off
- Screen Locked
- Heating / Cooling
- Limit Function / Frost Mode
- Condensation

MAIN DISPLAY LOCATIONS

- Alarm Indication
- Descriptive Text Indication (Low / Normal / High)

Setpoint Adjustment view displayed

Text 'Set' indicating setpoint (press to change)

The touchscreen is divided to three different main elements; Status Bar, Measurement/Setpoint Display Locations and Buttons (accessible on the Action Bar on the bottom or via the Menu Icon on the top).

The Status Bar Indicates the controller status.

- Heating / Cooling Mode
- Limit Function / Frost Mode
- Unoccupied / Occupied / Off
- Fan Speed
- Lock Icon
- Condensation Icon
- Menu

The Controller has up to 5 different Measurement/Display Locations that can be tailored to show different measurements and setpoints. The display locations can also show alarm indications and additional information (energy, water usage) from the network. It is also possible to configure actual measurements to be in 'Descriptive Text' mode that makes the measurement information descriptive.

Each of the four display locations can be configured to show

- Main Temperature Loop, Flow Loop or Humidity Setpoints
- CO2, VOC, Temperature, or Humidity Measurement
- Flow Input 1 Measurement (l/s, m3/h, cfm)
- Universal Input 2 Measurements (0..10Vdc or NTC10)
- Network Signals (e.g. Energy, Water Consumption, Pressure, Light)

- Alarm Conditions of the Measurements (Green, Amber, Red)
- Descriptive Text instead of Measurement Value (Low / Normal / High)
- The description and units of each location can be customised
- Using Language Pack it is possible to change the text language
- The skin colour of the display can be changed according to the preference; White, Blue, Green, Grey and Black
- Brightness of the display can be adjusted
- Action Bar can have Boost button with an adjustable timer (overrides the controller output as configured), Fan speed adjustment option (A - 0 - 1 - 2 - 3), and/or Mode Button (selecting between Occupied / Unoccupied and Night Off modes)
- The display can be dimmed through the Menu button
- The display can be locked from unauthorised access through the Menu button
- Menu Button provides access to the Configuration Menu (network settings)

The screen skin colours can be chaged according to the site requirements (see below examples).

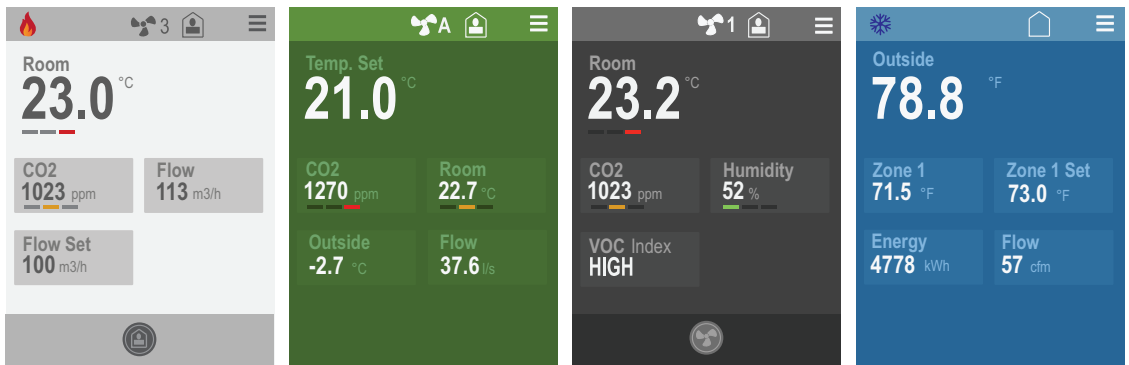

SETPOINT ADJUSTMENT

Any of the five display locations can be configured to show the main zone, the flow loop setpoint or humidity control loop setpoint. As default (from Fw1.14) by pressing the setpoint field, the setpoint slider display is showed allowing it to be altered by pressing plus and minus buttons, or byusing the slider. Pressing the plus or minus button continuously repeats the change with accelerating pace.

It is also possible to show the setpoint adjustment overlay on the main screen, by setting the parameter *611 Setpoint Slider Screen* : 0 = Disabled.

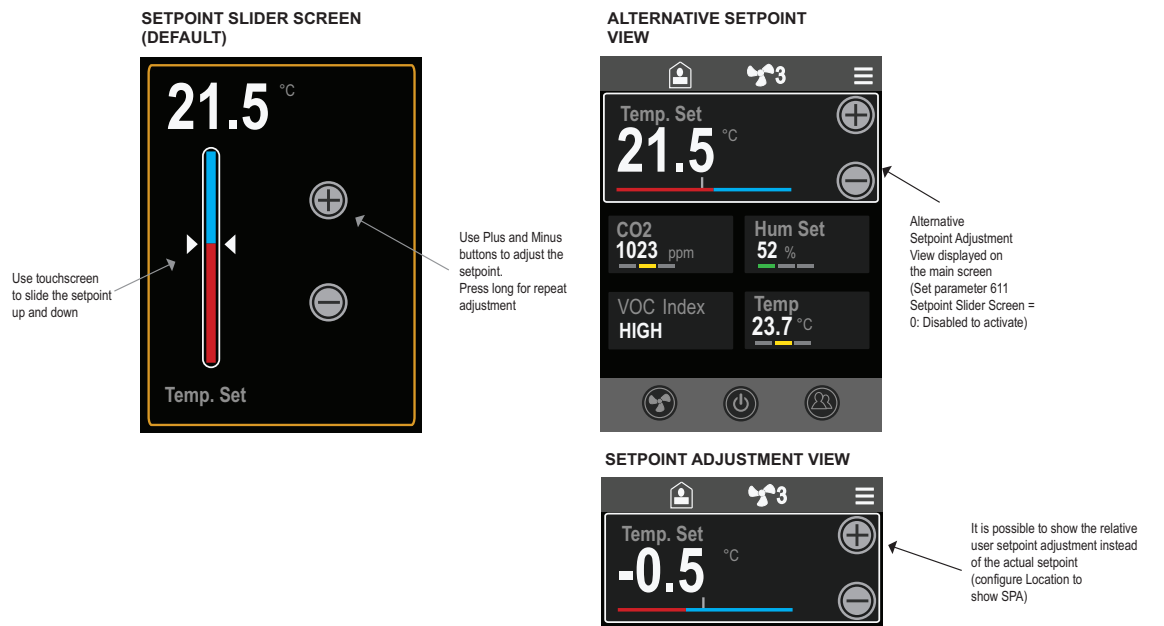

FAN SPEED ADJUSTMENT

By pressing the Fan button the fan speed adjustment options are displayed on the bottom Action Bar - select the required speed. The number of fan speeds is configurable. The current fan speed is displayed on the status bar on the top.

The Fan Speed button activation and number of fan speeds can be selected through the configuration parameters.

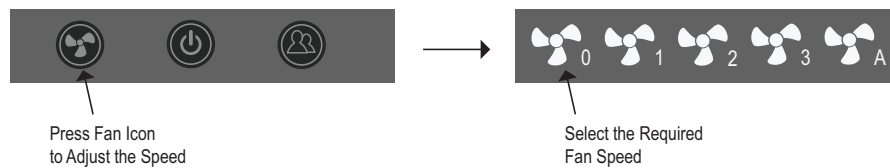

OPERATING MODE BUTTON

Pressing the Operating Mode Button the user can change the device operating mode. The operating mode button menu can be configured to show the following options for the user:

- Disabled; Button is not visible
- Occupied / Unoccupied Options Only
- Occupied / Unoccupied / Off Options (default)
- Occupied / Off Options Only

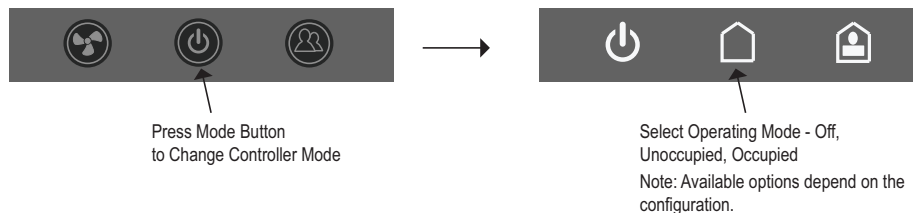

BOOST BUTTON (TIMED)

Pressing the Boost Button the selected device output or device mode (*Boost Target*) can be overridden for a timed period (*Boost Time*). Once selected the Button Colour Changes indicating active boost. The boost button has adjustable timer between 0..28,800 seconds. By setting boost time to 0 seconds, the Boost is permanent. The boost can be cancelled by pressing the boost button again.

The available Boost Targets are:-

- Heating Stage 1, 2 or 3 - target demand is overridden to 100% for the *Boost Time*
- Cooling Stage 1, 2 or 3 - target demand is overridden to 100% for the *Boost Time*
- Auxiliary Demand, CO2 Demand, VOC Demand, Humidity/DeHum Demand or Fan Demand - target demand is overridden to 100% for the *Boost Time*
- Occupancy Mode. Occupancy Boost overrides the controller mode to occupied period for the *Boost Time*. After the *Boost Time* the controller returns to the mode that was applied prior to the boost. If during the boost user or network overrides the controller mode, the boost is automatically cancelled.
- Flow Level - fixes the flow demand (flow control loop output) to the current value. Can be used e.g. with door switch to fix the damper actuator output when door is opened for a specified time.

The Boost Button, the Boost Target and the Boost Time are set through the configuration parameters.

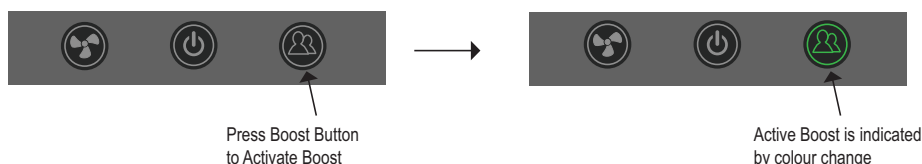

SCREEN LOCK

By selecting the Lock icon from the menu bar the screen is locked (buttons disabled, except menu and lock icons). If the Lock code is 0000, no code is required to lock and unlock the screen. By setting the lock code to any other value, the user needs to enter the code to lock and unlock the screen.

Note: The screen can also be locked and unlocked over the Modbus or BACnet network.

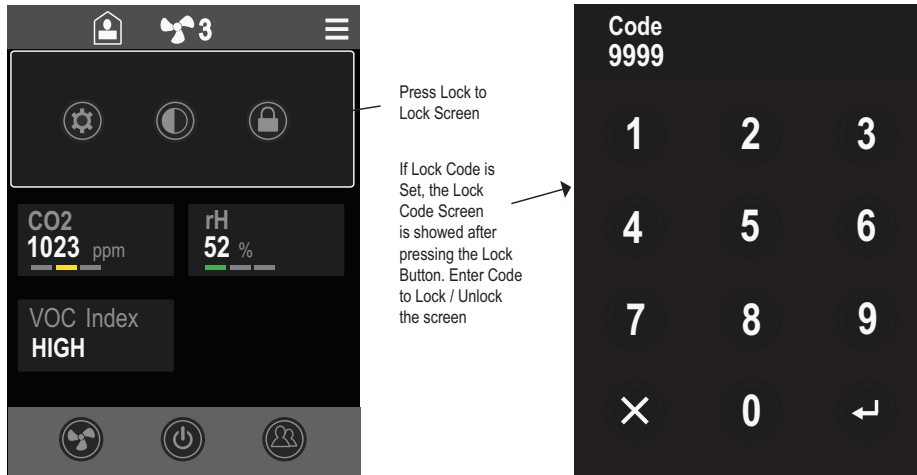

CONFIGURATION SCREEN

To access the Configuration Screen (for network settings), Press the Configuration Icon. If the configuration code is set (anything else than 0000), the Network and Configuration Settings Configuration Menu is displayed.

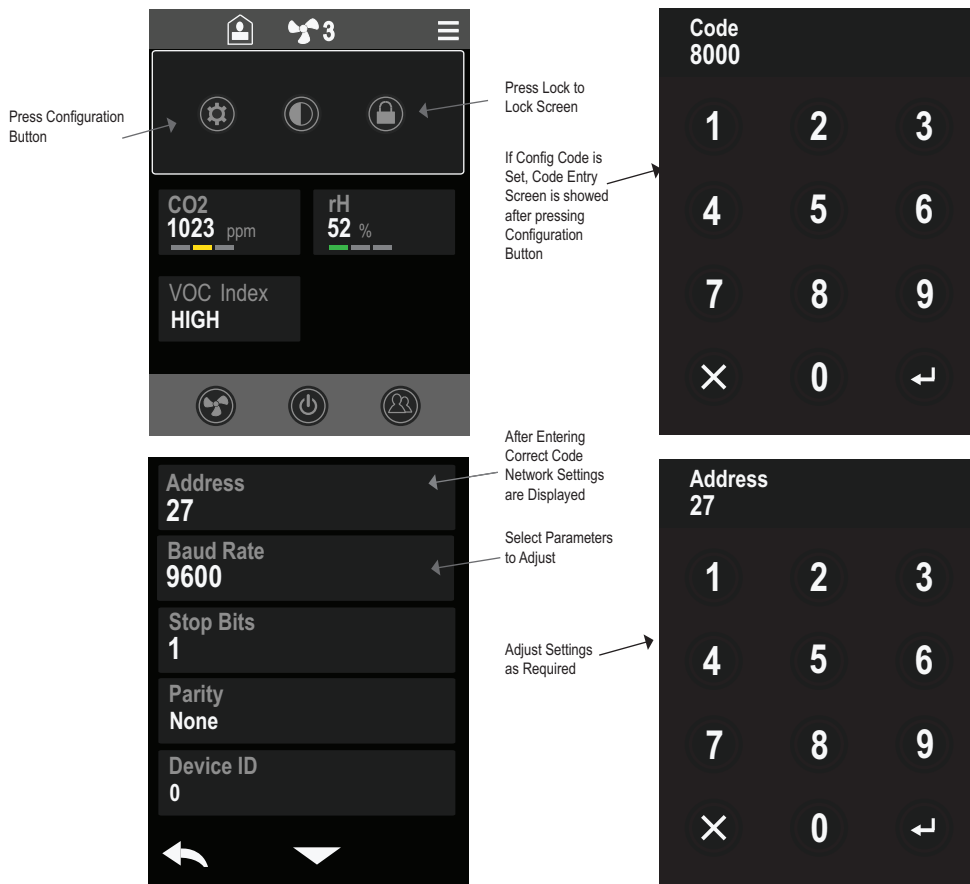

From pages 3 and 4 it is possible to override the damper position to fully open and close, and also override the flow control loop to control to Min and Max. flow positions for flow testing.

Note: Boost Flow Level function has higher priority i.e. if it is activate override only happens after the boost has been completed/cancelled.

In addition it is possible to configure the flow control loop settings.

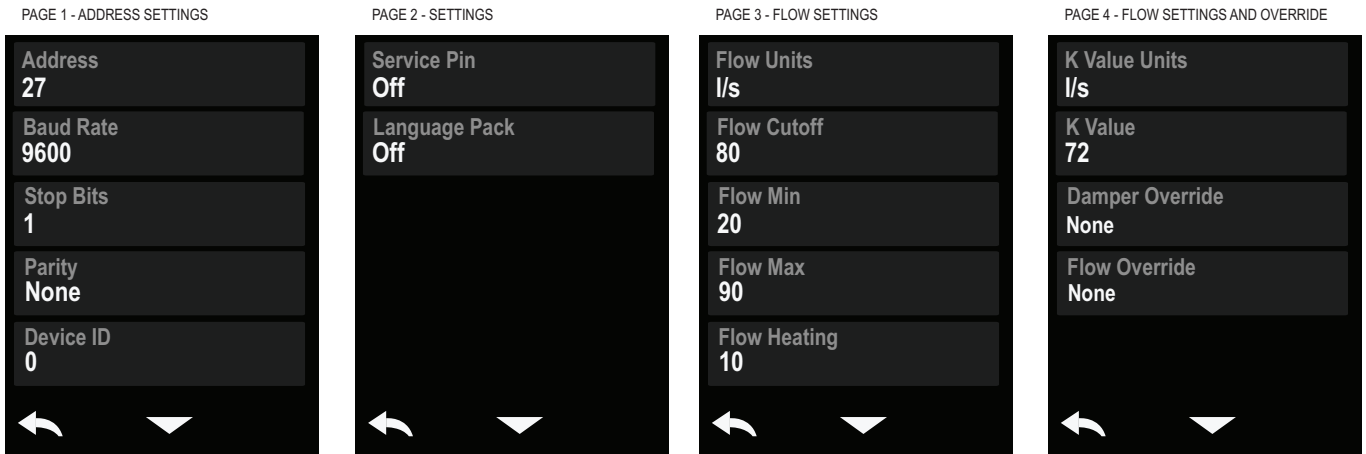

NOTE: Flow Cutoff, and K-value needs to be set x10 e.g for 7.2 set 72.

Wireless Interfaces

BLUETOOTH WIRELESS INTERFACE

With the -BLE option the devices are fitted with integrated Bluetooth Low Energy. The Bluetooth interface provides wireless connection point to SmartPhone app (iOS) to be able to interrogate and change the controller settings. Using the SmartView application the end users can change the device settings and see the current measurements. The SmartView application can be used as a complement to the display, or with non-display versions it can be used as the user interface.

NOTE: The SmartView application uses the device's display configuration to create the user view. If the device has no display, the display configuration settings can still be used to customise the user views on the App.

NOTE: With SmartConfig app you can change the devices Bluetooth name. This is also visible via the touchscreen through configuration menu (from Fw1.14).



LORAWAN® WIRELESS INTERFACE

With the -LRA option the devices are fitted with LoraWan® interface. The LoraWan® interface allows the devices to be connected to the LoraWan system wirelessly using Senticon's standard payload format.



The LoraWan® enabled devices will automatically connect to the network on power up. The connection attempts are staggered automatically based on the device serial number to ensure network performance on large systems. The devices will automatically send the device information (temperature, humidity, CO2, VOC, input and output levels and setpoints) on Senticon's Standard Payload format on scheduled intervals (1 to 60 minutes, default 10 minutes). If required, any other device parameter can also be read and set using Standard messaging format - please refer to Senticon LoraWan Payload Specification for further details.

LoraWan network settings can be adjusted for maximised wireless network performance. These settings include Transmission interval, Confirmed Message Interval, Number of Failed Uplink Messages, Burst Reconnect Mode and ADR disable.

Device Setup and Modbus/BACnet Communications

The devices are available with Modbus RTU or BACnet MS/TP communication for system integration. Please also note that the devices can be configured via Modbus or via BACnet MS/TP. Alternatively the devices can be configured locally using via PC Based Smart Config Tool or via iOS Smart Phone Application. Using any of these methods the device settings can be altered to suit the site requirements and the current device status can be interrogated.

Modbus and BACnet communication is carried out over RS485 serial network.

The Windows Smart Config Tool and iOS Smart Phone Application are connected to the device using Bluetooth dongle set (BLE-TOOLSET) that are plugged into the PC USB port and to the device (connection to device illustrated below). If the device is supplied with Built-In Bluetooth App interface (an option), then this can also be used for the tool communication connection

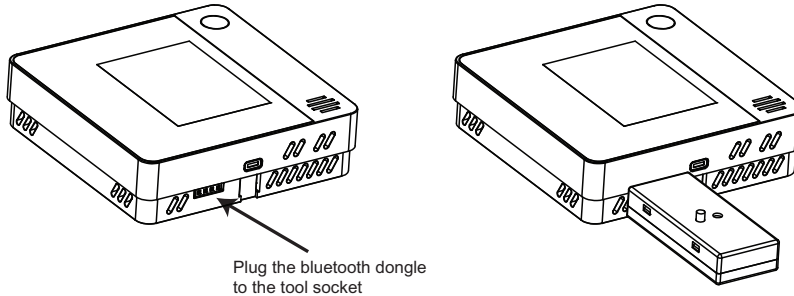

MODBUS / BACNET NETWORK SETUP

NOTE: Modbus RS485 or BACnet MS/TP versions are hardware specific models. It is not possible to change the communication protocol on the device. Please make sure to order the required model.

The devices can operate either as Modbus RTU RS485 slave device, or BACnet MS/TP Server. The device (slave/MAC) address and baud rate (limited) are set up using bit switches or through Windows Smart Configuration Tool / iOS Smart Phone App.

Bit switches 1-7 act as a binary decoder to set the (slave/MAC) address. Set these bit switches to OFF position if the address is configured by the software.

Bit switches 8 and 9 are used to set the baud rate. Set these bit switches to OFF position if the baud rate is configured by the software.

Bit switch EOL is used to activate 120 Ohm RS485 network End of Line termination (only used on the end of line devices).

NOTE: Once bit switches are changed the device will automatically carry out soft reset to activate the new settings.

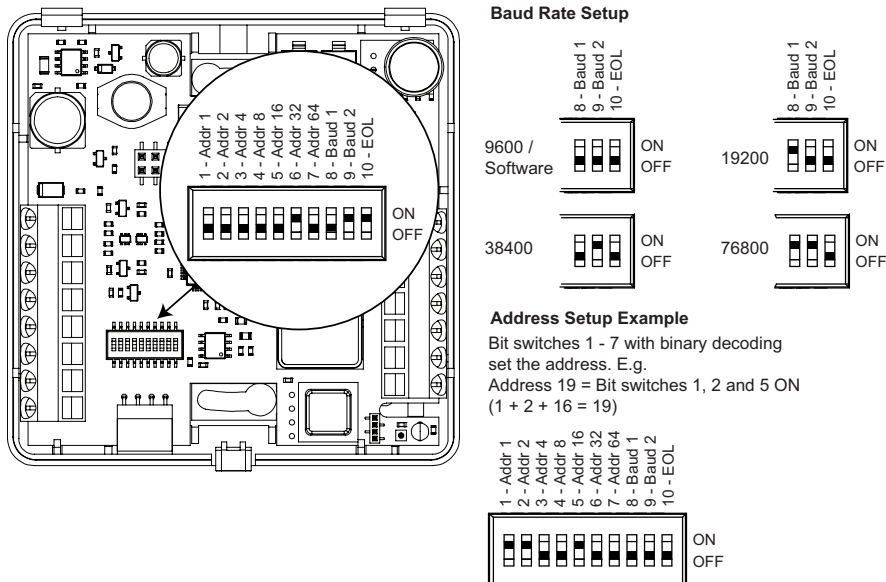

NOTE: Please note that Modbus register addresses start with 0 (0-based). If your Modbus master addresses start from one (1), then you will need to add one to the register values. If your Modbus master uses zero based addressing then the registers can be used as is.

NOTE: BACnet configuration parameter addresses are split to multiple instances of the Device Configuration object.

NOTE: Reg Field shows the Modbus register offset. The Reg field number is also the same with BACnet Device Configuration Objects.

LIVE DATA						
		MODBUS INPUT REGISTERS - FUNCTION CODE 05 MODBUS HOLDING REGISTER - FUNCTION CODES 03, (06), 16				
Parameter	Description	Reg	Type	Data Range (multiplier)	Value Range / Enumerations	R/W
INPUTS						
Temperature Sensor	Displays current temperature measurement reading (built-in sensor) Note: Value depends on the temperature unit °C/°F selection	400	int16	-400..2480 (x10)	-40.0..120.0°C / -40.0..258.0°F	R
Humidity Sensor	Displays current humidity measurement reading (With RH option)	401	uint16	0..1000 (x10)	0..100%RH	R
CO2 Sensor	Displays current measurement CO2 reading (QVR controllers)	402	uint16	0..10,000 (x1)	0..10,000ppm	R
VOC Sensor	Display current VOC (Volatile Organic Compound) Index Value	403	uint16	0..500 (x1)	0..500 index	R
Dew Point	Dew Point Temperature (requires RH option)	404	int16	-400..1200 (x10)	-40.0..120.0°C	R
Flow Input 1	Flow Sensor Input 1 Measurement (when pressure sensor, select unit from parameter 515: Flow Unit)	410	int16	0..5000.0 (x10)	0..5,000.0 (l/s, m3/h,cfm)	R
Differential Pressure	Calculated Differential Pressure when Flow Input 1 is used with the pressure sensor	419	int16	0..5000.0 (x10)	0..5,000.0	R
Universal Input 2	Universal Input 2 Measurement Note: Value depends on the temperature / mode selection	411	int16	-400..2480 (x10)	NTC Mode: -40..120° AI Mode: 0..100% = 0..10V	R
		DISCRETE INPUTS - FUNCTION CODE 02				
Digital Input 2	Digital Input 2 Status	201		0..1	0..1	R
PIR Status	PIR (OE Option) Status	202		0..1	0..1	R
Boost Status	Boost Button Status (TS Option) - Shows if Boost Button has been activated by the user.	204		0..1	0 = No Boost 1 = Boost	R
Screen Lock Status	Screen Lock Status	205		0..1	0 = Not Locked 1 = Locked	R
		MODBUS INPUT REGISTERS - FUNCTION CODE 05 MODBUS HOLDING REGISTER - FUNCTION CODES 03, (06), 16				
OUTPUTS						
Y1	Analogue Output 1 Value	412	uint16	0..1000 (x10)	0..100% = 0..10V	R
Y2	Analogue Output 2 Value	413	uint16	0..1000 (x10)	0..100% = 0..10V	R
Y3	Analogue Output 3 Value	415	uint16	0..1000 (x10)	0..100% = 0..10V	R
Y5	Analogue Output 5 Value	415	uint16	0..1000 (x10)	0..100% = 0..10V	R
Relay Status	Relay Output Status (RL Option)	203		0..1	0..1	R
DEMAND SIGNALS						
Calculated Multi-Stage Setpoint	Calculated Setpoint (Nominal Network Setpoint + User Adjustment) for Multi-Stage Control Loop Note: Write sets the Nominal Setpoint 701	420	int16	-32000..32000 (x10)	-3200.0..3200.0	R/W
Calculated Flow Setpoint	Calculated Flow Setpoint Note: When in Fixe Setpoint mode, the write sets the Setpoint 715	421	int16	0..32000 (x1)	0..32000	R/W
Heating Demand	Heating Stage Demand (Multi-Loop Heating Stage 1/2/3)	422	int16	0..1000 (x10)	0..100%	R
Cooling Demand	Cooling Stage Demand (Multi-Loop Cooling Stage 1/2/3)	423	int16	0..1000 (x10)	0..100%	R
Current Control Mode	Current Control Mode Status	424	int16	0..2 (x1)	0 = Occupied 1 = Unoccupied 2 = Night	R
Cooling Status	Main Loop Cooling Stage Override Status	425	int16	0..3 (x1)	0 = Normal Operation 1 = Digital Input Disable (Condensation) 2 = Dew Point Disable (Condensation) 3 = Dehumidify (Cooling Stage 2 Overridden ON)	R
Flow Demand	Flow Control Loop Demand	426	int16	0..1000 (x10)	0..100%	R

Fan Demand	Fan Loop Demand	427	int16	0..1000 (x10)	0..100%	R
CO2 Demand	CO2 Loop Demand	428	int16	0..1000 (x10)	0..100%	R
Humidity Demand	Humidity Control Loop Demand	429	int16	0..1000 (x10)	0..100%	R
VOC Demand	VOC Control Loop Demand	430	int16	0..1000 (x10)	0..100%	R

INPUT/OUTPUT SETTINGS						
Parameter	Description	Modbus Register / BACnet Property	MODBUS HOLDING REGISTER - FUNCTION CODES 03, 06, 16		Value Range / Enumerations	R/W
			Type	Data Range (multiplier)		
FLOW & PRESSURE SENSOR						
Sensor Value Min.	Sets scaling for the Max. Pressure Measurement when UI1 @ Sensor Voltage Max	523	sint16	-32000..32000 (x10)	-3200..3200 (Default -20)	R/W
Sensor Voltage Min.	Sets voltage @ Sensor Value Min.	525	sint16	-32000..32000 (x10)	-3200..3200 (Default 250)	R/W
Sensor Voltage Min.	Sets voltage @ Sensor Value Min.	516	uint16	0..100 (x10)	0..10.0 (Default 0)	R/W
Sensor Voltage Max.	Sets voltage @ Sensor Value Max.	517	uint16	0..100 (x10)	0..10.0 (Default 10.0)	R/W
K Value Unit	Sets unit to K-value (given by VAV box manufacturer) Set to 0: No conversion when a flow sensor is used	527	uint16	0..3 (x3)	0 = No Conversion 1 = l/s (Default) 2 = m3/h 3 = cfm	R/W
K Value	K-value to convert pressure to flow (set K-value Unit to match the value given by the manufacturer)	529	uint16	0..65500 (x10)	0..6550.0 (Default 7.2)	R/W
Flow Unit	Sets the calculated flow (510) unit when Pressure Sensor with k-value is used. Note: If 527 = No Conversion i.e. external flow sensor, this setting has no impact.	515	uint16	0..3 (x1)	0 = l/s (Default) 1 = m3/h 2 = cfm	R/W
Flow Cut-Off	Flow Cut-Off Value. Flow is set to 0 (param 410) if the measured flow is below this value	514	uint16	0..32000 (x10)	0..3200.0 (Default 7.2)	R/W
UNIVERSAL INPUT, TEMPERATURE						
UI2 Mode	Sets the Universal Input 2 Mode. Note: Options 6,7 and 8 override to selected controller mode on OFF to ON transition. Note: Option 9 overrides to Occupied Mode on ON transition and Unoccupied Mode on OFF transition. Note: Option 10 overrides to Occupied Mode on ON transition and Off Mode on OFF transition. Note: Option12 Boost activates the Boost function on Off to On transition. Use DI2 polarity to reverse if required.	521	unit16	0..12 (x1)	0 = Not Used (Not Used) 1 = 0..10V (0..100%) 2 = NTC10 3 = Dew Point (NTC10) 4 = Digital - Network 5 = Digital - Disable Cooling / Resistive Condensation Sensor 6 = Digital - Occupied 7 = Digital - Unoccupied 8 = Digital - Off 9 = Digital - Unoccupied / Occupied 10 = Digital - Off / Occupied 11 = Resistive - kOhms 12 = Boost	R/W
UI2 Scale Min.	Sets the scaling for Min. Measurement when UI2 @ 0V (0%)	525	unit16	0..30000 (x10)	0.0..3000.0 (Default 0)	R/W
UI2 Scale Max.	Sets scaling for the Max. Measurement when UI2 @ 10V (100%)	526	unit16	0..30000 (x10)	0.0..3000.0 (Default 100.0)	R/W
UI2 Voltage Min.	Sets Min. Clamp Voltage for UI2. Advanced Setting.	518	unit16	0..100 (x10)	0..10.0 (Default 0)	R/W
UI2 Voltage Max.	Sets Max. Clamp Voltage for UI2. Use only if the connected device upper range is more than 3000.	519	unit16	0..100 (x10)	0..10.0 (Default 10.0)	R/W
Temperature Units	Sets the temperature measurement and display to operate in Celcius or Fahrenheit. Note: To show Fahrenheit on display set the correct Unit setting on the display.	522	unit16	0..1 (x1)	0 = Celcius (Default) 1 = Fahrenheit	R/W

ANALOGUE OUTPUTS						
Y1 Mode	Y1 Output Configuration Default: Heating Stage 1	530	unit16	0..15 (x1)	0 = Network Value 1 = Heating Stage 1	R/W
Y2 Mode	Y2 Output Configuration Default: Flow Demand	531	unit16	0..15 (x1)	2 = Heating Stage 2 3 = Heating Stage 3	R/W
Y3 Mode	Y3 Output Configuration Default: Fan Speed Control	532	unit16	0..15 (x1)	4 = Cooling Stage 1 5 = Cooling Stage 2 6 = Cooling Stage 3	R/W
Y4 Mode	Y4 Output Configuration Default: CO2 Control Note: For Modus to override the output from the network set the mode to network. Note: For BACnet the output can be overridden using corresponding AV objects.	533	unit16	0..15 (x1)	7 = Flow Demand 8 = CO2 Demand 9 = VOC Demand 10 = Humidity Demand 11 = Max Function 1 12 = Max Function 2 13 = Fan Demand 15 = 6-Way Valve 15 = Reverse 6-Way Valve	R/W
Y1 Override	Analogue Output Y1 Override Value	534	unit16	0..1000 (x10)	0.0..100.0% (Default 0)	R/W
Y2 Override	Analogue Output Y2 Override Value	535	unit16	0..1000 (x10)	0.0..100.0% (Default 0)	R/W
Y3 Override	Analogue Output Y3 Override Value	536	unit16	0..1000 (x10)	0.0..100.0% (Default 0)	R/W
Y4 Override	Analogue Output Y4 Override Value	537	unit16	0..1000 (x10)	0.0..100.0% (Default 0)	R/W
Network Value 1	Network Value 1. Used for control loop external measurements and display functions.	538	int16	-9990..9990 (x10)	-999.0..999.0 (Default 0)	R/W
Network Value 2	Network Value 2 (for displaying network integer value e.g. energy measurements)	539	uint16	0..65535 (x1)	0..65535 (Default 0)	R/W
Y1 Minimum	Y1 Output Minimum Level	540	unit16	0..1000 (x10)	0.0..100.0% (Default 0%)	R/W
Y1 Maximum	Y1 Output Maximum Level	541	unit16	0..1000 (x10)	0.0..100.0% (Default 100%)	R/W
Y2 Minimum	Y2 Output Minimum Level	542	unit16	0..1000 (x10)	0.0..100.0% (Default 0%)	R/W
Y2 Maximum	Y2 Output Maximum Level	543	unit16	0..1000 (x10)	0.0..100.0% (Default 100%)	R/W
Y3 Minimum	Y3 Output Minimum Level	544	unit16	0..1000 (x10)	0.0..100.0% (Default 0%)	R/W
Y3 Maximum	Y3 Output Maximum Level	545	unit16	0..1000 (x10)	0.0..100.0% (Default 100%)	R/W
Y4 Minimum	Y4 Output Minimum Level	546	unit16	0..1000 (x10)	0.0..100.0% (Default 0%)	R/W
Y4 Maximum	Y4 Output Maximum Level	547	unit16	0..1000 (x10)	0.0..100.0% (Default 100%)	R/W
Sequence 1 Start Value (Sq1Start)	6-Way Valve Sequence 1 Start Voltage. With setting '6-Way Valve' Main Loop Heating Stage 1 at 0% Demand.	548	unit16	0..100 (x10)	0..100% (Default 57%)	R/W
Sequence 1 Stop Value (Sq1Stop)	6-Way Valve Sequence 1 Stop Voltage. With setting '6-Way Valve' Main Loop Heating Stage 1 at 100% Demand.	549	unit16	0..100 (x10)	0..100% (Default 20%)	R/W
Sequence 2 Start Value (Sq2Start)	6-Way Valve Sequence 2 Start Voltage. With setting '6-Way Valve' Main Loop Cooling Stage 1 at 0% Demand.	550	unit16	0..100 (x10)	0..100% (Default 73%)	R/W
Sequence 2 Stop Value (Sq2Stop)	6-Way Valve Sequence 2 Stop Voltage. With setting '6-Way Valve' Main Loop Cooling Stage 1 at 100% Demand.	551	unit16	0..100 (x10)	0..100% (Default 100%)	R/W

DIGITAL INPUTS						
DI2 Off Delay	Delay Off Timer for the Universal Input 2 in Digital Input Mode	561	uint16	0..28,800 (x1)	0..28,800 seconds (default 0 secs)	R/W
PIR Tigger Mode	Selects the Mode of the PIR Sensor	685	uint16	0..1 (x1)	0 - Standard (default) 1 - Multi-Trigger	R/W
PIR Trigger Count	Trigger Count in Multi-Trigger Mode	686	uint16	1..10 (x1)	1..10 (default 3)	R/W
Trigger Period	Trigger Period for monitoring Trigger Count	687	uint16	30..1,800 (x1)	30..1,800 seconds (default 300 secs)	R/W
PIR Off Delay	Delay Off Timer for the PIR Movement/Occupancy sensor	562	uint16	10..28,800 (x1)	10..28,800 seconds (default 600 secs)	R/W
DI2 Polarity	Digital Input Polarity	528	uint16	0..1 (x1)	0 = Normal (default) 1 = Reverse	R/W

DIGITAL OUTPUTS						
DO ON Value	The value at the Triac (or Relay) Output Switches ON	575	unit16	0..100 (x1)	0..100% (Default 50%)	

DO OFF Value	The value at the Triac (or Relay) Output Switches OFF	576	unit16	0..100 (x1)	0..100% (Default 0%)	R/W
Relay Override	Overrides the current output status of the relay permanently (overrides the local control, RL Option xCR10 Range Only).	582	uint16	0..2 (x1)	0 = No override (default) 1 = Override OFF 2 = Override ON	R/W

Parameter	Description	Modbus Register	MODBUS HOLDING REGISTER - FUNCTION CODES 03, 06, 16		Value Range / Enumerations	R/W
			Type	Data Range (multiplier)		
COMMISSIONING OVERRIDES (Modbus Versions Only)						
Y1 Commission Override	Y1 Commissioning Override Parameter (xCR10/xCR12)	690	uint16	0..3 (x1)	0 = Auto (Default) 1 = Manual Override 2 = 0% 3 = 100%	R/W
Y2 Commission Override	Y2 Commissioning Override Parameter (xCR10/xCR12)	691	uint16	0..3 (x1)		R/W
Y3 Commission Override	Y3 Commissioning Override Parameter (xCR10/xCR12)	692	uint16	0..3 (x1)		R/W
Y4 Commission Override	Y4 Commissioning Override Parameter (xCR10/xCR12)	693	uint16	0..3 (x1)		R/W
Y1 Override	Analogue Output Y1 Override Value (used when 690 = Manual)	534	unit16	0..1000 (x10)	0.0..100.0% (Default 0)	R/W
Y2 Override	Analogue Output Y2 Override Value (used when 691 = Manual)	535	unit16	0..1000 (x10)	0.0..100.0% (Default 0)	R/W
Y3 Override	Analogue Output Y3 Override Value (used when 692 = Manual)	536	unit16	0..1000 (x10)	0.0..100.0% (Default 0)	R/W
Y4 Override	Analogue Output Y4 Override Value (used when 693 = Manual)	537	unit16	0..1000 (x10)	0.0..100.0% (Default 0)	R/W

CALIBRATION SETTINGS						
Parameter	Description	Modbus Register / BACnet Property	MODBUS HOLDING REGISTER - FUNCTION CODES 03, 06, 16		Value Range / Enumerations	R/W
			Type	Data Range (multiplier)		
Temperature Offset	Built-In Temperature Single Point Sensor Calibration Offset	590	int16	-100..100 (x10)	-10.0..+10.0deg (Default 0)	R/W
Humidity Offset	Humidity Single Point Calibration Offset	591	int16	-100..100 (x10)	-10.0..+10.0%rH (Default 0)	R/W
CO2 Offset	CO2 Single Point Calibration Offset (adjusts CO2 reading the specified amount)	592	int16	-500..500 (x1)	-500..+500ppm (Default 0)	R/W
CO2 Auto-Calibration	Shows if the auto-calibration of the CO2 has been Activated	593	uint16	0..1	0 = Disabled 1 = Enabled (Default)	R/W
CO2 Calibration Value	Single Point Calibration Value for the CO2 Sensor. Note: Writing this value will reset the calibration settings of the sensor to the value set. Only recommended for advanced users.	594	uint16	350..3,000 (x1)	350..3,000ppm (Default 400)	R/W
Force CO2 Calibration	Forces CO2 Calibration to the CO2 Calibration Value. Use when CO2 level known e.g with calibration gas or outside air.	595	uint16	0..1	0 = None 1 = Force Calibration	R/W
CO2 Calibration Persist	Store CO2 Calibration Settings in the Permanent Memory	596	uint16	0..1	0 = None 1 = Save Data	R/W
Calibrate Flow	Calibrates the Flow Cut-Off (param 515) Value to the Current Measurement	597	uint16	0..1	0 = None 1 = Calibrate	R/W

TOUCHSCREEN AND GENERAL SETTINGS						
Parameter	Description	Modbus Register / BACnet Property	MODBUS HOLDING REGISTER - FUNCTION CODES 03, 06, 16		Value Range / Enumerations	R/W
			Type	Data Range (multiplier)		
GENERAL						
Display Colour	Sets the display colour (display skin).	600	uint16	0..4	0 = White 1 = Green 2 = Blue 3 = Grey (default) 54= Black	R/W
Display Brightness	Controls display brightness. By setting to Off, the display switches off after the timeout. Display wakes up when it is touched.	601	uint16	0..6	0 = Off 1 = 5% 2 = 10% 3 = 25% 4 = 50% (default) 5 = 75% 6 = 100%	R/W
Mode Icon Display	Activates Mode Icon display on the top status bar (Occupied / Unoccupied / Off).	602	uint16	0..1	0 = Disabled (default) 1 = Enabled	R/W
Heat/Cool Icon	Activates Heat/Cool icon on the top status bar.	603	uint16	0..1	0 = Disabled (default) 1 = Enabled	R/W
Enable Fan Display	Enables Fan Speed Display and/or Fan Speed Button.	604	uint16	0..3	0 = Disabled (default) 1 = Icon Only 2 = Touch	R/W
Enable Mode Button	Enables the Mode Button on the action bar.	605	uint16	0..3	0 = Disabled 1 = Occupied / Unoccupied 2 = Occupied / Unocc/ Off (default) 3 = Occupied / Off	R/W
Enable Boost Button	Enables Boost Button on the bottom action bar	606	uint16	0..1	0 = Disabled (default) 1 = Enabled	R/W
Lock Code	Screen Lock Code - 0000 = User requires no code to lock the screen	607	unit16	0..9,999 (x1)	0..9,999 (Default 0000)	R/W
Screen Lock Override	Overrides the Current State of the Screen Lock Note: If Override is on (i.e. set to 1 or 2), it is not possible to change the lock status from the screen.	608	unit16	0..2 (x1)	0 = No Override 1 = Unlock Screen 2 = Lock Screen	R/W
Config Code	Code to Enter Configuration Screen, Set to 0000 to bypass the requirement to enter the code.	609	unit16	0..9,999 (x1)	0..9,999 (Default 8000)	R/W
Setpoint Slider Screen	When enabled shows the Setpoint Slider Screen when adjusting setpoint. Disabled shows setpoint on the main screen.	611	unit16	0..1 (x1)	0 = Disabled 1 = Enabled (Default)	R/W

DISPLAY LOCATION 1 (PRIMARY DISPLAY LOCATION)						
Location 1 Display	Location 1 Display Source. Sets what is displayed in Location 1.	620	uint16	0..14	0 = None 1 = Network Decimal Value 2 = Network Integer Value 3 = Temperature 4 = Flow Input 1 5 = Universal Input 2 6 = Humidity 7 = CO2 8 = VOC Index 9 = Main Loop Setpoint (default) 10 = Flow Loop Setpoint 11 = Humidity Setpoint 12 = Heating Demand 13 = Cooling Demand 14 = Fan Demand	R/W
Location 1 Description	Location 1 Description. Sets description for Location 1.	621	uint16	0..24	0 = None 1 = Temperature 2 = Humidity 3 = CO2 4 = VOC 5 = Light Level 6 = Pressure 7 = Room 8 = Outside 9 = Fan 10 = Energy 11 = Water 12 = Electricity 13 = Heating 14 = Cooling 15 = Zone 1 16 = Zone 2 17 = Temp. Set (Default) 18 = Hum. Set 19 = CO2 Set 20 = Flow Set 21 = Room Set 22 = Zone 1 Set 23 = Zone 2 Set 24 = Flow	R/W
Location 1 Unit	Location 1 Unit. Sets unit for Location 1.	622	uint16	0..12	0 = None 1 = °C (Default) 2 = °F 3 = ppm 4 = Lux 5 = Pa 6 = kWh 7 = m3 8 = % 9 = index (air quality index) 10 = l/s 11 = m3/h 12 = cfm	R/W
Location 1 Alarm	Activates Location 1 Alarm Bar or Descriptive Text indication. Using 1=Bar activates Green, Amber, Red alarm icon indication underneath the current displayed parameter. Using 1=Text activates LOW, NORMAL, HIGH text indication instead of the measurement.	623	uint16	0..2	0 = Disabled (default) 1 = Bar 2 = Text	R/W
Location 1 Red Alarm Limit	Red Limit for Alarm 1 / High Limit for Descriptive Display	625	uint16	0..10,000 (x1)	0..10,000 (default 1250)	R/W
Location 1 Amber Alarm Limit	Amber Limit for Alarm 1 / Medium Limit for Descriptive Displays	625	uint16	0..10,000 (x1)	0..10,000 (default 750)	R/W
Location 1 Hysteresis	Hysteresis for Alarm 1 / Low Limit for Descriptive Displays	626	uint16	0..10,000 (x1)	0..10,000 (default 100)	R/W
Location 1 Read Only	Sets the location 1 to be Read Only or Read/Write. In Read Only mode touch functions are disabled for this location.	655	uint16	0..1	0 = Read-Write (default) 1 = Read Only	R/W

DISPLAY LOCATION 2						
Location 2 Display	Location 2 Display Source. Sets what is displayed in Location 2.	627	uint16	0..14	0 = None 1 = Network Decimal Value 2 = Network Integer Value 3 = Temperature (default) 4 = Flow Input 1 5 = Universal Input 2 6 = Humidity 7 = CO2 8 = VOC Index 9 = Main Loop Setpoint 10 = Flow Loop Setpoint 11 = Humidity Setpoint 12 = Heating Demand 13 = Cooling Demand 14 = Fan Demand	R/W
Location 2 Description	Location 2 Description	628	uint16	0..24	0 = None 1 = Temperature (Default) 2 = Humidity 3 = CO2 5 = VOC 5 = Light Level 6 = Pressure 7 = Room 8 = Outside 9 = Fan 10 = Energy 11 = Water 12 = Electricity 13 = Heating 14 = Cooling 15 = Zone 1 16 = Zone 2 17 = Temp. Set 18 = Hum. Set 19 = CO2 Set 20 = Flow Set 21 = Room Set 22 = Zone 1 Set 23 = Zone 2 Set 24 = Flow	R/W
Location 2 Unit	Location 2 Unit	629	uint16	0..12	0 = None 1 = °C (Default) 2 = °F 3 = ppm 4 = Lux 5 = Pa 6 = kWh 7 = m3 8 = % 9 = index (air quality index) 10 = l/s 11 = m3/h 12 = cfm	R/W
Location 2 Alarm	Activates Location 2 Alarm Bar or Descriptive Text indication. Using 1=Bar activates Green, Amber, Red alarm icon indication underneath the current displayed parameter. Using 2=Text activates LOW, NORMAL, HIGH text indication instead of the measurement.	630	uint16	0..2	0 = Disabled (default) 1 = Bar 2 = Text	R/W
Location 2 Red Alarm Limit	Red Limit for Alarm 2 / High Limit for Descriptive Display	631	uint16	0..10,000 (x1)	0..10,000 (default 30)	R/W
Location 2 Amber Alarm Limit	Amber Limit for Alarm 2 / Medium Limit for Descriptive Displays	632	uint16	0..10,000 (x1)	0..10,000 (default 25)	R/W
Location 2 Hysteresis	Hysteresis for Alarm 2 / Low Limit for Descriptive Displays	633	uint16	0..10,000 (x1)	0..10,000 (default 1)	R/W
Location 2 Read Only	Sets the location 2 to be Read Only or Read/Write. In Read Only mode touch functions are disabled for this location.	656	uint16	0..1	0 = Read-Write (default) 1 = Read Only	R/W

DISPLAY LOCATION 3						
Location 3 Display	Location 3 Display Source. Sets what is displayed in Location 3.	634	uint16	0..14	0 = None 1 = Network Decimal Value 2 = Network Integer Value 3 = Temperature 4 = Flow Input 1 5 = Universal Input 2 6 = Humidity 7 = CO2 (default) 8 = VOC Index 9 = Main Loop Setpoint 10 = Flow Loop Setpoint 11 = Humidity Setpoint 12 = Heating Demand 13 = Cooling Demand 14 = Fan Demand	R/W
Location 3 Description	Location 3 Description	635	uint16	0..24	0 = None 1 = Temperature 2 = Humidity 3 = CO2 (Default) 5 = VOC 5 = Light Level 6 = Pressure 7 = Room 8 = Outside 9 = Fan 10 = Energy 11 = Water 12 = Electricity 13 = Heating 14 = Cooling 15 = Zone 1 16 = Zone 2 17 = Temp. Set 18 = Hum. Set 19 = CO2 Set 20 = Flow Set 21 = Room Set 22 = Zone 1 Set 23 = Zone 2 Set 24 = Flow	R/W
Location 3 Unit	Location 3 Unit	636	uint16	0..12	0 = None 1 = °C 2 = °F 3 = ppm (default) 4 = Lux 5 = Pa 6 = kWh 7 = m3 8 = % 9 = index (air quality index) 10 = l/s 11 = m3/h 12 = cfm	R/W
Location 3 Alarm	Activates Location 3 Alarm Bar or Descriptive Text indication. Using 1=Bar activates Green, Amber, Red alarm icon indication underneath the current displayed parameter. Using 2=Text activates LOW, NORMAL, HIGH text indication instead of the measurement.	637	uint16	0..2	0 = Disabled 1 = Bar (default) 2 = Text	R/W
Location 3 Red Alarm Limit	Red Limit for Alarm 3 / High Limit for Descriptive Display	638	uint16	0..10,000 (x1)	0..10,000 (default 1250)	R/W
Location 3 Amber Alarm Limit	Amber Limit for Alarm 3 / Medium Limit for Descriptive Displays	639	uint16	0..10,000 (x1)	0..10,000 (default 750)	R/W
Location 3 Hysteresis	Hysteresis for Alarm 3 / Low Limit for Descriptive Displays	640	uint16	0..10,000 (x1)	0..10,000 (default 100)	R/W
Location 3 Read Only	Sets the location 3 to be Read Only or Read/Write. In Read Only mode touch functions are disabled for this location.	657	uint16	0..1	0 = Read-Write (default) 1 = Read Only	R/W

DISPLAY LOCATION 4						
Location 4 Display	Location 4 Display Source. Sets what is displayed in Location 4.	641	uint16	0..14	0 = None 1 = Network Decimal Value 2 = Network Integer Value 3 = Temperature 4 = Flow Input 1 5 = Universal Input 2 6 = Humidity (default) 7 = CO2 8 = VOC Index 9 = Main Loop Setpoint 10 = Flow Loop Setpoint 11 = Humidity Setpoint 12 = Heating Demand 13 = Cooling Demand 14 = Fan Demand	R/W
Location 4 Description	Location 4 Description	642	uint16	0..24	0 = None 1 = Temperature 2 = Humidity (Default) 3 = CO2 5 = VOC 5 = Light Level 6 = Pressure 7 = Room 8 = Outside 9 = Fan 10 = Energy 11 = Water 12 = Electricity 13 = Heating 14 = Cooling 15 = Zone 1 16 = Zone 2 17 = Temp. Set 18 = Hum. Set 19 = CO2 Set 20 = Flow Set 21 = Room Set 22 = Zone 1 Set 23 = Zone 2 Set 24 = Flow	R/W
Location 4 Unit	Location 4 Unit	643	uint16	0..12	0 = None 1 = °C 2 = °F 3 = ppm 4 = Lux 5 = Pa 6 = kWh 7 = m3 8 = % (Default) 9 = index (air quality index) 10 = l/s 11 = m3/h 12 = cfm	R/W
Location 4 Alarm	Activates Location 4 Alarm Bar or Descriptive Text indication. Using 1=Bar activates Green, Amber, Red alarm icon indication underneath the current displayed parameter. Using 2=Text activates LOW, NORMAL, HIGH text indication instead of the measurement.	644	uint16	0..2	0 = Disabled 1 = Bar (default) 2 = Text	R/W
Location 4 Red Alarm Limit	Red Limit for Alarm 4 / High Limit for Descriptive Display	645	uint16	0..10,000 (x1)	0..10,000 (default 80)	R/W
Location 4 Amber Alarm Limit	Amber Limit for Alarm 4 / Medium Limit for Descriptive Displays	646	uint16	0..10,000 (x1)	0..10,000 (default 60)	R/W
Location 4 Hysteresis	Hysteresis for Alarm 4 / Low Limit for Descriptive Displays	647	uint16	0..10,000 (x1)	0..10,000 (default 10)	R/W
Location 4 Read Only	Sets the location 4 to be Read Only or Read/Write. In Read Only mode touch functions are disabled for this location.	658	uint16	0..1	0 = Read-Write (default) 1 = Read Only	R/W

Parameter	Description	Modbus Register / BACnet Property	MODBUS HOLDING REGISTER - FUNCTION CODES 03, 06, 16		Value Range / Enumerations	R/W
			Type	Data Range (multiplier)		
DISPLAY LOCATION 5						
Location 5 Display	Location 5 Display Source. Sets what is displayed in Location 5.	648	uint16	0..14	0 = None 1 = Network Decimal Value 2 = Network Integer Value 3 = Temperature 4 = Flow Input 1 5 = Universal Input 2 6 = Humidity (default) 7 = CO2 8 = VOC Index 9 = Main Loop Setpoint 10 = Flow Loop Setpoint 11 = Humidity Setpoint 12 = Heating Demand 13 = Cooling Demand 14 = Fan Demand	R/W
Location 5 Description	Location 5 Description	649	uint16	0..25	0 = None 1 = Temperature 2 = Humidity (Default) 3 = CO2 4 = VOC 5 = Light Level 6 = Pressure 7 = Room 8 = Outside 9 = Fan 10 = Energy 11 = Water 12 = Electricity 13 = Heating 15 = Cooling 15 = Zone 1 16 = Zone 2 17 = Temp. Set 18 = Hum. Set 19 = CO2 Set 20 = Flow Set 21 = Room Set 22 = Zone 1 Set 23 = Zone 2 Set 24 = Flow	R/W
Location 5 Unit	Location 5 Unit	650	uint16	0..12	0 = None 1 = °C 2 = °F 3 = ppm 4 = Lux 5 = Pa 6 = kWh 7 = m3 8 = % (Default) 9 = index (air quality index) 10 = l/s 11 = m3/h 12 = cfm	R/W
Location 5 Alarm	Activates Location 5 Alarm Bar or Descriptive Text indication. Using 1=Bar activates Green, Amber, Red alarm icon indication underneath the current displayed parameter. Using 2=Text activates LOW, NORMAL, HIGH text indication instead of the measurement.	651	uint16	0..2	0 = Disabled 1 = Bar (default) 2 = Text	R/W
Location 5 Red Alarm Limit	Red Limit for Alarm 5 / High Limit for Descriptive Display	652	uint16	0..10,000 (x1)	0..10,000 (default 80)	R/W
Location 5 Amber Alarm Limit	Amber Limit for Alarm 5 / Medium Limit for Descriptive Displays	653	uint16	0..10,000 (x1)	0..10,000 (default 60)	R/W
Location 5 Hysteresis	Hysteresis for Alarm 5 / Low Limit for Descriptive Displays	654	uint16	0..10,000 (x1)	0..10,000 (default 10)	R/W

Location 5 Read Only	Sets the location 5 to be Read Only or Read/Write. In Read Only mode touch functions are disabled for this location.	659	uint16	0..1	0 = Read-Write (default) 1 = Read Only	R/W
----------------------	--	-----	--------	------	---	-----

CONTROL SETTINGS

Parameter	Description	Modbus Register / BACnet Property	MODBUS HOLDING REGISTER - FUNCTION CODES 03, 06, 16		Value Range / Enumerations	R/W
			Type	Data Range (multiplier)		

CONTROL MODES AND OVERRIDES

PIR Op. Mode Control	Built-in PIR influence on the operation mode. If set to Off, the built-in PIR only shows the status on the network and has no impact on the operating mode.	679	uint16	0..1	0 = On (Default) 1 = Off	R/W
Inactive PIR Control Mode	Activated Controller Mode when the PIR (OE-option) does not detect movement. If Option 0 = Unoccupied is selected, and the controller is in the OFF operating mode the PIR is disabled - no impact.	680	uint16	0..1	0 = Unoccupied Mode (Default) 1 = Off Mode	R/W
Override Control Mode	Override Current Control Mode (last transition applies e.g. if overridden from network the user can change through the display)	681	uint16	0..2 (x1)	0 = Occupied 1 = Unoccupied 2 = Night	R/W
Boost Time	Delay Off Timer for the Boost Button	682	uint16	0..28,800 (x1)	0..28,800 seconds 0 = Timer disabled, toggle functionality (default)	R/W
Boost Target	Sets the boost operation target. With options 1..11 the output is boosted to 100% for the Boost Time (Param 682). With option 12 - Occupancy - the controller mode is changed to the 'Occupied' mode for the Boost Time. With Option 13 the Flow Control loop flow level output is fixed to the current level until the boost has been deactivated.	683	uint16	0..13 (x1)	0 = None 1 = Heating Stage 1 2 = Heating Stage 2 3 = Heating Stage 3 4 = Cooling Stage 1 5 = Cooling Stage 2 6 = Cooling Stage 3 7 = Flow Demand 8 = CO2 Demand 9 = VOC Demand 10 = Humidity Demand 11 = Fan Demand 12 = Occupancy 13 = Flow Level	R/W
Reset User Adjustment	Resets the user setpoint adjustments (multi-stage, aux and humidity loops) when operating mode transitions away from the Occupied mode.	684	uint16	0..1	0 = Off (Default) 1 = On	R/W

MULTI-STAGE CONTROL LOOP

Main Loop Source	Sets the Control Source for the Multi-Stage Control Loop. Note: If UI2 mode is NTC, the control value is as measured. If the UI2 mode is 0-10V, then 0..10V is scaled to measurement according to UI2 Input Min/Max scaling parameters 525-526. Note: If 3 =Flow Input 1 mode is used, the actual control value is Flow Value/10.	700	uint16	0..4 (x1)	0 = Network Value (Reg 538) 1 = Temperature (Built-In, Default) 2 = UI2 - NTC10 3 = Flow Input 1 - 0..10Vdc 4 = UI2 - 0..10Vdc	R/W
Main Loop Nominal Setpoint (SPnom)	Main Control Loop Nominal Setpoint Note: The control loop setpoint can be shifted by the high/low limit (cascade) control function indicated by limit icon.	701	uint16	0..2120 (x10)	0.0..212.0, Default 21.0	R/W
Main Setpoint Resolution	Main Setpoint Adjustment Resolution	702	uint16	1..100 (x10)	0.1..10.0 (default 0.1)	R/W
Min Adjustment	User Setpoint Adjustment Min Limit	703	int16	-300..0 (x10)	-30.0..0.0 (Default -3.0)	R/W
Max Adjustment	User Setpoint Adjustment Max Limit	704	uint16	0..300 (x10)	0.0..30.0 (Default 3.0)	R/W
Main Loop PB	Main Control Loop Proportional Band (for each Stage)	705	uint16	1..500 (x1)	1..500 (Default 5)	R/W
Main IA	Main Control Loop Integral Action Time (Set to 0 to disable)	706	uint16	0..3600 (x1)	0..3600s (Default 600s) 0 = Disabled	R/W
No of Heating Stages	Sets the number of heating stages.	707	uint16	0..3 (x1)	0 = None 1 = 1-Stage (default)	R/W
No of Cooling Stages	Sets the number of cooling stages.	708	uint16	0..3 (x1)	2 = 2-Stages 3 = 3-Stages	R/W
Occ Heating Deadzone	Occupied Mode Heating Deadzone	709	uint16	0..300 (x10)	0.0..30.0 (Default 0.5)	R/W

Occ Cooling Deadzone	Occupied Mode Cooling Deadzone	710	uint16	0..300 (x10)	0.0..30.0 (Default 0.5)	R/W
Unocc Heating Deadzone	Unoccupied Mode Heating Deadzone	711	uint16	0..300 (x10)	0.0..30.0 (Default 3.0)	R/W
Unocc Cooling Deadzone	Unoccupied Mode Cooling Deadzone	712	uint16	0..300 (x10)	0.0..30.0 (Default 3.0)	R/W
Frost Setpoint	Off Mode Frost Setpoint	713	uint16	0..600 (x10)	0.0..60.0 (Default 10.0)	R/W

FLOW CONTROL LOOP						
Flow Control Setpoint Source	Select the Setpoint Source. Note: Option 0 sets the loop setpoint to (Fixed) Flow Setpoint. Note: If Options 1..8 is selected the setpoint comes from selected setpoint signal. The setpoint 0..100% is scaled based on the Min/Max Flow Setpoints. User adjustment is disabled.	795	uint16	0..1 (x1)	0 = Fixed Setpoint 1 = Heating Stage 1 2 = Heating Stage 2 3 = Heating Stage 3 4 = Cooling Stage 1 (Default) 5 = Cooling Stage 2 6 = Cooling Stage 3 7 = Max Function 1 8 = Max Function 2	R/W
Min Flow Setpoint	Minimum Flow Setpoint (Units in l/s, m3/h, cfm when <i>Control Source = Flow Input 1</i> . With pressure sensor unit configured using Param 515)	796	unit16	0.5000 (x1)	0..5000 (Default 0.0)	R/W
Max. Flow Setpoint	Maximum Flow Setpoint (Units in l/s, m3/h, cfm when <i>Control Source = Flow Input 1</i> . With pressure sensor unit configured using Param 515)	797	unit16	0..5000 (x1)	0..5000 (Default 150)	R/W
Heating Flow Setpoint	Flow Setpoint when Multi-Stage Loop Heating Demand is active (>0%) (Units in l/s, m3/h, cfm when <i>Control Source = Flow Input 1</i> . With pressure sensor unit configured using Param 515)	798	unit16	0..5000 (x1)	0 = Disabled (Default) 0.. 5000	R/W
Control Source	Sets the Source for the Flow Control Loop. Note: If UI2 mode is NTC, the control value is as measured. If the UI2 mode is 0-10V, then 0..10V is scaled to measurement according to UI2 Input Min/Max scaling parameters 525-526.	715	uint16	0..4 (x1)	0 = Network Value (Reg 538) 1 = Temperature (Built-In) 2 = UI2 - NTC10 3 = Flow Input 1 - 0..10Vdc (Default) 4 = UI2 - 0..10Vdc	R/W
Flow PB	Flow Control Proportional Band	719	uint16	1..500 (x1)	1..5000 (Default 100)	R/W
Flow IA	Flow Control Integral Action Time (Set to 0 to disable)	720	uint16	0..3600 (x1)	0..3600s (Default 100s) 0 = Disabled	R/W
Damper Override	Overrides the damper output (Y output set to 7: Demand Flow) (From Fw1.11)	799	uint16	0..3 (x1)	0 = No Override 1 = Override CLOSED 2 = Override OPEN	R/W
Flow Override	Overrides to Flow Control Loop setpoint to Minimum Flow or Maximum Flow Setpoint (from Fw1.11)	795	uint16	0..3 (x1)	0 = No Override 1 = Min. Flow 2 = Max. Flow	R/W
FIXED SETPOINT MODE						
Flow Setpoint	Flow Control Loop Setpoint	715	uint16	0..32000 (x1)	0..32000 (Default 0)	R/W
Setpoint Resolution	Flow Setpoint Adjustment Resolution in Fixed Setpoint Mode	716	uint16	1..100 (x1)	1..100 (default 1)	R/W
Min Adjustment	User Setpoint Adjustment Min Limit in Fixed Setpoint Mode	717	int16	-300..0 (x1)	-300..0 (Default -30)	R/W
Max Adjustment	User Setpoint Adjustment Max Limit in Fixed Setpoint Mode	718	uint16	0..300 (x1)	0..300 (Default 30)	R/W

MAX FUNCTION						
Max Function 1 Source 1	Sets the Souce for Input 1 of Maximum Function 1 Default: Heating Stage 1	732	uint16	0..13 (x1)	0 = Network Value (Reg 538)	R/W
Max Function 1 Source 2	Sets the Souce for Input 2 of Maximum Function 1 Default: Cooling Stage 1	733	uint16	0..13 (x1)	1 = Heating Stage 1 2 = Heating Stage 2 3 = Heating Stage 3	R/W
Max Function 2 Source 1	Sets the Souce for Input 1 of Maximum Function 2 Default: Cooling Stage 1	734	uint16	0..13 (x1)	4 = Cooling Stage 1 5 = Cooling Stage 2	R/W
Max Function 2 Source 2	Sets the Souce for Input 2 of Maximum Function 2 Default: CO2 Demand	735	uint16	0..13 (x1)	6 = Cooling Stage 3 7 = Flow Demand 8 = CO2 Demand 9 = VOC Demand 10 = Humidity Demand 11 = Max Function 1 12 = Max Function 2 13 = Fan Demand	R/W

FAN CONTROL						
Fan Control Source	Sets the Temperature Source for the Fan Control Function.	740	uint16	0..12 (x1)	0 = Network Value (Reg 538) 1 = Heating Stage 1 2 = Heating Stage 2 3 = Heating Stage 3 4 = Cooling Stage 1 5 = Cooling Stage 2 6 = Cooling Stage 3 7 = Flow Demand 8 = CO2 Demand 9 = VOC Demand 10 = Humidity Demand 11 = Max Function 1 (Default) 12 = Max Function 2	R/W
Min Fan Speed	Sets the Minimum Fan Speed for EC Fans	741	uint16	0..100 (x1)	0..100% (Default 15%)	R/W
Fan Speed 1	Sets the Fan Speed 1 for EC Fans (when source 33%)	742	uint16	0..100 (x1)	0..100% (Default 33%)	R/W
Fan Speed 2	Sets the Fan Speed 2 for EC Fans (when source 66%)	743	uint16	0..100 (x1)	0..100% (Default 66%)	R/W
Fan Speed 3	Sets the Fan Speed 3 for EC Fans (when source 99%)	745	uint16	0..100 (x1)	0..100% (Default 100%)	R/W
Fan Mode	Sets the EC Fan Mode. Continuous Mode scales the fan demand based on the source and Fan Speed 1/2/3 settings. In Stepped mode the fan speed steps according to Fan Speed 1/2/3 settings.	745	uint16	0..1 (x1)	0 = Continuous Mode (Default) 1 = Stepped Mode	R/W
Fan Off Mode	Configures if the Fan is running at minimum level or is off when the fan control demand is at 0%.	746	uint16	0..1 (x1)	0 = Off (Default) 1 = Minimum Speed	R/W
Fan Off Delay	Switch OFF delay when the source demand drops to 0 (and Fan Off Mode is set to Off)	747	uint16	0..600 (x1)	0..600 seconds (Default 0)	R/W
Fan Start-Up Delay	Fan Start-Up when the source demand increases above 0%. During the delay the fan runs at Fan Speed 1 setting.	748	uint16	0..600 (x1)	0..600 seconds (Default 10)	R/W
Fan Level Override	Current Fan Level that can be set from the touchscreen or network (last command prevails). Note: If Fan Levels = 0-1-A, options 2, 3 and 4 override to Automatic control. Note: If Fan Levels = 0-1-2-A, then Level 2 overrides to Speed 3. Both 3 and 4 override to Automatic control	749	uint16	0..4	0.4 (Off / Speed1-2-3 / Auto)	R/W
Fan Levels	Set the Fan Levels for the network override and for the touch button operation	750	uint16	0..2	0 = 0-1-A 1 = 0-1-2-A 2 = 0-1-2-3-A (Default)	R/W
AIR QUALITY CONTROL						
CO2 Control Source	Sets the Source for the CO2 Control Note: If set to UI2, then 0..10V is scaled to measurement according to UI2 Input Min/Max scaling parameters 525-526.	760	uint16	0..2 (x1)	0 = Network Value (Reg 539) 1 = Built-In CO2 (Default) 2 = UI2 - 0..10V	R/W
CO2 Setpoint	CO2 Control Setpoint	761	uint16	0..10000 (x1)	0..10,000 (Default 750)	R/W
CO2 PB	CO2 Control Proportional Band	762	uint16	1..10000 (x1)	1..10,000 (Default 500)	R/W
CO2 IA	CO2 Control Integral Action Time (Set to 0 to disable)	763	uint16	0..3600 (x1)	0..3600s (Default 0s)	R/W
CO2 Setpoint Setback	CO2 Control Setpoint SetBack in Unoccupied mode	764	uint16	0..2000 (x1)	0..2,000 (Default 0)	R/W
VOC Setpoint	VOC Control Setpoint	770	uint16	0..500 (x1)	0..500 (Default 100)	R/W
VOC PB	VOC Control Proportional Band	771	uint16	1..500 (x1)	1..500 (Default 100)	R/W
VOC IA	VOC Control Integral Action Time (Set to 0 to disable)	772	uint16	0..3600 (x1)	0..3600s (Default 0s)	R/W

HUMIDITY CONTROL						
Humidity Source	Sets the Source for the Humidity Control. Note: If set to UI2, then 0..10V is scaled to measurement according to UI2 Input Min/Max scaling parameters 525-526.	780	uint16	0..2 (x1)	0 = Network Value (Reg 539) 1 = Built-In Humidity (Default) 2 = UI2 - 0..10V	R/W
Humidity Setpoint	Humidity Control Loop Setpoint	781	uint16	0..100 (x1)	0..100% (Default 50%)	R/W
Humidity PB	Humidity Control Proportional Band	782	uint16	1..100 (x1)	1..100% (Default 20)	R/W
Humidity IA	Humidity Control Integral Action Time (Set to 0 to disable)	783	uint16	0..3600 (x1)	0..3600s (Default 0s)	R/W
Humidity Mode	Humidity Loop Control Mode Default: Humidify (Reverse)	784	uint16	0..1 (x1)	0 = Humidify (Reverse) 1 = De-Humidify (Direct)	R/W

Humidity Interlock	Enables Cooling Stage 2 Interlock on High Humidity	785	uint16	0..1 (x1)	0 = Disabled (Default) 1 = Enabled	R/W
Dew Point Mode	Dew Point Mode Selection	787	uint16	0..1 (x1)	0 = On-Off 1 = Proportional (Default)	R/W
Dew Point Range	Dew Point calculation range where the Dew Point based cooling max. position calculates linearly from 100% to 0%	786	uint16	0..10 (x1)	0..10 Degrees (Default 4)	R/W
Dew Point Offset	Dew Point Offset (from the calculated Dew Point) where the Dew Point based calculated max. position is 0%	788	uint16	0..5 (x10)	0..5.0 Degrees (Default 1.0)	R/W

SYSTEM AND COMMUNICATION SETTINGS						
Parameter	Description	Modbus Register / BACnet Property	MODBUS HOLDING REGISTER - FUNCTION CODES 03, 06, 16		Value Range / Enumerations	R/W
			Type	Data Range (multiplier)		
Address	Modbus Address BACnet MAC Address	800	uint16	1..247 (x1) 1..127 (x1)	Modbus: 1..247 BACnet: 1..147	R/W
Baud Rate	Baud Rate	801	uint16	0..5	0 = 9600 1 = 19200 2 = 38400 3 = 57600 4 = 76800 5 = 115200	R/W
Modbus Parity	Modbus Parity	802	uint16	0..2	0 = None 1 = Odd 2 = Even	R/W
Modbus Stopbits	Modbus Stopbits	803	uint16	0..1	0 = 1 Stop Bit 1 = 2 Stop Bits	R/W
Soft Reset	Soft Reset	810	uint16	0..1	0 = Normal 1 = Reset	R/W
Persist	Persist (Store Parameters in Non-Volatile Memory)	811	uint16	0..1	0 = Normal 1 = Persist	R/W
Reload Defaults	Reload Defaults (NOTE: Resets all settings to factory defaults)	812	uint16	0..1	0 = Normal 1 = Factory Defaults	R/W
Service Pin	Service Pin (BACnet Only)	813	uint16	0..1	0 = Normal 1 = Service Pin	R/W
Language Pack Enable	Enables the Language Pack (using language pack it is possible to change the user text entries on the screen)	814	uint16	0..1	0 = English 1 = Language Pack Enabled	R/W
Logo Timer	Time after which the Logo is displayed on the Display after background level is activated. Set to 0 to disable the logo.	815	uint16	0..255 (x1)	1..255 seconds 0 = Logo Disabled	R/W
Firmware Version	Firmware Version	820	uint16	N/A	N/A	R
Serial Number	Serial Number	821	uint16	N/A	N/A	R
Date Code	Date Code	822	uint16	N/A	N/A	R
Product ID	Product ID	823	uint16	N/A	N/A	R
Device ID	BACnet Device ID. Set to 0 to use Automatically generated ID. Follow change with "Persist" and "Reset".	825	uint32	0..5,195,303 (x1)	0..5,195,303	R/W

LORA AUTOMATIC PAYLOAD CONFIGURATION						
Parameter	Description	Modbus Register / BACnet Property	MODBUS HOLDING REGISTER - FUNCTION CODES 03, 06, 16		Value Range / Enumerations	R/W
			Type	Data Range (multiplier)		
Uplink Register 1	LoraWan Automatic Uplink Payload Register 1. Configure to be the register number to be read in the message. (Default: Temp)	850	uint16	1..1000 (x1)	400..1000 (Default 400)	R/W
Uplink Reg 2	LoraWan Automatic Uplink Payload Register 2 (Def: Humidity)	851	uint16	1..1000 (x1)	400..1000 (Default 401)	R/W
Uplink Reg 3	LoraWan Automatic Uplink Payload Register 3 (Def: CO2)	852	uint16	1..1000 (x1)	400..1000 (Default 402)	R/W
Uplink Reg 4	LoraWan Automatic Uplink Payload Register 4 (Def: VOC)	853	uint16	1..1000 (x1)	400..1000 (Default 403)	R/W
Uplink Reg 5	LoraWan Automatic Uplink Payload Register 5 (Def: UI1)	854	uint16	1..1000 (x1)	400..1000 (Default 410)	R/W
Uplink Reg 6	LoraWan Automatic Uplink Payload Register 6 (Def: UI2)	855	uint16	1..1000 (x1)	400..1000 (Default 411)	R/W
Uplink Reg 7	LoraWan Automatic Uplink Payload Register 7 (Def: Y1)	856	uint16	1..1000 (x1)	400..1000 (Default 412)	R/W
Uplink Reg 8	LoraWan Automatic Uplink Payload Register 8 (Def: Y2)	857	uint16	1..1000 (x1)	400..1000 (Default 413)	R/W
Uplink Reg 9	LoraWan Automatic Uplink Payload Register 9 (Def: Y3)	858	uint16	1..1000 (x1)	400..1000 (Default 414)	R/W
Uplink Reg 10	LoraWan Automatic Uplink Payload Register 10 (Def: Y4)	859	uint16	1..1000 (x1)	400..1000 (Default 415)	R/W
Uplink Reg 11	LoraWan Automatic Uplink Payload Register 11 (Def: Calc SP)	860	uint16	1..1000 (x1)	400..1000 (Default 420)	R/W
Uplink Reg 12	LoraWan Automatic Uplink Payload Register 12 (Def: Aux SP)	861	uint16	1..1000 (x1)	400..1000 (Default 421)	R/W
Write Register 1	LoraWan Packaged Write Payload Register 1. Configure to be the register number to be written. (Default: Nominal SP)	862	uint16	1..1000 (x1)	400..1000 (Default 701)	R/W
Write Register 2	LoraWan Packaged Write Payload Register 2. (Def: Aux SP)	863	uint16	1..1000 (x1)	400..1000 (Default 681)	R/W
Write Register 3	LoraWan Packaged Write Payload Register 3. (Def: None)	864	uint16	1..1000 (x1)	400..1000 (Default 0)	R/W
Write Register 4	LoraWan Packaged Write Payload Register 4. (Def: None)	865	uint16	1..1000 (x1)	400..1000 (Default 0)	R/W
Write Register 5	LoraWan Packaged Write Payload Register 5. (Def: None)	866	uint16	1..1000 (x1)	400..1000 (Default 0)	R/W
Write Register 6	LoraWan Packaged Write Payload Register 6. (Def: None)	867	uint16	1..1000 (x1)	400..1000 (Default 0)	R/W
Transmission Interval	Lora Uplink Message Transmission Interval, minutes	847	uint16	1..9 (x1)	0 = 1min 1 = 2min 2 = 3min 3 = 4min 4 = 5min 5 = 6min 6 = 10min (default) 7 = 15min 8 = 30min 9 = 60min	R/W
Lora Version	Reports the Lora Firmware Version	875	uint16	1..9999 (x1)	n/a (V2.03 latest as Apr 25)	R

The following registers are available with Modbus only. The registers combine two parameters to a single 16-bit (2 Bytes) Modbus register.

MODBUS SPECIFIC COMBINATION REGISTERS						
Parameter	Description		MODBUS INPUT REGISTERS - FUNCTION CODE 05 MODBUS HOLDING REGISTER - FUNCTION CODES 03, 16			
			Type	Data Range (multiplier)	Value Range / Enumerations	R/W
Y1/Y2	Combined 16-Bit Register for Outputs Y1 and Y2. E.g. Y1=0x65 (100%), Y2=0x64 (100%) Register=0x6464 (25700)	450	uint16	0..25700 (x1) 0x0000..0x6464	Byte 1:Y1 (0x00..0x64), Byte 2:Y2 (0x00..0x64)	R
Y3/Y5	Combined 16-Bit Register for Outputs Y3 and Y4	451	uint16	0..25700 (x1) 0x0000..0x6464	Byte 1: Y3 (0x00..0x64), Byte 2: Y4 (0x00..0x64)	R
Htg/Clg	Combined 16-Bit Register for Heating and Cooling Demands	452	uint16	0..25700 (x1) 0x0000..0x6464	Byte 1: Htg (0x00..0x64), Byte 2: Clg (0x00..0x64)	R
Device Status	Combined 16-Bit Register for Binary Status of the Device	455	uint16	0..25700 (x1)	Bit0 - DI1, Bit1 = DI2, Bit3 = PIR, Bit4 = Relay, Bit5= Boost, Bit6 = Screen Lock	R

Bacnet Protocol Implementation Statement (PICS) and BACnet Objects

The -BAC versions of the controllers come with BACnet MS/TP communication. The following tables describe the PICS (Protocol Implementation Conformance Statement) and BACnet Objects (Standard and Proprietary). The Proprietary Objects are used for the device configuration.

GENERAL INFORMATION			
Date:	Sep 1, 2022		
Vendor Name:	Senticon Ltd		
Vendor ID:	1374		
Product Name:	xCR Smart Room Controller		
Product Models:	TVRxx, QVRxx		
Applications Software Version:	1.0		
Firmware Revision:	1.0.0		
BACnet Prorocol Revision	1.19		
Product Description:	Smart Room Controller		
BACnet Standard Device Profile:	BACnet Application Specific Controller (B-ASC)		
BACnet Interoperability Blocks Supported:	Data Sharing - ReadProperty-B (DS-RP-B) Data Sharing - ReadPropertyMultiple-B (DS-RPM-B) Data Sharing - WriteProperty-B (DS-WP-B) Data Sharing - COV-B (DS-COVU-B) Device Management - DynamicDeviceBinding-B (DM-DDB-B) Device Management - DynamicObjectBinding-B (DM-DOB-B) Device Management - DeviceCommunicationControl-B (DM-DCC-B)		
Segmentation Capability:	No		
Data Link Layer Options:	MS/TP Master; Supported Baud 9600/19200/38400/57600/76800/115200		
Device Address Binding:	No static device binding supported		
Networking Options:	None		
Character Sets Supported:	ISO 10646 (UTF-8)		
Gateway Options:	None		
Network Security Options:	Non-Secure Device		
Standard Object Types Supported:	Object Type:	Optional Properties	Writeable Properties
	Analog Value:	Description, COV Increment, Relinquish Default	Present Value COV Increment
	Binary Value:	Description, Inactive_Text, Active_Text	Present Value
	Device Object:	Description Active COV Subscriptions Max Master	Object Identifier Object Name APDU Timeout (0...60000) Number Of APDU Retries (0...10) Max Master (1...127)
<p><i>For all supported objects, device does not support CreateObject or DeleteObject.</i></p> <p><i>For Analog Value objects that are classified as read only, there is the following behavior:</i></p> <ul style="list-style-type: none"> - HVAC application overwrites the present value that has been written with the Write Property Service. - In this case, no error message will be sent. <p><i>The device application checks the ranges of the Present Value and the COV Increment of the Analog Objects. For this reason, there is the following behavior:</i></p> <ul style="list-style-type: none"> - No error message, if the limits have been exceeded - Too high values are set to the range maximum - Too small values are set to the range minimum 			

OBJECT TYPE: DEVICE OBJECT				
Object Instance	Property Identifier	Value Range	Default Value	R/W
Device[x]	Object Identifier		MAC_Address	R/W
	Object Name	32 chars max.		R/W
	Object_Type		8	R
	System_Status		Status_Operational	R
	Vendor_Name		Senticon Ltd	R
	Vendor_Identifier		1374	R
	Model_Name		xCR	R
	Firmware_Revision		1.0.0	R
	Application_Software_Version		1.0	R
	Protocol_Version		1	R
	Protocol_Revision		19	R
	Protocol_Services_Supported		See General Information	R
	Protocol_Object_Types_Supporte		See General Information	R
	Object_List		See Objects List	R
	Max_APDU_Length_Accepted		480	R
	Segmentation_Supported		No	R
	APDU_Timeout		6000 ms	R/W
	Number_Of_APDU_Retries		3	R/W
	Max_Master		127	R/W
	Device_Address_Binding			R
Database_Revision		0	R	
Property_List			R	

OBJECT TYPE: ANALOGUE VALUE						
Object Instance	Object Name	Value Range	Relinquish_Default	Units	COV Increment	R/W
AV(0)	Temperature	-40.0..120.0°C / -40.0..258.0°F	-	DEGREES_CELCIUS or DEGREES_FAHRENHEIT	0.0..100 (Default 0.5)	R
AV(1)	Humidity	0..100.0	-	RELATIVE_HUMIDITY	0.0..100 (Default 5)	R
AV(2)	CO2	0..10,000	-	PARTS_PER_MILLION	0.0..100 (Default 50)	R
AV(3)	VOC	0..1,000	-	NO_UNITS	0.0..100 (Default 10)	R
AV(4)	Flow	0..32,000	-	NO_UNITS	0.0..100 Default 1.0	R
AV(5)	UI2	-50.0..120°C / -50..258°F 0..100.0%	-	DEGREES_CELCIUS or DEGREES_FAHRENHEIT or NO_UNITS	0.0..100 Default 1.0	R
AV(6)	Y1	0.0..100.0%	-	PERCENT	5	R/W
AV(7)	Y2	0.0..100.0%	-	PERCENT	5	R/W
AV(8)	Y3	0.0..100.0%	-	PERCENT	5	R/W
AV(9)	Y5	0.0..100.0%	-	PERCENT	5	R/W
AV(10)	Setpoint_Main	0.0..212.0	Nonvol_Setpoint	NO_UNITS	n/a	R/W
AV(11)	Setpoint_Flow	0.0..32000.0	Nonvol_Setpoint	NO_UNITS	n/a	R/W
AV(12)	Setpoint_CO2	0..10000.0	Nonvol_Setpoint	PARTS_PER_MILLION	n/a	R/W
AV(13)	Setpoint_VOC	0..500.0	Nonvol_Setpoint	NO_UNITS	n/a	R/W
AV(15)	Setpoint_Humidity	0..100.0	Nonvol_Setpoint	RELATIVE_HUMIDITY	n/a	R/W
AV(15)	Fan_Speed	0..4.0	Nonvol_FanSpeed	NO_UNITS	1	R/W
AV(16)	Operating_Mode (Occupied/Unocc/Off)	0..2.0	Nonvol_OpMode	NO_UNITS	1	R/W
AV(17)	Network_Decimal	-999.0..999.0	Nonvol_Setpoint	NO_UNITS	n/a	R/W
AV(18)	Network_Integer	0..65535.0	Nonvol_Setpoint	NO_UNITS	n/a	R/W

NOTE: Priority Input 16 is reserved for internal value. If COV increment is set to 0.0 (default), the COV is disabled.

NOTE: In order to override Y1/Y2/Y3/Y5 outputs (priority inputs 1-15), the corresponding output mode has to be set as 'Network'.

NOTE: R = Read Only, R/W = Read/Write

OBJECT TYPE: BINARY VALUE					
Object Instance	Object Name	Description	Present Value Range / Active - Inactive Tex	Relinquish_Default	R/W
BV(0)	DI_2	Digital Input 2 Status	0: InActive (Off) 1: Active (On)	Binary_Inactive	R
BV(1)	PIR	PIR Movement Sensor Status	0: InActive (Off) 1: Active (On)	Binary_Inactive	R
BV(2)	DO_1	Digital Output (Relay) Status	0: InActive (Off) 1: Active (On)	Binary_Inactive	R/W
BV(3)	Boost	Boost Button Status (Active / non-active)	0: InActive (No Boost) 1: Active (Boost)	Binary_Inactive	R
BV(4)	Cooling_Mode	Cooling Mode Override for Heating Stage 1 (Heating/Cooling)	0: InActive (Heating) 1: Active (Cooling)	Binary_Inactive	R/W
BV(5)	Screen_Lock	Locks / Unlocks Screen	0: InActive (Unlocked) 1: Active (Locked)	Binary_Inactive	R/W
BV(6)	Damper Min.	Overrides Damper Min. Position	0: InActive (Unlocked) 1: Active (Locked)	Binary_Inactive	R/W
BV(7)	Damper Max.	Overrides Damper Max. Position	0: InActive (Unlocked) 1: Active (Locked)	Binary_Inactive	R/W
BV(8)	Force Min Flow	Force Minimum Flow (setpoint)	0: InActive (Unlocked) 1: Active (Locked)	Binary_Inactive	R/W
BV(9)	Force Max Flow	Force Maximum Flow (setpoint)	0: InActive (Unlocked) 1: Active (Locked)	Binary_Inactive	R/W

NOTE: Priority Input 16 is reserved for Internal Value.

NOTE: BV(6) - Set Priority Inputs 1-15 to 'null' to allow the user to unlock/lock the device.

PROPRIETARY OBJECT OBJECT NAME / TYPE: "CONFIGx" / 128
The devices have six instances of proprietary Device Configuration objects split as with the configuration tools; Cfg_IO, Cfg_Calibration, Cfg_Display, Cfg_Control_1, Cfg_Control_2, Cfg_System. The devices can be fully configured using the properties of these configuration objects. Full list of available properties are listed in the <i>Device Setup and Modbus/BACnet Communication</i> section tables.

In addition to the generic parameters, the BACnet AV and BV objects have proprietary property to enable COV (Unsubscribed COV) function. For the AV objects the COV increment can be changed from the defaults. For the BV objects data is transmitted when the state changes.

NOTE: Enabling COV increases network load as the messages are broadcasted to all devices. For efficient network performance limit the number of COV objects to minimal and configure routers to allow broadcasts only on the subnets.

BACNET COV OBJECT SETTINGS						
Parameter	Description	BACnet Property	Type	Data Range (multiplier)	Value Range / Enumerations	R/W
AVx COV	AV Object COV Enable Flag x = AV Object Number (AV0..AV9, A15..AV16, AV19..AV22)	100x	uint16	0..1(x1)	0 = COV Disabled 1 = COV Enabled	R/W
BVx COV	BV Object COV Enable Flag x = BV Object Number (BV0..BV4)	110x	uint16	0..1(x1)	0 = COV Disabled 1 = COV Enabled	R/W

Dimensions and Installation

The devices typically mounted on the flat wall surfaces or on the junction boxes. The enclosure has 56/60mm screw distance for standard mounting boxes.

Installation Notes:

- Follow the diagram below to open the enclosure to access the mounting holes and the wiring terminals.
- Install the sensors away from the sources of heat and cool e.g. from direct sunlight or cold external walls.
- Install the sensors at 120-150 cm height for optimal performance.

- For correct movement (PIR) sensor operation consider the location of the sensor carefully.
- Make sure that the cable entries and junction boxes are sealed from air flows. This is the most common reason for inaccuracies in temperature measurement.
- Bring the cables through the dedicated hole (black area) marked on the dimensions drawing.
- If surface mounted cable is required to be used, the top of the enclosure (center) has a thin wall section that can be cut.

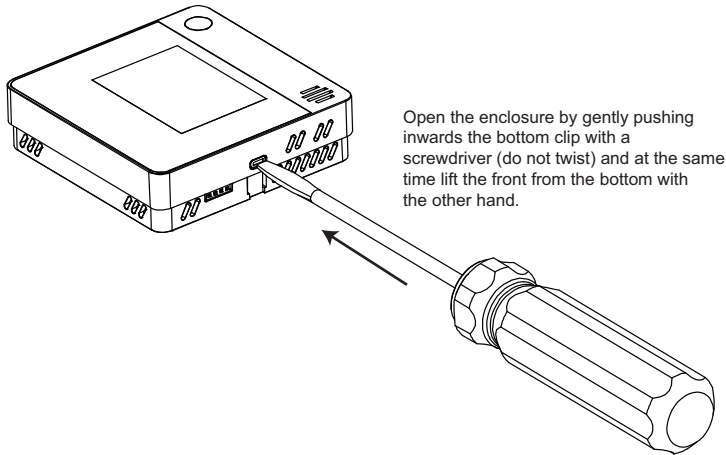

DIMENSIONS

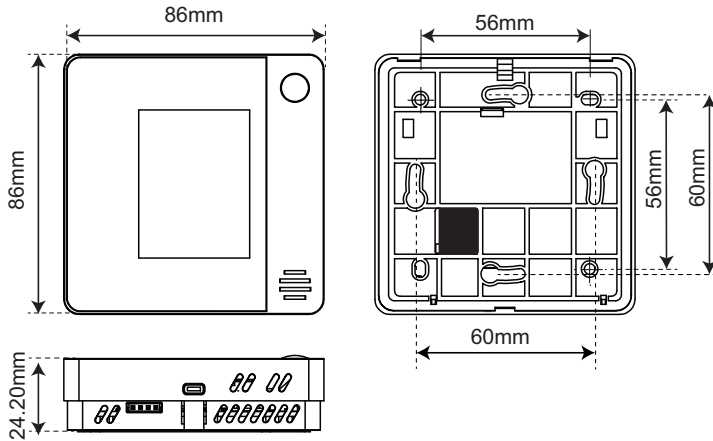

DIMENSIONS (xVR22 SERIES)

