

PS2.05 TCR86 Series Ceiling Mounted Room Controllers for Fan Coil Units, Heat Pumps and Roof Top Units



TCR80 SERIES CONTROLLER



UP TO 2 x TDR20/QDR20
ROOM INTERFACE
PANELS

The TCR86 Series Controllers are ceiling mounted room controllers for controlling fan coil units, heat pumps and roof top units. The controllers have IP65 rated enclosure with cable glands, and are available with 24V power supply. The controllers can be connected to the TDR20/QDR20 room display panels using the USB-C cable, making installation and connection simple. The controller built-in universal inputs can be used with cable sensors. The room interface panels have temperature measurement, setpoint, fan speed, boost function and operating mode selection (configurable). In addition the room interface panels can have optional humidity, VOC, CO2 and occupancy measurements.

The controllers have built-in Modbus RTU, BACnet MS/TP or Wireless LoraWan communication that allow interaction to the BMS systems. The controllers can be configured using Windows Configuration Tool over the USB-SERIAL or wireless Bluetooth BLE-TOOLSET. The controllers can also be configured over the Modbus/BACnet, or using iOS Mobile Phone/iPad application.

Features

- Advanced Room Controllers for fan coil unit, roof top unit and heat pump control applications.
- Connection to TDR20/QDR20 Room Display Interfaces via a USB-C cable
- BACnet MS/TP and Modbus RS485 RTU with up to 60V industrial isolation on RS485 for system integration
- LoraWan Wireless Communications
- 4 x Universal Inputs (temperature/0-10V/digital)
- 2 x Analogue 0..10Vdc Outputs, max 2mA
- 6 x 24V Pilot Relays
- Configuration wirelessly through Smart Configuration Windows Software or Smart Phone iOS App (using Bluetooth Dongles). SmartView SmartPhone App for device interrogation for end users.
- NEMA3 / IP65 Wall/Ceiling Mounted Enclosure with 4 x M16 6-12mm Conduit Entries, 4 x M16 4-8mm Conduit Entries
- Designed for Installers in mind with Spring Loaded pluggable spring-loaded terminal blocks and Sufficient Wiring Space

Technical Specifications

Power Supply:	Power:	24Vac/dc -10%/+15%, max 100mA with the Room Interface Panel
Inputs:	Universal Inputs:	4 x Universal Inputs - RI/AI/DI Application Selected RI = NTC10 Measurement / Resistive AI = 0..10Vdc Input DI = Digital Volt-Free Input
Outputs:	Analogue Outputs:	2 x 0..10Vdc, min. load resistance >5 kOhms (max. 2mA @ 10V)
	Digital Outputs:	6 x 24V Rated Pilot Relays, max 0.5A load
Communication Options:	Physical Interface	1 x RS485 driver with up to 60V industrial Isolation, recommended max 63 devices
	Protocol:	Modbus RTU or BACnet MS/TP (order relevant model)
	Addressing:	Via Bitswitch: 1..127 Via Software: 1..247 for Modbus, 1..127 for BACnet MS/TP
	Settings:	Baud Rate: 9600/19200/38400/76800 (bitswitch), 57600/115200 (software) Modbus Parity: None/Even/Odd, Modbus Stop Bits: 1 or 2
Wireless Communication:	Bluetooth (Option):	Bluetooth Interface to SmartPhone App or BLE USB Dongle (Device Config Tool)
	LoraWan (Option):	LoraWan® Wireless Interface (EU868, US915, AS923) Encrypted LoraWan® 1.0.3 Class C Device with secure OTAA activation with IPEX antenna for long-range communication. Configurable Uplink and Downlink Messages.
Sensor Bus:	Physical Interface	2 x USB-C Connector for the Room Interface Panels (TDR/QDR20) Each connector provides RS485, 0V and 5Vdc Option: 5V, 0V, TX, RX Spring Loaded Terminals Block
Mechanical:	Wiring Terminals:	Spring Loaded Push Fit Terminals, 0.2 to 2.5mm ² / 26 to 12 AWG 4 x M16 and 4 x M20 Cable Glands
	Enclosure:	ABS Plastics - White, NEMA3 / IP65 Rating
	Mounting:	Wall or Ceiling Mounting
	Dimensions	W220 x H140 x D75mm

Model Selection

Refer to the below table to select the required model.

Part Number		SKU# Number					
Example	TCR86-MOD-24-W	8600	1	00	60	10	0 2
Product Name		Product	Product Options				
TCR86	Ceiling Mounted Room Controller, 4UI, 2AO, 6DO, 1 x Room Interface Units	8600					
Serial Communication Option							
	No communication (select when using LoraWan)		0				
MOD	Modbus RS485		1				
BAC	BACnet MS/TP		2				
Wireless Communication Options							
	No Interface			00			
BLE	Bluetooth App Interface			03			
LRA	LoraWan Wireless Interface (select Lora region below)			06			
BLE-LRA	Bluetooth App Interface and LoraWan Wireless Interface (select Lora region)			09			
Zone Sensor Supply							
	USB-C Connector				60		
5V	5V+ Zone Sensor Communications Spring Loaded Terminals				61		
Power Supply Option							
24	24V Power Supply					10	
230	230V Power Supply, 24Vac 8VA available for actuators					11	
Region Options (Lora)							
	Non Lora & EU868MHz Lora (Default)						0
US	US915MHz Lora						1
AS	AS923MHz Lora						2
Colour Options							
W	White						2

Part Number	Description	SKU# Number
Accessories		
USB-C-CAB-6	6m USB-C Male to USB-C Male for Room Interface Units, Black	8510 0 00 0005 01
USB-C-EXT-6	5m USB-C Female to USB-C Male Extension Cable, Black	8520 0 00 0006 01

Wiring Connections

TCR86 WIRING CONNECTIONS

TCR86 WIRING

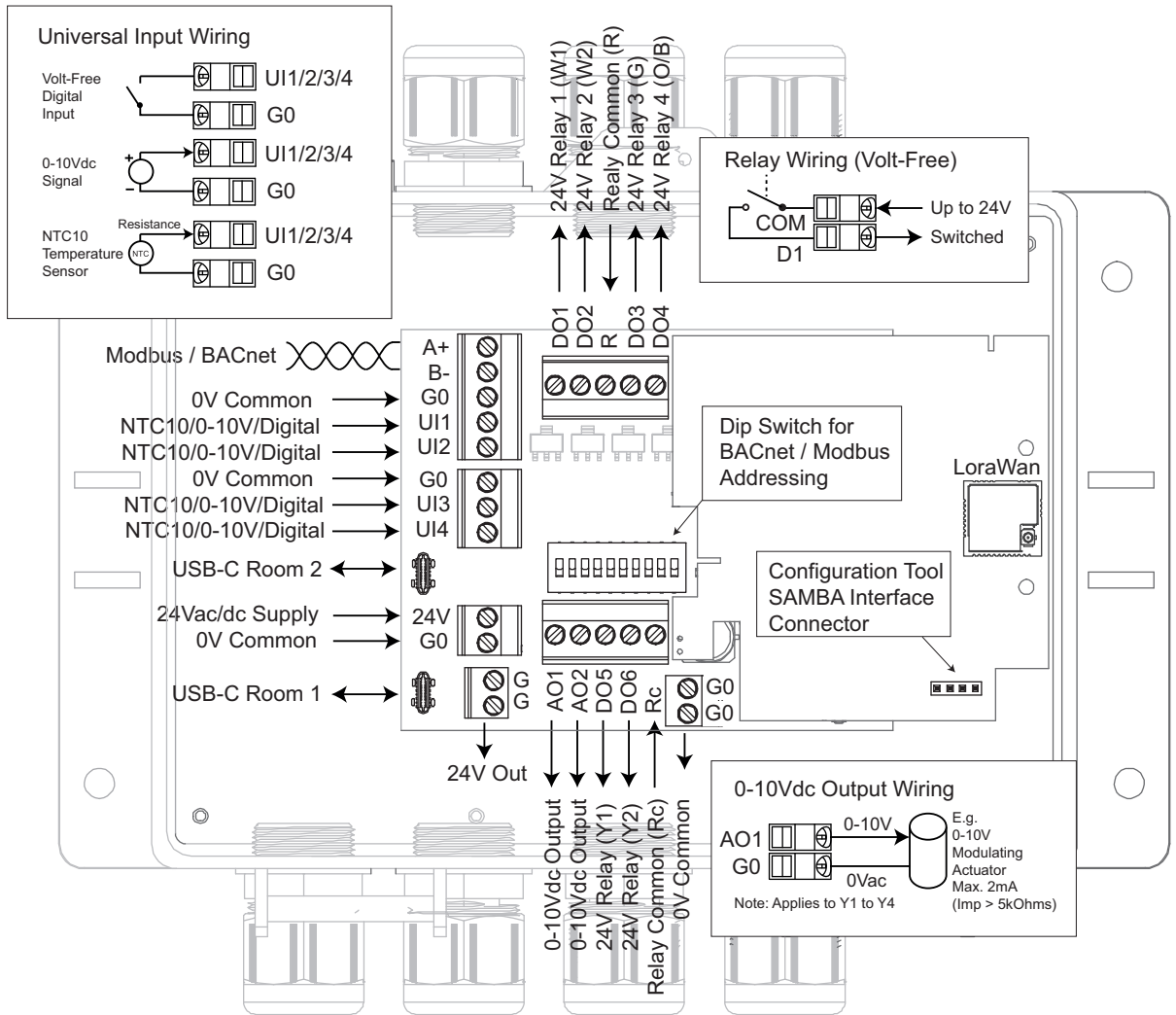

Terminal	Description
A+	Modbus / BACnet RS485 A+
B-	Modbus / BACnet RS485 B-
G0	0V Common
UI1	NTC10/0-10V/Volt-Free Digital Input 1
UI2	NTC10/0-10V/Volt-Free Digital Input 2
G0	0V Common
UI3	NTC10/0-10V/Volt-Free Digital Input 3
UI4	NTC10/0-10V/Volt-Free Digital Input 4
G	24Vac -10/+15% Supply
G0	0V Common

Terminal	Description
DO1	24V Pilot Relay (W1)
DO2	24V Pilot Relay(W2)
R	Pilot Relay Common (DO1-DO4)
DO3	24V Pilot Relay (G)
DO4	24V Pilot Relay (O/B)
G	24Vac Output
AO1	0-10Vdc Output max. 2mA
AO2	0-10Vdc Output max. 2mA
DO5	24V Pilot Relay (Y1)
DO6	24V Pilot Relay (Y2)
Rc	Pilot Relay Common (DO5-DO6)

WIRING GUIDELINES

Make sure that power is switched off and carry out wiring according to the wiring connections drawing and local wiring guidelines.

Room Display Interfaces

The TCR86 series controllers are complemented with the TDR/QDR20 series room display interfaces (up to 2 zones). TDR20/QDR20 interfaces offer measurement of temperature, CO2, humidity, VOC and occupancy (movement). The interfaces allow the user to adjust the temperature setpoint, fan speed, operating mode and also boost the operation. The interfaces can be also used to convey the TCR86 series controller status information as well as utility meter information to the user. The diagram below illustrates the setup.

TCR80 SERIES NETWORK DIAGRAM

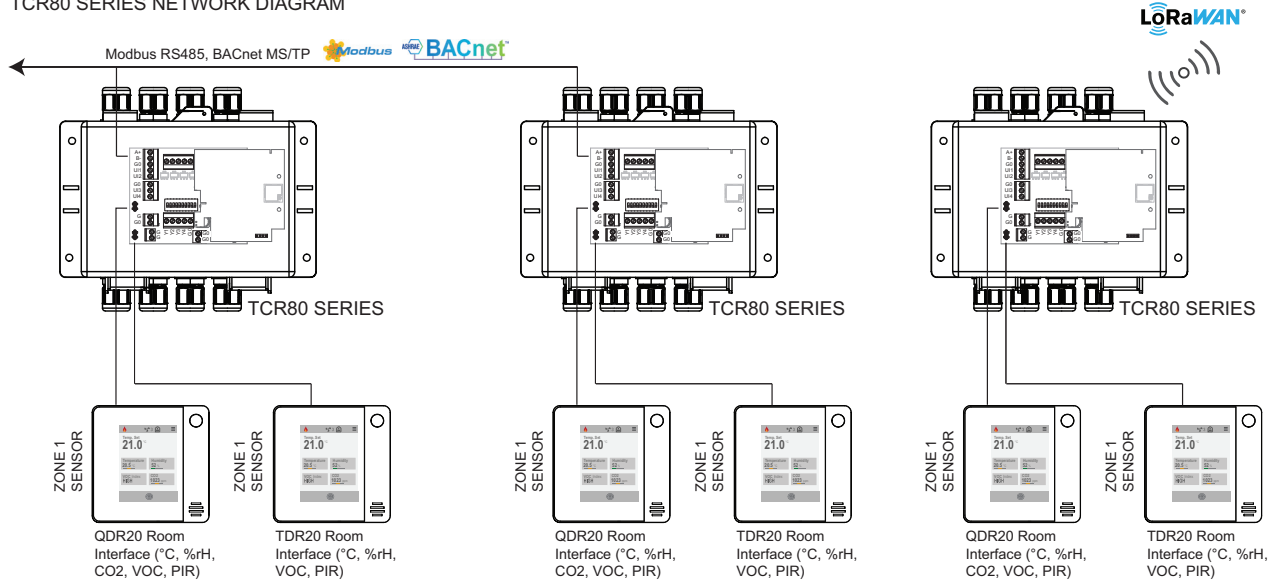

The TCR86 series controllers communicate to the TDR/QDR20 room interfaces using Modbus communication protocol. Zone 1 interface uses Address 1 and Zone 2 interface uses address 2. After connecting the zone interface via USB-C cable (or through optional wiring terminals), activate the interface from the System settings.

The TCR86 series controllers read the following measurements from the TDR/QDR20 Devices.

Parameter	Description	TCR Zone 1 Regs	TCR Zone 2 Regs
ZONE MEASUREMENTS			
Temperature Sensor	TDR/QDR temperature measurement.	400	405
Humidity Sensor	TDR/QDR humidity measurement.	401	406
CO2 Sensor	QDR CO2 reading.	402	407
VOC Sensor	TDR/QDR VOC (Volatile Organic Compound) Index Value	403	408
Dew Point	Calculated Dew Point (calculated at TCR86)	404	409

TCR86 controllers can operate up to two control zones. These control zones use the measurements and overrides from the zone sensors (if enabled). These include the following:-

Parameter	Description	TCR Zone 1 Regs	TCR Zone 2 Regs
Calculated Setpoint	Current Calculated Setpoint for the Zone (can be adjusted from the zone sensor)	420	430
Control Mode	Current Control Mode for the Zone (can be changed from the TDR20/QDR20 interface)	423	433
Fan Mode	Current Fan Level / Control Mode. Manual Off - Manual Speed 1 - Manual Speed 2, Manual Speed 3 or Automatic	429	439

Each Zone Sensor (TDR20/QDR20) can be used to display additional information such as outside air temperature, water and energy consumption figures. These values can be changed via the following registers.

Parameter	Description	TCR Zone 1 Regs	TCR Zone 2 Regs
Network Value 1	Network Value 1 (for displaying network single decimal value).	600	602
Network Value 2	Network Value 2 (for displaying network integer value).	601	603

Control Functions

TCR86 series controllers have flexible control functionality to control fan coil units, rooftop units and heat pumps, with temperature, CO₂, humidity, VOC and occupancy control. The full functionality is achieved by connecting TDR/QDR20 Room Display Interfaces.

CONTROL MODES

The controllers have three control modes:-

- Occupied (Comfort)
- Unoccupied (Relaxed)
- Off (Night)

The controller operating mode is changed via Modbus/BACnet/LoraWan network, via Universal Inputs or via the TDR20/QDR20 Touchscreen Room Interface Unit. The TDR/QDR20 Room Display Interfaces allow the user to change the operating mode via the display, or if the Interface has been fitted with Occupancy sensor, the occupancy detection can change the mode.

On transition from Occupied to Unoccupied/Off modes the Multi-Stage, Auxiliary and Humidity Loop user setpoint adjustments can be automatically reset to nominal values (enable *Reset User Adjustment* parameter 684)

NOTE: The control mode change happens when the controller sees the transition on the state of the command signal. This means that e.g if Digital Input 1 (UI1) overrides the controller to unoccupied mode, the mode can be changed e.g. via network regardless of the current DI1 state.

The control loop outputs (demand signals) are set in different modes as per the below table. Each zone has corresponding control loops and control loop outputs.

Control Mode	Heating and Cooling Stages 1/2/3 Demand	Air Quality CO ₂ and VOC Control Demand	Humidity and Dehumidify Control Demand, Fan Demand
Occupied	Based on control loop with occupied deadzone settings	Based on control loop	Based on control loop
Unoccupied	Based on control loop with unoccupied deadzone settings	Based on control loop	Based on control loop
Off	0% (Frost logic enables heating stages to 100%)	0%	0%

NOTE: On power up the controller starts in Occupied (Comfort) mode.

MULTI-STAGE TEMPERATURE CONTROL

The controller has a multi-stage temperature control logic that meets requirements for advanced temperature control applications using PI-control (Proportional + Integral). Up to three (3) heating and up to three (3) cooling stages are available. Between the heating and cooling stages is a dead-zone where the heating and cooling outputs modulate to closed position providing energy savings in the building when the temperature reaches the setpoint. The heating and cooling deadzones can be separately set to provide asymmetrical control for increased energy savings.

The temperature control is operating in Occupied (comfort) / Unoccupied and Off modes. In unoccupied mode the temperature control is relaxed by increasing the heating and cooling deadzones. In the Off mode the temperature control is switched off (with frost protection active).

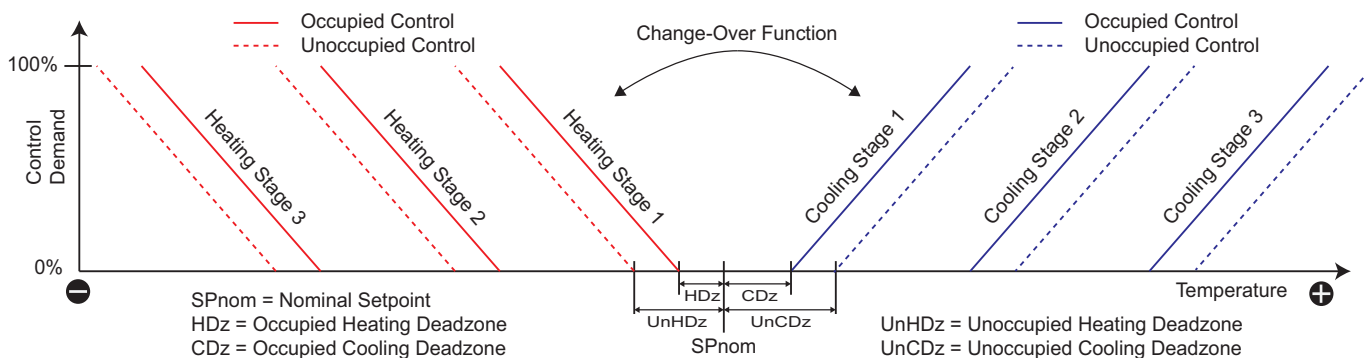

The multi-stage temperature control loop can be configured to control Universal Input 1/2/3/4 temperature/voltage, network value (network temperature), TVD/QDR20 Room Display Temperature or average temperature.

NOTE: TDR20/QDR20 Device ID 1 is used as the Zone Sensor (Modbus Slave 1).

NOTE: The TDR20/QDR20 Room Display Interface is required to be activated in the System Settings menu.

The control loop controls to the Calculated Setpoint. The calculated setpoint is set to nominal setpoint when the nominal setpoint is changed over the Modbus/BACnet/LoraWan network. If the user changes the setpoint on the Room Display, the new setpoint is automatically read to the TCR86 series controller. In case the Room Display for the Zone 1 is active, and the BMS changes the nominal setpoint, this is also sent to the Room Display.

NOTE: *Source: Network value* can only be used in systems where the measurement changes slowly.

FROST PROTECTION (OFF MODE)

In the Night Off mode, the controller automatically monitors the control sensor for low temperature protection (Frost Setpoint). If temperature drops below the frost setpoint, the heating stages for the zone are switched on to 100% until temperature rises 2° above the Frost Setpoint.

Parameter	Description	Value Range / Enumerations
Loop Source	Sets the Control Source for the Multi-Stage Control Loop. Zone Sensor 1 Temperature is read from the Room Device 1. Note: If UI mode is NTC, the control value is as measured temperature. If the UI mode is 0-10V, then 0..10V is scaled to measurement according to UI Input Min/Max scaling parameters. Average Function allows temperature averaging.	0 = Network Value (Reg 600) 1 = Zone Sensor 1 Temperature 2 = UI1 - NTC10 (Default) 3 = UI2 - NTC10 4 = UI3 - NTC10 5 = UI4 - NTC10 6 = UI1 - 0..10Vdc 7 = UI2 - 0..10Vdc 8 = UI3 - 0..10Vdc 9 = UI4 - 0..10Vdc 10 = Average Value
Nominal Setpoint	Control Loop Nominal Setpoint Note: The control loop setpoint can be shifted by the high/low limit reset function.	0.0..212.0 (Default 70.0)
Loop PB	Control Loop Proportional Band (for each stage)	1..500 (Default 5)
IA	Control Loop Integral Action Time (Set to 0 to disable)	0..3600s (Default 600s)
No of Heating Stages	Sets the number of heating stages.	0 = None 1 = 1-Stage 2 = 2-Stages (Default) 3 = 3-Stages
No of Cooling Stages	Sets the number of cooling stages.	0 = None 1 = 1-Stage 2 = 2-Stages (Default) 3 = 3-Stages
Occupied Heating Deadzone (HDz)	Occupied Mode Heating Deadzone.	0.0..30.0 (Default 0.5)
Occupied Cooling Deadzone (CDz)	Occupied Mode Cooling Deadzone.	0.0..30.0 (Default 0.5)
Unoccupied Heating Deadzone (UnHDz)	Unoccupied Mode Heating Deadzone.	0.0..30.0 (Default 5.0)
Unoccupied Cooling Deadzone (UnCDz)	Unoccupied Mode Cooling Deadzone.	0.0..30.0 (Default 5.0)
Frost Setpoint	Off Mode Frost Setpoint.	0.0..60.0 (Default 50.0)

NOTE: If Change-Over function is activated, it can override the Heating Stage1 to operate as Cooling Stage1.

NOTE: Proportional Band is for each stage. E.g. if 3-stages of heating had been selected, and if the Proportional Band has been set as 5, then the Proportional Band across 3-stages of heating is 15.

CHANGE-OVER FUNCTION

The controller can have a change-over function that reverses the corresponding temperature control loop Heating Stage1 (and Cooling Stage1) operation.

The change-over function is activated by the digital input (UI1/UI2/UI3/UI4 digital input), via temperature (UI1/UI2/UI3/UI4 NTC10 temperature), or via network. If temperature is selected, the change-over is active (cooling mode is active) if temperature drops below the change-over low temperature until temperature reaches the change-over high temperature (heating mode becomes active).

Parameter	Description	Value Range / Enumerations
Change-Over Source	Sets the Source for Change-Over Function. Note: As default the Network Command is Off i.e. no change-over function is active. Note: When using Digital Inputs set the corresponding universal input mode to '5 - Digital Network'.	0 = Network Command 1 = UI1 - NTC10 2 = UI2 - NTC10 3 = UI3 - NTC10 4 = UI4 - NTC10 5 = Digital Input 1 (UI1) 6 = Digital Input 2 (UI2) 7 = Digital Input 3 (UI3) 8 = Digital Input 4 (UI4)
Change-Over Low Level	Temperature below which the change-over is active (cooling stage active). Note: Relevant only for NTC Input 1/2/3/4 options.	32..212°F (0..100.0°C) Default 65°F
Change-Over High Level	Temperature above which the change-over is off (heating stage active, no override on control). Note: Relevant only for NTC Input 1/2/3/4 options.	32..212°F (0..100.0°C) Default 72°F
Network Change-Over Override	Heating / Cooling Mode Command from Network. Note: Requires change-over source to be set as Network.	0 = Heating (Default) 1 = Cooling

NOTE: Change-over function is not active in Off Mode.

TIP: Typically configure the control output (AO1/AO2) to Heating Stage1. In normal operation the output provides heating control (i.e. when temperature is below setpoint, there is heating demand). When the change-over is active, the same output provides cooling control (i.e. when temperature is above setpoint, there is cooling demand).

LOW/HIGH LIMIT RESET (CASCADE) CONTROL FUNCTION

The controller has a low/high limit reset control function for each zone that is typically used to protect floor surfaces in case of high underfloor heating temperatures, or prevent condensation in case of cool floor temperatures in high humidity environments such as bathrooms.

NOTE: Low/High limit function only applies in Occupied and Unoccupied modes.

Parameter	Description	Value Range / Enumerations
Reset Control Source	Sets the Temperature Source for the Reset Control Function.	0 = Network Value (Reg 600) 1 = UI1 - NTC10 2 = UI2 - NTC10 3 = UI3 - NTC10 4 = UI4 - NTC10 5 = Disable (Default)
High Limit Setpoint	High Limit Setpoint. Above this limit the setpoint is reduced proportionally according to the ratio and temperature difference.	32..212°F (0..100.0°C) Default 95°F
Low Limit Setpoint	Low Limit Setpoint. Below this limit the setpoint is increased proportionally according to the ratio and temperature difference.	32..212°F (0..100.0°C) Default 59°F
Reset Ratio	Reset ratio used to calculated the Multi-Stage Setpoint reset.	0.0..10.0 (Default 1.0)

MAX FUNCTION

The controller has two max functions that have two inputs. Using the Max Functions it is possible to, for example, configure how fan is controlled (Max 1 Default Settings), or take maximum of cooling control and CO2 control to control fresh air dampers (Max 2 Default Settings).

Parameter	Description	Value Range / Enumerations
ZONE 1 PARAMETERS		
Max Function 1 Source 1	Sets the Source for Input 1 of Maximum Function 1 Default: Heating Stage 1	0 = Network Value (Reg 600)
Max Function 1 Source 2	Sets the Source for Input 2 of Maximum Function 1 Default: Cooling Stage 1	1 = Heating Stage 1 2 = Heating Stage 2 3 = Heating Stage 3
Max Function 2 Source 1	Sets the Source for Input 1 of Maximum Function 2 Default: Cooling Stage 1	4 = Cooling Stage 1 5 = Cooling Stage 2 6 = Cooling Stage 3
Max Function 2 Source 2	Sets the Source for Input 2 of Maximum Function 2 Default: CO2 Demand	7 = CO2 Demand 8 = VOC Demand 9 = Humidity/DeHum Demand 10 = Max Function 1 11 = Max Function 2 12 = Fan Demand

EXPLANATION MAX1 DEFAULT OPERATION

As default the Max1 function reads the Heating Stage 1 and Cooling Stage 1 demand values from the Multi-Stage Control loop. Maximum of these values is then used in the fan control loop to set the fan speed (as Fan Control Source = Max Function 1) i.e. the fan is running when there is either heating or cooling demand.

EC FAN AND 3-SPEED FAN CONTROL

Fan control logic is used to control EC fans and 3-Speed fans. Fan control logic can follow Continuous or Stepped control. In Continuous control when the source (e.g. heating and cooling demand) increases the fan speed increases linearly between speed settings.

When under automatic control if the input demand is less than the minimum level (*Min Fan Speed*) the output will be held at the minimum level. The only exception to this is when the *Fan Off Mode* is set to Off and the input demand is 0% in which case the output will be 0%. The *Max Auto Fan Speed* parameter set the maximum fan speed in automatic mode. This can be overdriven manually by setting the *Fan Speed 1/2/3* levels above the *Max Auto Fan Speed*.

In stepped mode the Fan Speed is set in steps (for EC Fans or 3-Speed Fans) with 5% switching OFF hysteresis.

When the fan control source activates (increases above 0%) the Fan Speed is switched to '*Fan Speed 1*' Level for adjustable delay time ('*Fan Startup Delay*') regardless of the *Min Fan Speed* setting. This allows EC Fans to start to run properly before resuming normal control.

If the *Fan Off Mode* setting is set to Off, the Fan output switches OFF after an adjustable '*Fan Off Delay*' Time.

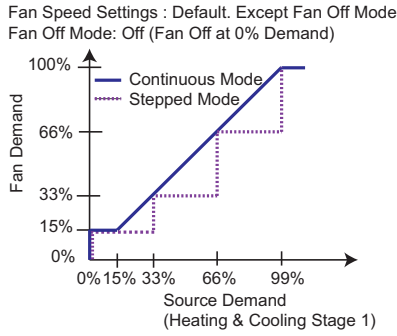
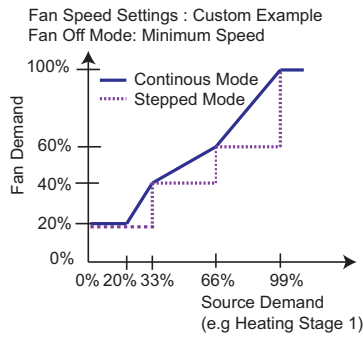
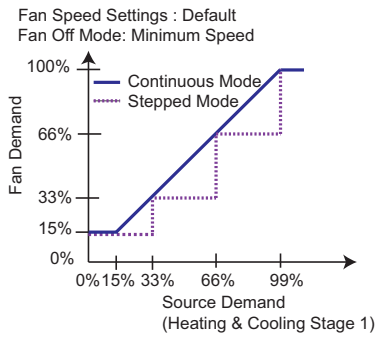

Parameter	Description	Value Range / Enumerations
Fan Control Source	Sets the Source Demand for the Fan Control Function.	0 = Network Value (Reg 600) 1 = Heating Stage 1 2 = Heating Stage 2 3 = Heating Stage 3 4 = Cooling Stage 1 5 = Cooling Stage 2 6 = Cooling Stage 3 7 = CO2 Demand 8 = VOC Demand 9 = Humidity/DeHum Demand 10 = Max Function 1 (Default) 11 = Max Function 2
Min Fan Speed	Sets the Minimum Fan Speed for EC Fans	0..100% (Default 15%)
Fan Speed 1	Sets the Fan Speed 1 for EC Fans (when source 33%)	0..100% (Default 33%)
Fan Speed 2	Sets the Fan Speed 2 for EC Fans (when source 66%)	0..100% (Default 66%)
Fan Speed 3	Sets the Fan Speed 3 for EC Fans (when source 99%)	0..100% (Default 100%)
Fan Mode	Sets the EC Fan Mode. Continuous Mode scales the fan demand based on the source and Fan Speed 1/2/3 settings. In Stepped mode the fan speed steps according to Fan Speed 1/2/3 settings. In stepped mode the Fan Speed switching hysteresis is 5%.	0 = Continuous Mode 1 = Stepped Mode (Default)
Fan Off Mode	Configures if the Fan is running at minimum level or is off when the fan control demand is at 0% .	0 = Off (Default) 1 = Minimum Speed
Fan Off Delay	Switch OFF delay when the source demand drops to 0 (and Fan Off Mode is set to Off).	0..600 seconds (Default 0)
Fan Startup Delay	Fan Startup when the source demand increases above 0%. During the delay the fan runs at Fan Speed 1 setting.	0..600 seconds (Default 10)
Fan Levels	Sets the number of Fan Levels for stepped fan control.	0 = 0-1-A (Default) 1 = 0-1-2-A 2 = 0-1-2-3-A
Max Auto Fan Speed	Maximum Fan Speed in Automatic Control Mode	0..100% (Default 100%)

MANUAL FAN SPEED CONTROL

If TDR20/QDR20 Room Display Interface is connected to the controller, the TCR86 controller reads the current fan level from the Room Display and sets the fan control logic to follow this. In essence values 0-3 are indicating manual fan speed overrides (no automatic control), and value 4 indicates automatic fan speed control.

The Fan Level override parameter (from BMS) allows the fan speed to be overridden from the network. If this value is changed, it will also be sent to the TDR20/QDR20 room interface device.

CO2 (CARBON DIOXIDE) CONTROL

TCR86 series provides CO2 control loop using PI (Proportional + Integral) control logic. The control loop output can be connected to the physical outputs to e.g. control the fresh air damper using analogue outputs.

The CO2 measurement can be read from the QDR20 Room Display Interface, from Universal Input or from the network.

With Proportional Control when the CO2 measurement increases above the CO2 Setpoint, the CO2 control demand (and control output) increases proportionally based on the Proportional Band (PB) setting - see image.

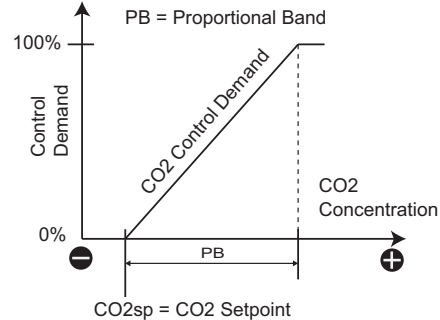

Often fresh air damper is also used to provide cool air to the building. In this case the damper is linked to both Cooling Stage temperature control and CO2 control. This can be achieved using so called 'Maximum VAV' logic. With TCR86 Series the Max Function can be used to take the maximum of Cooling and CO2 demands and link it to an output (*Max Function 2* is configured as default for this).

Parameter	Description	Value Range / Enumerations
CO2 Control Source	Sets the Source for the CO2 Control Zone CO2 Measurement is from Room Display Interface 1. Note: If set to UI1/UI2/UI3/UI4, then 0..10V is scaled to measurement according to UI Input Min/Max scaling parameters.	0 = Network Value (Reg 601) 1 = Zone Sensor 1 CO2 Measurement (Default) 2 = UI1 - 0..10V 3 = UI2 - 0..10V 4 = UI3 - 0..10V 5 = UI4 - 0..10V
CO2 Setpoint	CO2 Control Setpoint.	0..10,000 (Default 750)
CO2 PB	CO2 Control Proportional Band.	1..10,000 (Default 500)
CO2 IA	CO2 Control Integral Action Time (Set to 0 to disable).	0..3600s (Default 0s)

VOC AIR QUALITY CONTROL

TCR86 Series controllers can also control VOC (Organic Volatile Compound). With VOC PI (Proportional + Integral) control logic it is possible to control the air quality by e.g. increasing ventilation on high VOC concentration. The VOC control logic operates in Direct sequence ie. when the VOC Index increases the VOC Control Demand increases proportionally. Each zone VOC measurement is received from the corresponding Room Display Interface, or from Network.

Parameter	Description	Value Range / Enumerations
VOC Control Source	Sets the Source for the VOC Control. VOC Measurement is from Room Display Interface 1.	0 = Network Value (Reg 601) 1 = Zone Sensor 1 VOC Measurement (Default)
VOC Setpoint	VOC Control Setpoint	0..500 (Default 100)
VOC PB	VOC Control Proportional Band	1..500 (Default 100)
VOC IA	VOC Control Integral Action Time (Set to 0 to disable)	0..3600s (Default 0s)

HUMIDITY CONTROL

The controller has a single stage humidity / dehumidity PI-control loop that calculates the loop demand based on the TDR/QDR20 humidity measurement or external humidity sensor measurement. Set the *Humidity Mode* to *Humidify* for humidifying action and to *De-Humidify* for dehumidifying action. Humidity measurement is received from the Room Display Interface from corresponding zone, or from Universal Input/Network.

Parameter	Description	Value Range / Enumerations
Humidity Source	Sets the Source for the Humidity Control. Humidity Measurement is from Room Display Interface 1. Note: If set to UI1/UI2/UI3/UI4, then 0..10V is scaled to measurement according to UI Input Min/Max scaling parameters.	0 = Network Value (Reg 600) 1 = Zone Humidity Measurement (Default) 2 = UI1 - 0..10V 3 = UI2 - 0..10V 4 = UI3 - 0..10V 5 = UI4 - 0..10V
Humidity Setpoint	Humidity Control Loop Setpoint	0..100% (Default 50%)
Humidity PB	Humidity Control Proportional Band	1..100% (Default 20%)
Humidity IA	Humidity Control Integral Action Time (Set to 0 to disable)	0..3600s (Default 0s)
Humidity Mode	Humidity Loop Control Mode	0 = Humidify (Reverse) 1 = De-Humidify (Direct)

DEHUMIDIFICATION USING COOLING

In addition the controller has dehumidification function where the multi-stage temperature control Cooling Stage 2 is overridden to 100% when the dehumidification demand is 50% (and the Humidity Interlock function is enabled). The Cooling Stage 2 returns to automatic control after dehumidification demand drops to 0%. To control the switch on humidity and switch off humidity, it is recommended that the humidity PI-control loop is set to operate in P-mode (set Integral Action to 0 to disable it). Using this function it is possible to condition the supply air simultaneously with heat and cool (and dehumidify in the process, ref Mollier Diagram).

Parameter	Description	Value Range / Enumerations
Z1 Humidity Interlock	Enables Cooling Stage 2 Interlock on High Humidity (at 50% humidity loop demand) for Zone 1 Humidity Loop	0 = Disabled (Default) 1 = Enabled

CONDENSATION CONTROL

In cooling systems (e.g. chilled beam) when the pipe surface temperature drops reaching the dew point, this creates a condensation risk. The TCR86 Series controller have protection logic to minimise the condensation. This can be activated by enabling '*Digital Cooling Disable*' on the Universal Inputs. In this mode the universal input operates as volt-free digital input. When the input closes the controller switches the multi-stage control loop Cooling Stage Demands to 0% until the volt-free input is off (open contact).

Alternative method is to use a resistive condensation sensor where the resistance drops when condensation occurs, and resistance increases when the sensor is dry. To activate this function set the Universal Input mode to '*Digital Cooling Disable*'. When resistance drops approximately below 100kOhms the condensation risk is active and when the resistance increases above approx. 150kOhms, there is no condensation risk. In case of condensation risk the multi-stage Cooling Stage Outputs are set to 0%

DEW POINT CONDENSATION CONTROL

If humidity sensor is fitted (-RH option) on the TDR20/QDR20 Room Display Interfaces, the dew point temperature can be calculated by the relative humidity and temperature. The TCR86 series controllers have unique function, where the room temperature and humidity is used in calculation of the dew point temperature. This temperature is then compared to the pipe temperature (set UI1/2/3/4 to Dew Point mode) and when pipe temperature is dropping closer to the dew point temperature, the cooling outputs are **proportionally limited**, until the dew point danger has dissipated. The diagram on the right illustrates the maximum cooling output as a function of Dew Point temperature and Pipe temperature (calculated by *Dew Point Offset - OSdp* and *Dew Point Range - Rdp* parameters).

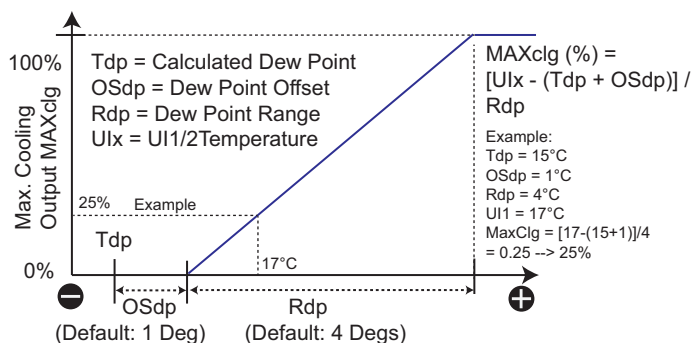

Alternatively by changing the *Dew Point Mode* parameter to **On/Off**, the cooling outputs are switched OFF at $Tdp + OSdp$ and return back to normal control at $Tdp + OSdp + Rdp$.

NOTE: The controller uses approximation method for the dew point temperature calculation. This only works when the relative humidity is more than 50% rH.

NOTE: It is possible to use UI measurements to calculate the Dew Point. To activate this set the Multi-Stage Control Loop Source to corresponding temperature sensor, and Humidity Control Loop Source to corresponding remote humidity sensor measurement.

Parameter	Description	Value Range / Enumerations
Z1 Dew Point Range	Z1 Dew Point calculation range where the Dew Point based cooling max. position calculates linearly from 100% to 0%	0..10 Degrees (Default 4)
Z1 Dew Point Mode	Z1 Dew Point Mode Selection	0 = On-Off 1 = Proportional (Default)
Z1 Dew Point Offset	Z1 Dew Point Offset (from the calculated Dew Point) where the Dew Point based calculated max. position is 0%	0..5.0 Degrees (Default 1.0)

BOOST FUNCTION

The TCR86 series controller mode can be Boosted to Occupied by TDR20/QDR20 user interfaces. Please refer to TDR20/QDR20 documentation.

ECONOMIZER (OUTSIDE AIR FREE COOLING)

The controller has outside air Economizer function that allows the outdoor damper to be controlled by the cooling stage demand (*Economizer Source*) when the outside air temperature (*Economizer Limit Temp Source*) is below the *Economizer Limit Setpoint*. When the outside temperature exceeds the *Economizer Limit Setpoint + 2 degrees* the Economizer output is set to be at the *Economizer Min Output* level.

To activate Economizer on the analogue output, set the corresponding analogue output to 29:*Economizer*.

NOTE: In the Off controller mode the Economizer output is set to 0%.

Parameter	Description	Value Range / Enumerations
Ecomiser Source	Sets the Economizer Control Source (typically Cooling Stage 1)	0 = Cooling1 (Default) 1 = Cooling2 2 = Cooling3
Economizer Limit Temp Source	Temperature that the Economizer function is monitoring (typically outside air temperature sensor).	0 = None (Default) 1 = UI1-NTC10 2 = UI2-NTC10 3 = UI3-NTC10 4 = UI4-NTC10
Economizer Limit Temp	Temperature Limit for the Economizer Output to Modulate	0..212.0 (Default 60°F)
Economizer Min. Output	Minimum Output Level for the Economizer (min. damper position)	0..1000 (Default 15)

MINIMUM DISCHARGE TEMPERATURE CONTROL

The Economizer function can also monitor the Air Discharge Temperature (set *Discharge Temp Source* to activate). If the discharge temp drops below *Discharge Min Temp*, the output is reduced by the amount set in the *Discharge Limit Band*. E.g. if Discharge Limit Band is 2 degrees then if Discharge Air Temp is 2 degrees below the Discharge Min Temp, the damper position is limited to the *Economizer Min Output* level.

Parameter	Description	Value Range / Enumerations
Discharge Temp Source	Discharge Temperature to be monitored	0 = None (Default) 1 = UI1-NTC10 2 = UI2-NTC10 3 = UI3-NTC10 4 = UI4-NTC10
Discharge Min Temp	Min. Temperature Limit for Discharge Temperature	0..212.0 (Default 60°F)
Discharge Limit Band	Discharge Limit Band (to modulate the Economizer output to min. position)	0..500.0 (Default 2.0)

HEATING STAGE LOCKOUT FUNCTIONS

COMPRESSOR LOCKOUT (HEATING STAGE 1 & HEATING STAGE 2 LOCKOUT)

The controller can monitor outside air temperature (791 Economizer Limit Temp Source). If the outside air temperature drops below the Compressor OAT Limit temperature, the heating stages 1 and 2 are force to 0% (stage 1 and stage 2 outputs are switched off). The logic has 2 degrees hysteresis.

HEATING STAGE3 LOCKOUT (SUMMER LOCKOUT)

The controller can monitor outside air temperature (791 Economizer Limit Temp Source). If the outside air temperature exceeds the Htg3 Lockout Temp limit, the Heating Stage 3 is switched to 0% (switched off).

Parameter	Description	Value Range / Enumerations
Compressor Lockout Enable	Compressor Lockout (Heating Stage 1 and 2) Enable	0 = Disabled (Default) 1 = Enabled
Compressor OAT Low Limit	Temperature Limit to Switch Heating Stages 1 and 2 to 0%	0..212.0 (Default 25°F)
Htg3 Lockout Enable	Heating Stage 3 Lockout Enable	0 = Disabled (Default) 1 = Enabled
Htg3 Lockout Temp	Temperature Limit to Switch Heating Stage 3 to 0%	0..212.0 (Default 60°F)

AVERAGE FUNCTION

Average Function can be used to average multiple measurements, and then use this value in the control logic.

Parameter	Description	Value Range / Enumerations
Measurement 1	Sets the Source for Average Measurement 1.	0 = Disabled (Default)
Measurement 2	Sets the Source for Average Measurement 2.	1 = UI1
Measurement 3	Sets the Source for Average Measurement 3.	2 = UI2
Measurement 4	Sets the Source for Average Measurement 4. NOTE: Options 1-4 use Register 460-463 values allowing averaging to be done both NTC10 and voltage.	3 = UI3
		4 = UI4
		5 = Z1 Temperature
		6 = Z2 Temperature

OUTPUT EXERCISE FUNCTION

The TCR86 series controllers have Valve Exercise function that allows each of the analogue outputs to be exercised automatically in case of inactivity (meaning output remains at 0% or 100% for the specified time). The inactivity setting can be set between 1..15 days.

Parameter	Description	Value Range / Enumerations
Valve Exercise Period	Sets the period of inactivity to activate the corresponding output.	0..15 days (Default 14 days)
AO1 Exercise Time	Analogue Output 1 Exercise Time. After configured period of inactivity, the output is driven to 50% for the AO1 Exercise Time	0..15 Minutes (Default: 0) 0 = Disabled
AO2 Exercise Time	Analogue Output 2 Exercise Time. After configured period of inactivity, the output is driven to 50% for the AO2 Exercise Time	0..15 Minutes (Default: 0) 0 = Disabled

Universal Input Configuration

Universal Input can be configured to operate as NCT10 (resistive), Dew Point Sensor, Analogue (0..10V), Condensation Sensor (Resistive) or Digital On/Off. Configure and wire inputs as required by the application operation using the diagram as guidance.

NTC10: Use this option to measure temperature using NTC10 temperature sensors. For control loops to use NTC10, select NTC10 in the control loop source parameters.

Dew Point Sensor: Uses the NTC10 Sensor for Dew Point Calculation Logic for the selected zone.

Digital Modes: Select as appropriate to override the controller operation modes.

Condensation Sensor Option: Uses resistive condensation sensor.

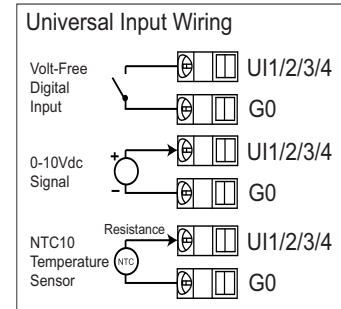

Parameter	Description	Value Range / Enumerations
UI1 Mode	Sets the Universal Input 1 Mode.	0 = Not Used 1 = 0..10V (0..100%) 2 = NTC10 (Default) 3 = Dew Point (NTC10) 4 = Not Applicable 5 = Digital - Network 6 = Digital - Z1 Disable Cooling / Resistive Condensation Sensor 7 = Not Applicable 8 = Digital - Occupied 9 = Digital - Unoccupied 10 = Digital - Off 11 = Digital - Unocc/Occ 12 = Digital - Off / Occ
UI2 Mode	Sets the Universal Input 2 Mode.	
UI3 Mode	Sets the Universal Input 3 Mode.	
UI4 Mode	Sets the Universal Input 4 Mode. Note: Options 8,9,10 override to selected controller mode on OFF to ON transition. Note: Option 11/ overrides to Occupied Mode on ON transition and Unoccupied Mode on OFF transition. Note: Option 12 overrides to Occupied Mode on ON transition and Off Mode on OFF transition. Note: When setting Universal Input to Digital modes, reset (apply changes) is required after the change to activate the correct state.	
UI1 Scale Min.	Sets the scaling for Min. Measurement when UI1 @ 0V (0%)	0.0..3000.0 (Default 0)
UI1 Scale Max.	Sets scaling for the Max. Measurement when UI1 @ 10V (100%)	0.0..3000.0 (Default 100.0)
UI2 Scale Min.	Sets the scaling for Min. Measurement when UI2 @ 0V (0%)	0.0..3000.0 (Default 0)
UI2 Scale Max.	Sets scaling for the Max. Measurement when UI2 @ 10V (100%)	0.0..3000.0 (Default 100.0)
UI3 Scale Min.	Sets the scaling for Min. Measurement when UI3 @ 0V (0%)	0.0..3000.0 (Default 0)
UI3 Scale Max.	Sets scaling for the Max. Measurement when UI3 @ 10V (100%)	0.0..3000.0 (Default 100.0)
UI4 Scale Min.	Sets the scaling for Min. Measurement when UI4 @ 0V (0%)	0.0..3000.0 (Default 0)
UI4 Scale Max.	Sets scaling for the Max. Measurement when UI4 @ 10V (100%)	0.0..3000.0 (Default 100.0)

UI1/UI2/UI3/UI4 Input Minimum and Maximum scaling parameters are used to scale 0..10V signal to the measurement. E.g. typical humidity transmitters scaled 0..100%rH measurement to 0..10V on their output. In this case set the *Scale Min.* parameter to 0 and *Scale Max.* parameter to 100.

In case of CO2 transmitter, these scale the 400..2,000ppm reading to 0..10V. In this case set the *Scale Min.* parameter to 400 and *Scale Max.* parameter to 2,000. Other example, if the CO2 transmitter uses range 0..5,000ppm, set *UI Scale Max.* to 3,000 and *UI Voltage Max* to 6V. This scales input to operate 0..6V = 0..3,000ppm.

NOTE: Using the scaling it is possible also connect pressure sensors to the controller. The controllers have also advanced UI1/UI2/UI3/UI4 voltage clamping settings that can be used to scale e.g. input voltage for e.g. 0..10V = 0..5000ppm CO2 sensors.

Analogue Output and Valve Control Options

0 - 10V OUTPUT CONFIGURATION AND SCALING

The Y1/Y2/Y3/Y4 0..10V outputs can be configured to control based on the options in the below table. In addition each output can be scaled between minimum and maximum limits. Reversing the limits is also possible which will reverse the output voltage (e.g. for situations where the 0..10V valve signal closes the valve instead of opening it).

TIP: By setting minimum output position it is possible e.g. set minimum fresh air level to air dampers.

NOTE: At Night Off mode the outputs switch to 0V (or 10V if reverse mode has been activated) for the corresponding Zone related outputs.

Parameter	Description	Value Range / Enumerations
AO1 Output Mode	AO1 Output Configuration Default: Heating Stage 1	0 = Network Value 1 = Heating Stage 1
AO2 Output Mode	AO2 Output Configuration Default: Economizer	2 = Heating Stage 2 3 = Heating Stage 3 4 = Cooling Stage 1 5 = Cooling Stage 2 6 = Cooling Stage 3 7 = CO2 Demand 8 = VOC Demand 9 = Humidity/DeHum Demand 10 = Max Function 1 11 = Max Function 2 12 = Fan Demand 13 = 6-Way Valve 14 = Reverse 6-Way Valve 15 to 28 = Not Applicable 29 = Economizer
Y1 Minimum	Y1 Output Minimum Level	0.0..100.0% (Default 0%)
Y1 Maximum	Y1 Output Maximum Level	0.0..100.0% (Default 100%)
Y2 Minimum	Y2 Output Minimum Level	0.0..100.0% (Default 0%)
Y2 Maximum	Y2 Output Maximum Level	0.0..100.0% (Default 100%)
Y3 Minimum	Y3 Output Minimum Level	0.0..100.0% (Default 0%)
Y3 Maximum	Y3 Output Maximum Level	0.0..100.0% (Default 100%)
Y4 Minimum	Y4 Output Minimum Level	0.0..100.0% (Default 0%)
Y4 Maximum	Y4 Output Maximum Level	0.0..100.0% (Default 100%)

6-WAY VALVE CONTROL

The 6-way valve option allows the controller to control 6-way valves that can be used for both heating and cooling control, simplifying heating/cooling coil structure. The principle of 6-way valve control is shown in the diagram. To activate the 6-way valve control the 0..10V output (AO1/AO2) is set to '6-way valve'. It is possible to modify the 6-way valve control parameters to suit the different 6-way valve manufacturers. The default settings are provided for Belimo 6-way valve.

Using the 'Z1 Reverse 6-Way Valve' option the Sequence 1 and Sequence 2 are swapped. This allows the controller to be configured to suit regardless of the 6-way valve piping.

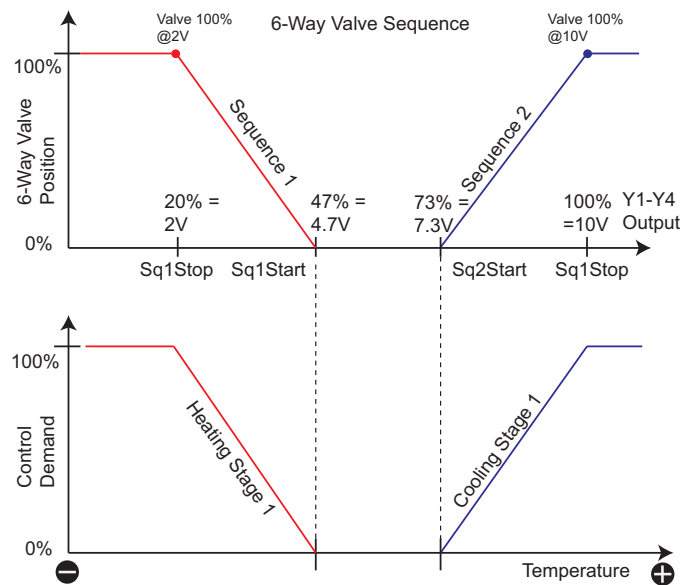

The table below illustrates the switching parameters for the 6-way control.

Parameter	Description	Value Range / Enumerations
Sequence 1 Start Value (Sq1Start)	6-Way Valve Sequence 1 Start Voltage. With setting '6-Way Valve' Main Loop Heating Stage 1 at 0% Demand.	0..100% (Default 47% = 4.7V)
Sequence 1 Stop Value (Sq1Stop)	6-Way Valve Sequence 1 Stop Voltage. With setting '6-Way Valve' Main Loop Heating Stage 1 at 100% Demand.	0..100% (Default 20% = 2V)
Sequence 2 Start Value (Sq2Start)	6-Way Valve Sequence 2 Start Voltage. With setting '6-Way Valve' Main Loop Cooling Stage 1 at 0% Demand.	0..100% (Default 73% = 7.3V)
Sequence 2 Stop Value (Sq2Stop)	6-Way Valve Sequence 2 Stop Voltage. With setting '6-Way Valve' Main Loop Cooling Stage 1 at 100% Demand.	0..100% (Default 100% = 10V)

Digital Output Control Options

DIGITAL RELAY OUTPUT CONTROL OPTIONS

The TCR86 series controllers have 6 x 24V Pilot Relays that are typically used for Heating Stage 1, Heating Stage 2, Cooling Stage 1, Cooling Stage 2, Fan Enable and Compressor/Heat Pump Reverse control.

NOTE: The relay operation can be reversed for each output.

RELAY MINIMUM OFF TIME

By setting the corresponding relay minimum off time it is, the relay output is not activated until the timer has elapsed.

Parameter	Description	Value Range / Enumerations
DO1 Mode	Digital Relay Output 1 Configuration Default: Heating Stage 1	0 = Network Value 1 = Heating Stage 1 2 = Heating Stage 2 3 = Heating Stage 3 4 = Cooling Stage 1 5 = Cooling Stage 2 6 = Cooling Stage 3 7 = CO2 Demand 8 = VOC Demand 9 = Humidity/DeHum Demand 10 = Max Function 1 11 = Max Function 2 12 = Fan Demand 13 = Fan Speed 1 14 = Fan Speed 2 15 = Fan Speed 3 16 to 30: Not Applicable 31 = None 32 = Cooling Active 33 = Heating Active
DO2 Mode	Digital Relay Output 2 Configuration Default: Heating Stage 2	
DO3 Mode	Digital Relay Output 3 Configuration Default: Fan Speed 1	
DO4 Mode	Digital Relay Output 4 Configuration Default: Cooling Active Note: With options 13-15, set Fan Mode = Stepped.	
DO5 Mode	Digital Relay Output 2 Configuration Default: Cooling Stage 1	
DO6 Mode	Digital Relay Output 3 Configuration Default: Cooling Stage 2	
DO1 Direction	Digital Output 1 Direction	0 = Normal (Default) 1 = Reverse
DO2 Direction	Digital Output 2 Direction	
DO3 Direction	Digital Output 3 Direction	
DO4 Direction	Digital Output 4 Direction	
DO5 Direction	Digital Output 5 Direction	
DO6 Direction	Digital Output 6 Direction	
DO ON Value	The value at Relay Output Switches ON.	0..100% (Default 50%)
DO OFF Value	The value at Relay Output Switches OFF	0..100% (Default 0%)
DO1 Min Off Time	Digital Output 1 Min Off Time	0..255 Mins (Default 0)
DO2 Min Off Time	Digital Output 2 Min Off Time	
DO3 Min Off Time	Digital Output 3 Min Off Time	
DO4 Min Off Time	Digital Output 4 Min Off Time	
DO5 Min Off Time	Digital Output 5 Min Off Time	
DO6 Min Off Time	Digital Output 6 Min Off Time	

Wireless Interfaces

BLUETOOTH WIRELESS INTERFACE

With the -BLE option the devices are fitted with integrated Bluetooth Low Energy. The Bluetooth interface provides wireless connection point to SmartPhone app to be able to interrogate and change the controller settings. Using the SmartView application the end users can change the device settings and see the current measurements. The SmartView application can be used as a complement to the display, or with non-display versions it can be used as the user interface.

LORAWAN® WIRELESS INTERFACE

With the -LRA option the devices are fitted with LoraWan® interface. The LoraWan® interface allows the devices to be connected to the LoraWan system wirelessly using Senticon's standard payload format.



The LoraWan® enabled devices will automatically connect to the network on power up. The connection attempts are staggered automatically based on the device serial number to ensure network performance on large systems. The devices will automatically send the device data (temperature, humidity, CO2, VOC etc. - see below table for default configuration) on scheduled intervals (1 to 60 minutes, default 10 minutes).

LoraWan Uplink Register	DEFAULT REGISTERS		
	Parameter	Description	TCR86 Def Reg
1 - 850	Temperature Sensor	Zone 1 TDR/QDR Sensor Temperature Measurement.	400
2 - 851	Humidity Sensor	Zone 1 TDR/QDR Humidity Measurement.	401
3 - 852	CO2 Sensor	Zone 1 TDR/QDR CO2 Reading.	402
4 - 853	VOC Sensor	Zone 1 TDR/QDR VOC (Volatile Organic Compound) Index	403
5 - 854	Temperature Sensor	Zone 2 TDR/QDR Sensor Temperature Measurement.	405
6 - 855	Humidity Sensor	Zone 2 TDR/QDR Humidity Measurement.	406
7 - 856	CO2 Sensor	Zone 2 TDR/QDR CO2 Reading.	407
8 - 857	VOC Sensor	Zone 2 TDR/QDR VOC (Volatile Organic Compound) Index	408
9 - 858	AO1	Analogue Output Y1	464
10 - 859	AO2	Analogue Output Y2	465
11 - 860	Ui1	Universal Input 1	461
12 - 861	U22	Universal Input 2	462

It is also possible to write to any parameter on the device using Senticon's packaged write message - please refer to Senticon LoraWan Payload Specification for further details.

LoraWan DownLink Register	DEFAULT REGISTERS		
	Parameter	Description	TCR86 Def Reg
1 - 862	Nominal Setpoint	Nominal Setpoint	701
2 - 863	Disabled	Disabled	0 - Disabled
3 - 864	Disabled	Disabled	0 - Disabled
4 - 865	Disabled	Disabled	0 - Disabled
5 - 866	Disabled	Disabled	0 - Disabled
6 - 867	Disabled	Disabled	0 - Disabled

Device Setup and Modbus/BACnet Communications

The devices are available with Modbus RTU or BACnet MS/TP communication for system integration. Please also note that the devices can be configured via Modbus or via BACnet MS/TP. Alternatively the devices can be configured locally using via PC Based Smart Config Tool or via iOS Smart Phone Application. Using any of these methods the device settings can be altered to suit the site requirements and the current device status can be interrogated.

Modbus and BACnet communication is carried out over RS485 serial network.

The Windows Smart Config Tool and iOS Smart Phone Application are connected to the device using Bluetooth dongle set (BLE-TOOLSET) that are plugged into the PC USB port and to the device (connection to device illustrated below). If the device is supplied with Built-In Bluetooth App interface (an option), then this can also be used for the tool communication connection

MODBUS / BACNET NETWORK SETUP

NOTE: Modbus RS485 or BACnet MS/TP versions are hardware specific models. It is not possible to change the communication protocol on the device. Please make sure to order the required model.

The devices can operate either as Modbus RTU RS485 slave device, or BACnet MS/TP Server. The device (slave/MAC) address and baud rate (limited) are set up using bit switches or through Windows Smart Configuration Tool / iOS Smart Phone App.

Bit switches 1-7 act as a binary decoder to set the (slave/MAC) address. Set these bit switches to OFF position if the address is configured by the software.

Bit switches 8 and 9 are used to set the baud rate. Set these bit switches to OFF position if the baud rate is configured by the software.

Bit switch EOL is used to activate 120 Ohm RS485 network End of Line termination (only used on the end of line devices).

NOTE: Default Modbus Baudrate is 9600, Parity None, 1 Stop Bit.

NOTE: Once bit switches are changed the device will automatically carry out soft reset to activate the new settings.

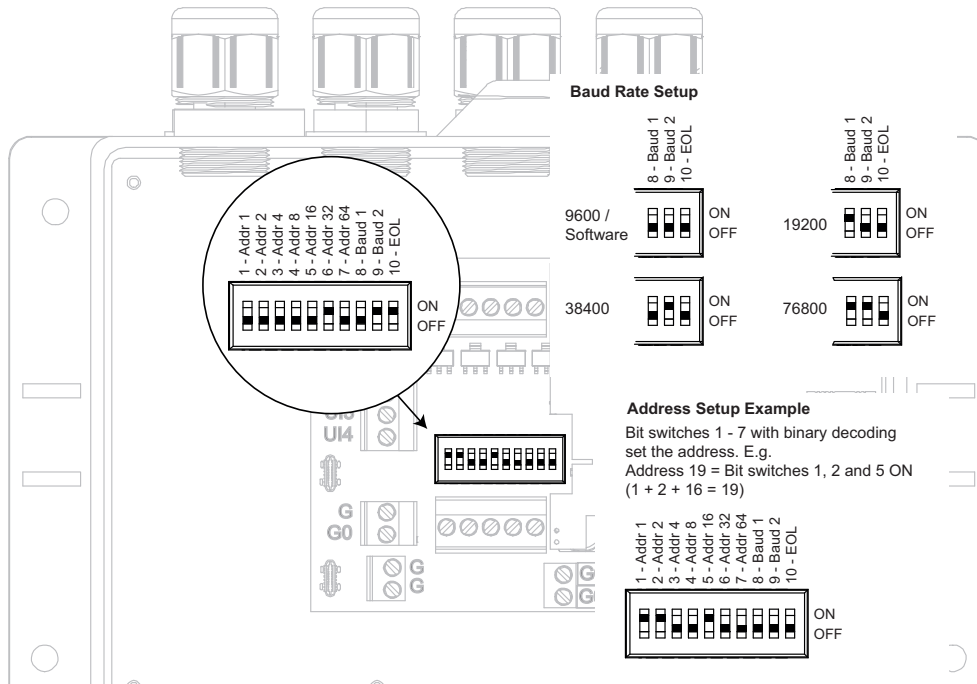

NOTE: Please note that Modbus register addresses start with 0 (0-based). If your Modbus master addresses start from one (1), then you will need to add one to the register values. If your Modbus master uses zero based addressing then the registers can be used as is.

NOTE: BACnet configuration parameter addresses are split to multiple instances of the Device Configuration object.

NOTE: Reg Field shows the Modbus register offset. The Reg field number is also the same with BACnet Device Configuration Objects.

LIVE DATA						
		MODBUS INPUT REGISTERS - FUNCTION CODE 04 MODBUS HOLDING REGISTER - FUNCTION CODES 03, (06), 16				
Parameter	Description	Reg	Type	Data Range (multiplier)	Value Range / Enumerations	R/W
ZONE MEASUREMENTS (FROM TDR20 AND QDR20 ROOM DISPLAY INTERFACES)						
Z1 Temperature	Displays current Zone 1 temperature measurement reading Note: Value depends on the temperature unit °C/°F selection	400	int16	-400..2480 (x10)	-40.0..120.0°C / -40.0..248.0°F	R
Z1 Humidity Sensor	Displays current Zone 1 humidity measurement reading	401	uint16	0..1000 (x10)	0..100%rH	R
Z1 CO2 Sensor	Displays current measurement Zone 1 CO2 reading	402	uint16	0..10,000 (x1)	0..10,000ppm	R
Z1 VOC Sensor	Display current Zone 1 VOC Index Value	403	uint16	0..500 (x1)	0..500 index	R
Z1 Dew Point	Dew Point Temperature for Zone 1	404	int16	-400..1200 (x10)	-40.0..120.0°C	R
Z2 Temperature	Displays current Zone 2 temperature measurement reading Note: Value depends on the temperature unit °C/°F selection	405	int16	-400..2480 (x10)	-40.0..120.0°C / -40.0..248.0°F	R
Z2 Humidity Sensor	Displays current Zone 2 humidity measurement reading	406	uint16	0..1000 (x10)	0..100%rH	R
Z2 CO2 Sensor	Displays current measurement Zone 2 CO2 reading	407	uint16	0..10,000 (x1)	0..10,000ppm	R
Z2 VOC Sensor	Display current Zone 2 VOC Index Value	408	uint16	0..500 (x1)	0..500 index	R
Z2 Dew Point	Dew Point Temperature for Zone 2	409	int16	-400..1200 (x10)	-40.0..120.0°C	R
TCR86 SERIES CONTROLLER PHYSICAL INPUTS						
Averaged Temperature	Average Temperature Calculated by the Average Function	460	int16	-400..2480 (x10)	NTC Mode: -40..120°	R
UI1	Universal Input 1 Measurement Note: Value depends on the temperature / mode selection	461	int16	-400..2480 (x10)	NTC Mode: -40..120° AI Mode: 0..100% = 0..10V	R
UI2	Universal Input 2 Measurement Note: Value depends on the temperature / mode selection	462	int16	-400..2480 (x10)	NTC Mode: -40..120° AI Mode: 0..100% = 0..10V	R
UI3	Universal Input 3 Measurement Note: Value depends on the temperature / mode selection	463	int16	-400..2480 (x10)	NTC Mode: -40..120° AI Mode: 0..100% = 0..10V	R
UI4	Universal Input 4 Measurement Note: Value depends on the temperature / mode selection	464	int16	-400..2480 (x10)	NTC Mode: -40..120° AI Mode: 0..100% = 0..10V	R
DI1	Digital Input 1 Status	200		0..1	0..1	R
DI2	Digital Input 2 Status	201		0..1	0..1	R
DI3	Digital Input 3 Status	202		0..1	0..1	R
DI4	Digital Input 4 Status	203		0..1	0..1	R
TCR86 SERIES CONTROLLER PHYSICAL OUTPUTS						
AO1	Analogue Output 1 Value	465	uint16	0..1000 (x10)	0..100% = 0..10V	R
AO2	Analogue Output 2 Value	466	uint16	0..1000 (x10)	0..100% = 0..10V	R
Relay 1 Status	Relay 1 Output Status	206		0..1	0..1	R
Relay 2 Status	Relay 2 Output Status	207		0..1	0..1	R
Relay 3 Status	Relay 3 Output Status	208		0..1	0..1	R
Relay 4 Status	Relay 4 Output Status	209		0..1	0..1	R
Relay 5 Status	Relay 5 Output Status	210		0..1	0..1	R
Relay 6 Status	Relay 6 Output Status	211		0..1	0..1	R
SETPOINT AND DEMANDS						
Calculated Multi-Stage Setpoint	Calculated Setpoint for Multi-Stage Control Loop (set via Nominal Setpoint or through TDR/QDR20)	420	int16	-32000..32000 (x10)	-3200.0..3200.0	R
Heating Demand	Heating Stage Demand (Multi-Loop Heating Stage 1/2/3)	421	int16	0..1000 (x10)	0..100%	R
Cooling Demand	Cooling Stage Demand (Multi-Loop Cooling Stage 1/2/3)	422	int16	0..1000 (x10)	0..100%	R
Current Control Mode	Current Control Mode Status	423	int16	0..2 (x1)	0 = Occupied 1 = Unoccupied 2 = Night	R

Cooling Status	Main Loop Cooling Stage Override Status	424	int16	0..3 (x1)	0 = Normal Operation 1 = Digital Input Disable (Condensation) 2 = Dew Point Disable (Condensation) 3 = Dehumidify (Cooling Stage 2 Overridden ON)	R
CO2 Loop Demand	CO2 Loop Demand	425	int16	0..1000 (x10)	0..100%	R
Humidity Loop Demand	Humidity Control Loop Demand	426	int16	0..1000 (x10)	0..100%	R
VOC Loop Demand	VOC Control Loop Demand	427	int16	0..1000 (x10)	0..100%	R
Fan Demand	Fan Loop Demand	428	int16	0..1000 (x10)	0..100%	R
Fan Mode	Current Fan Mode	429	int16	0..4 (x1)	0 = Off 1 = Manual Speed 1 2 = Manual Speed 2 3 = Manual Speed 3 4 = Auto	R

INPUT/OUTPUT SETTINGS						
Parameter	Description	Modbus Register / BACnet Property	MODBUS HOLDING REGISTER - FUNCTION CODES 03, 06, 16		Value Range / Enumerations	R/W
			Type	Data Range (multiplier)		
UNIVERSAL INPUTS						
UI1 Mode	Sets the Universal Input 1 Mode Note: Options 8,9,10 override to selected controller mode on OFF to ON transition. Note: Option 11 overrides to Occupied Mode on ON transition and Unoccupied Mode on OFF transition. Note: Option 12 overrides to Occupied Mode on ON transition and Off Mode on OFF transition. Note: When setting Universal Input to Digital modes, reset (apply changes) is required after the change to activate the correct state. Note: Properties 500-511 available in BACnet as Config Object properties 1150-1161	500 (BACnet 1150)	unit16	0..12 (x1)	0 = Not Used 1 = 0..10V (0..100%) 2 = NTC10 (Default) 3 = Dew Point (NTC10) 4 = Not Applicable 5 = Digital - Network 6 = Digital - Z1 Disable Cooling / Resistive Condensation Sensor 7 = Not Applicable 8 = Digital - Occupied 9 = Digital - Unoccupied 10 = Digital - Off 11 = Digital - Unocc/Occ 12 = Digital - Off / Occ	R/W
UI1 Voltage Min.	Sets Min. Clamp Voltage for UI1.	501 (1151)	unit16	0..100 (x10)	0..10.0 (Default 0)	R/W
UI1 Voltage Max.	Sets Max. Clamp Voltage for UI1. Use only if the connected device upper range is more than 3000.	502 (1152)	unit16	0..100 (x10)	0..10.0 (Default 10.0)	R/W
UI1 Scale Min.	Sets the scaling for Min. Measurement when UI1 @ 0V (0%)	503 (1153)	unit16	0..30000 (x10)	0.0..3000.0 (Default 0)	R/W
UI1 Scale Max.	Sets scaling for the Max. Measurement when UI1 @ 10V (100%)	504 (1154)	unit16	0..30000 (x10)	0.0..3000.0 (Default 100.0)	R/W
UI1 Temperature Offset	UI1 Temperature Single Point Sensor Calibration Offset Note: Only applies when UI Mode = NTC10	505 (1155)	int16	-100..100 (x10)	-10.0..+10.0deg (Default 0)	R/W
UI2 Mode	Sets the Universal Input 2 Mode.	506 (1156)	unit16	0..17 (x1)	See UI1 Mode for Enumerations	R/W
UI2 Voltage Min.	Sets Min. Clamp Voltage for UI2. Advanced Setting.	507 (1157)	unit16	0..100 (x10)	0..10.0 (Default 0)	R/W
UI2 Voltage Max.	Sets Max. Clamp Voltage for UI2. Use only if the connected device upper range is more than 3000.	508 (1158)	unit16	0..100 (x10)	0..10.0 (Default 10.0)	R/W
UI2 Scale Min.	Sets the scaling for Min. Measurement when UI2 @ 0V (0%)	509 (1159)	unit16	0..30000 (x10)	0.0..3000.0 (Default 0)	R/W
UI2 Scale Max.	Sets scaling for the Max. Measurement when UI2 @ 10V (100%)	510 (1160)	unit16	0..30000 (x10)	0.0..3000.0 (Default 100.0)	R/W

UI2 Temperature Offset	UI2 Temperature Single Point Sensor Calibration Offset	511 (1161)	int16	-100..100 (x10)	-10.0..+10.0deg (Default 0)	R/W
UI3 Mode	Sets the Universal Input 3 Mode.	512	unit16	0..17 (x1)	See UI1 Mode for Enumerations	R/W
UI3 Voltage Min.	Sets Min. Clamp Voltage for UI3.	513	unit16	0..100 (x10)	0..10.0 (Default 0)	R/W
UI3 Voltage Max.	Sets Max. Clamp Voltage for UI3. Use only if the connected device upper range is more than 3000.	514	unit16	0..100 (x10)	0..10.0 (Default 10.0)	R/W
UI3 Scale Min.	Sets the scaling for Min. Measurement when UI3 @ 0V (0%)	515	unit16	0..30000 (x10)	0.0..3000.0 (Default 0)	R/W
UI3 Scale Max.	Sets scaling for the Max. Measurement when UI3 @ 10V (100%)	516	unit16	0..30000 (x10)	0.0..3000.0 (Default 100.0)	R/W
UI3 Temperature Offset	UI3 Temperature Single Point Sensor Calibration Offset	517	int16	-100..100 (x10)	-10.0..+10.0deg (Default 0)	R/W
UI4 Mode	Sets the Universal Input 4 Mode.	518	unit16	0..17 (x1)	See UI1 Mode for Enumerations	R/W
UI4 Voltage Min.	Sets Min. Clamp Voltage for UI4. Advanced Setting.	519	unit16	0..100 (x10)	0..10.0 (Default 0)	R/W
UI4 Voltage Max.	Sets Max. Clamp Voltage for UI4. Use only if the connected device upper range is more than 3000.	520	unit16	0..100 (x10)	0..10.0 (Default 10.0)	R/W
UI4 Scale Min.	Sets the scaling for Min. Measurement when UI4 @ 0V (0%)	521	unit16	0..30000 (x10)	0.0..3000.0 (Default 0)	R/W
UI4 Scale Max.	Sets scaling for the Max. Measurement when UI4 @ 10V (100%)	522	unit16	0..30000 (x10)	0.0..3000.0 (Default 100.0)	R/W
UI4 Temperature Offset	UI4 Temperature Single Point Sensor Calibration Offset	523	int16	-100..100 (x10)	-10.0..+10.0deg (Default 0)	R/W
Temperature Units	Sets the temperature measurement and display to operate in Celcius or Fahrenheit. Note: To show Fahrenheit on display set the correct Unit setting on the display.	524	unit16	0..1 (x1)	0 = Celcius (Default) 1 = Fahrenheit	R/W

ANALOGUE OUTPUTS						
AO1 Mode	AO1 Output Configuration Default: Heating Stage 1 Note: For Modus to override the output from the network set the mode to network. Note: For BACnet the output can be overridden using corresponding AV objects.	530	unit16	0..29 (x1)	0 = Network Value 1 = Heating Stage 1 2 = Heating Stage 2 3 = Heating Stage 3 4 = Cooling Stage 1 5 = Cooling Stage 2 6 = Cooling Stage 3 7 = CO2 Demand 8 = VOC Demand 9 = Humidity/DeHum Demand 10 = Max Function 1 11 = Max Function 2 12 = Fan Demand 13 = 6-Way Valve 14 = Reverse 6-Way Valve 15 to 28 = Not Applicable 29 = Economizer	R/W
AO1 Override	Analogue Output AO1 Override Value	531	unit16	0..1000 (x10)	0.0..100.0% (Default 0)	R/W
AO1 Minimum	AO1 Output Minimum Level	532	unit16	0..1000 (x10)	0.0..100.0% (Default 0%)	R/W
AO1 Maximum	AO1 Output Maximum Level	533	unit16	0..1000 (x10)	0.0..100.0% (Default 100%)	R/W
AO2 Mode	AO2 Output Configuration Default: Economizer	534	unit16	0..28 (x1)	See AO Mode for Enumerations	R/W
AO2 Override	Analogue Output AO2 Override Value	535	unit16	0..1000 (x10)	0.0..100.0% (Default 0)	R/W
AO2 Minimum	AO2 Output Minimum Level	536	unit16	0..1000 (x10)	0.0..100.0% (Default 0%)	R/W
AO2 Maximum	AO2 Output Maximum Level	537	unit16	0..1000 (x10)	0.0..100.0% (Default 100%)	R/W
Sequence 1 Start Value (Sq1Start)	6-Way Valve Sequence 1 Start Voltage. With setting '6-Way Valve' Main Loop Heating Stage 1 at 0% Demand.	546	unit16	0..100 (x10)	0..100% (Default 47%)	R/W
Sequence 1 Stop Value (Sq1Stop)	6-Way Valve Sequence 1 Stop Voltage. With setting '6-Way Valve' Main Loop Heating Stage 1 at 100% Demand.	547	unit16	0..100 (x10)	0..100% (Default 20%)	R/W
Sequence 2 Start Value (Sq2Start)	6-Way Valve Sequence 2 Start Voltage. With setting '6-Way Valve' Main Loop Cooling Stage 1 at 0% Demand.	548	unit16	0..100 (x10)	0..100% (Default 73%)	R/W

Sequence 2 Stop Value (Sq2Stop)	6-Way Valve Sequence 2 Stop Voltage. With setting '6-Way Valve' Main Loop Cooling Stage 1 at 100% Demand.	549	uint16	0..100 (x10)	0..100% (Default 100%)	R/W
---------------------------------	-----------------------------------------------------------------------------------------------------------	-----	--------	--------------	------------------------	-----

DIGITAL INPUT SETTINGS

Digital Input 1 Off Delay	Delay Off Timer for the Universal Input 1 in Digital Input Mode	555	uint16	0..28,800 (x1)	0..28,800 seconds (default 0 secs)	R/W
Digital Input 1 Polarity	UI1 Digital Input Polarity Setting - allows the polarity of the input operation to be reversed when used in digital modes.	556	uint16	0..1 (x1)	0 = Normal (Default) 1 = Reverse	R/W
Digital Input 2 Off Delay	Delay Off Timer for the Universal Input 2 in Digital Input Mode	557	uint16	0..28,800 (x1)	0..28,800 seconds (default 0 secs)	R/W
Digital Input 2 Polarity	UI2 Digital Input Polarity Setting - allows the polarity of the input operation to be reversed when used in digital modes.	558	uint16	0..1 (x1)	0 = Normal (Default) 1 = Reverse	R/W
Digital Input 3 Off Delay	Delay Off Timer for the Universal Input 3 in Digital Input Mode	559	uint16	0..28,800 (x1)	0..28,800 seconds (default 0 secs)	R/W
Digital Input 3 Polarity	UI3 Digital Input Polarity Setting - allows the polarity of the input operation to be reversed when used in digital modes.	560	uint16	0..1 (x1)	0 = Normal (Default) 1 = Reverse	R/W
Digital Input 4 Off Delay	Delay Off Timer for the Universal Input 4 in Digital Input Mode	561	uint16	0..28,800 (x1)	0..28,800 seconds (default 0 secs)	R/W
Digital Input 4 Polarity	UI4 Digital Input Polarity Setting - allows the polarity of the input operation to be reversed when used in digital modes.	562	uint16	0..1 (x1)	0 = Normal (Default) 1 = Reverse	R/W

DIGITAL OUTPUT SETTINGS

DO1 Mode	Digital Relay Output 1 Configuration Default: Heating Stage 1	570	uint16	0..33 (x1)	0 = Network Value 1 = Heating Stage 1 2 = Heating Stage 2 3 = Heating Stage 3 4 = Cooling Stage 1 5 = Cooling Stage 2 6 = Cooling Stage 3 7 = CO2 Demand 8 = VOC Demand 9 = Humidity/DeHum Demand 10 = Max Function 1 11 = Max Function 2 12 = Fan Demand 13 = Fan Speed 1 14 = Fan Speed 2 15 = Fan Speed 3 16 to 30: Not Applicable 31 = None 32 = Cooling Active 33 = Heating Active	R/W
DO2 Mode	Digital Relay Output 2 Configuration Default: Heating Stage 2	571	uint16	0..33 (x1)		R/W
DO3 Mode	Digital Relay Output 3 Configuration Default: Fan Speed 1	572	uint16	0..33 (x1)		R/W
DO4 Mode	Digital Relay Output 4 Configuration Default: Cooling Active Note: With options 13-15, set Fan Mode = Stepped.	573	uint16	0..33 (x1)		R/W
DO5 Mode	Digital Relay Output 2 Configuration Default: Cooling Stage 1	591	uint16	0..33 (x1)		
DO6 Mode	Digital Relay Output 3 Configuration Default: Cooling Stage 2	592	uint16	0..33 (x1)		
DO1 Direction	Digital Output 1 Direction	577	uint16	0..1 (x1)	0 = Normal (Default) 1 = Reverse	R/W
DO2 Direction	Digital Output 2 Direction	578	uint16	0..1 (x1)	0 = Normal (Default) 1 = Reverse	R/W
DO3 Direction	Digital Output 3 Direction	579	uint16	0..1 (x1)	0 = Normal (Default) 1 = Reverse	R/W
DO4 Direction	Digital Output 4 Direction	580	uint16	0..1 (x1)	0 = Normal (Default) 1 = Reverse	R/W
DO5 Direction	Digital Output 5 Direction	593	uint16	0..1 (x1)	0 = Normal (Default) 1 = Reverse	R/W
DO6 Direction	Digital Output 6 Direction	594	uint16	0..1 (x1)	0 = Normal (Default) 1 = Reverse	R/W
DO ON Value	The value at Relay Output Switches ON	575	uint16	0..100 (x1)	0..100% (Default 50%)	R/W
DO OFF Value	The value at Relay Output Switches OFF	576	uint16	0..100 (x1)	0..100% (Default 0%)	R/W

DO1 Level Override	DO1 Network Override Note: Set output to Network	583	uint16	0..100 (x1)	0% = OFF (default) 100% = ON	R/W
DO2 Level Override	DO2 Network Override Note: Set output to Network	584	uint16	0..100 (x1)		R/W
DO3 Level Override	DO3 Network Override Note: Set output to Network	585	uint16	0..100 (x1)		R/W
DO4 Level Override	DO4 Network Override Note: Set output to Network	586	uint16	0..100 (x1)		R/W
DO5 Level Override	DO5 Network Override Note: Set output to Network	595	uint16	0..100 (x1)		R/W
DO6 Level Override	DO6 Network Override Note: Set output to Network	596	uint16	0..100 (x1)		R/W
DO1 Min Off Time	Digital Output 1 Min Off Time	630	unit16	0..255 (x1)	0..255 mins (Default 0)	R/W
DO2 Min Off Time	Digital Output 2 Min Off Time	631	unit16	0..255 (x1)	0..255 mins (Default 0)	R/W
DO3 Min Off Time	Digital Output 3 Min Off Time	632	unit16	0..255 (x1)	0..255 mins (Default 0)	R/W
DO4 Min Off Time	Digital Output 4 Min Off Time	633	unit16	0..255 (x1)	0..255 mins (Default 0)	R/W
DO5 Min Off Time	Digital Output 5 Min Off Time	634	unit16	0..255 (x1)	0..255 mins (Default 0)	R/W
DO6 Min Off Time	Digital Output 6 Min Off Time	635	unit16	0..255 (x1)	0..255 mins (Default 0)	R/W

NETWORK VALUES AND OUPUT EXERCISE						
Parameter	Description	Modbus Register / BACnet Property	MODBUS HOLDING REGISTER - FUNCTION CODES 03, 06, 16		Value Range / Enumerations	R/W
			Type	Data Range (multiplier)		
Network Value 1	Network Value 1. Used for control loop external measurements and TDR/QDR20 display functions. NOTE: This value is also automatically sent to Modbus Slave 1 Reg 538 if slave activated. TDR/QDR can display the value depending on configuration.	600	int16	-9990..9990 (x10)	-999.0..999.0 (Default 0)	R/W
Network Value 2	Network Value 2 (for displaying network integer value e.g. energy measurements) NOTE: This value is also automatically sent to Modbus Slave 1 Reg 539 if slave activated	601	uint16	0..65535 (x1)	0..65535 (Default 0)	R/W
Network Value 3	Network Value 1. Used for control loop external measurements and display functions. NOTE: This value is also automatically sent to Modbus Slave 2 Reg 538 if slave activated	602	int16	-9990..9990 (x10)	-999.0..999.0 (Default 0)	R/W
Network Value 4	Network Value 2 (for displaying network integer value e.g. energy measurements) NOTE: This value is also automatically sent to Modbus Slave 2 Reg 539 if slave activated	604	uint16	0..65535 (x1)	0..65535 (Default 0)	R/W
Valve Exercise Period	Sets the period of inactivity to activate the corresponding output.	610	uint16	0..15 (x1)	0..15 days (Default 14 days)	R/W
AO1 Exercise Time	Analogue Output 1 Exercise Time. After configured period of inactivity, the output is driven to 50% for the Y1 Exercise Time	611	uint16	0..15 (x1)	0..15 Minutes (Default: 0) 0 = Disabled	R/W
AO2 Exercise Time	Analogue Output 2 Exercise Time. After configured period of inactivity, the output is driven to 50% for the Y2 Exercise Time	612	uint16	0..15 (x1)	0..15 Minutes (Default: 0) 0 = Disabled	R/W
AO2 Exercise Time	Analogue Output 3 Exercise Time. After configured period of inactivity, the output is driven to 50% for the Y3 Exercise Time	613	uint16	0..15 (x1)	0..15 Minutes (Default: 0) 0 = Disabled	R/W
AO2 Exercise Time	Analogue Output 4 Exercise Time. After configured period of inactivity, the output is driven to 50% for the Y4 Exercise Time	614	uint16	0..15 (x1)	0..15 Minutes (Default: 0) 0 = Disabled	R/W

AVERAGE FUNCTION						
Parameter	Description	Modbus Register / BACnet Property	MODBUS HOLDING REGISTER - FUNCTION CODES 03, 06, 16		Value Range / Enumerations	R/W
			Type	Data Range (multiplier)		
Measurement 1	Measurement 1 for Average Calculation	620	uint16	0..6 (x1)	0 = Disabled (Default) 1 = UI1 2 = UI2 3 = UI3 4 = UI4 5 = Z1 Temperature 6 = Z2 Temperature	R/W
Measurement 2	Measurement 2 for Average Calculation	621	uint16	0..6 (x1)		R/W
Measurement 3	Measurement 3 for Average Calculation	622	uint16	0..6 (x1)		R/W
Measurement 4	Measurement 4 for Average Calculation NOTE: Options 1-4 use Register 460-463 values allowing averaging to be done both NTC10 and voltage	623	uint16	0..6 (x1)		R/W

CONTROL SETTINGS						
Parameter	Description	Modbus Register / BACnet Property	MODBUS HOLDING REGISTER - FUNCTION CODES 03, 06, 16		Value Range / Enumerations	R/W
			Type	Data Range (multiplier)		
CONTROL MODES AND OVERRIDES						
Override Control Mode	Override Current Control Mode (last transition applies e.g. if overridden from BACnet/Modbus network the user can change through the TDR/QDR20 Display - network poll)	681	uint16	0..3 (x1)	0 = Occupied 1 = Unoccupied 2 = Night 3 = No Override (Default)	R/W
MULTI-STAGE CONTROL LOOP						
Loop Source	Sets the Control Source for the Multi-Stage Control Loop. Note: If UI mode is NTC, the control value is as measured. If the UI mode is 0-10V, then 0..10V is scaled to measurement according to UI Input Min/Max scaling parameters. Note: Average value is the calculation from Average Function.	700	uint16	0..10 (x1)	0 = Network Value (Reg 600) 1 = Zone Sensor 1 Temperature (Default) 2 = UI1 - NTC10 3 = UI2 - NTC10 4 = UI3 - NTC10 5 = UI4 - NTC10 6 = UI1 - 0..10Vdc 7 = UI2 - 0..10Vdc 8 = UI3 - 0..10Vdc 9 = UI4 - 0..10Vdc 10 = Average Value	R/W
Nominal Setpoint	Control Loop Nominal Setpoint Note: The control loop setpoint can be shifted by the high/low limit (cascade) control function.	701	uint16	0..2120 (x10)	0.0..212.0, Default 70.0	R/W
Proportional Band	Control Loop Proportional Band (for each Stage)	705	uint16	1..500 (x1)	1..500 (Default 5)	R/W
Integral Action Time	Control Loop Integral Action Time (Set to 0 to disable)	706	uint16	0..3600 (x1)	0..3600s (Default 600s) 0 = Disabled	R/W
No of Heating Stages	Sets the number of heating stages.	707	uint16	0..3 (x1)	0 = None 1 = 1-Stage	R/W
No of Cooling Stages	Sets the number of cooling stages.	708	uint16	0..3 (x1)	2 = 2-Stages (Default) 3 = 3-Stages	R/W
Occ Heating Deadzone	Occupied Mode Heating Deadzone.	709	uint16	0..300 (x10)	0.0..30.0 (Default 0.5)	R/W
Occ Cooling Deadzone	Occupied Mode Cooling Deadzone.	710	uint16	0..300 (x10)	0.0..30.0 (Default 0.5)	R/W
Unocc Heating Deadzone	Unoccupied Mode Heating Deadzone.	711	uint16	0..300 (x10)	0.0..30.0 (Default 5.0)	R/W
Unocc Cooling Deadzone	Unoccupied Mode Cooling Deadzone.	712	uint16	0..300 (x10)	0.0..30.0 (Default 5.0)	R/W
Frost Setpoint	Off Mode Frost Setpoint.	713	uint16	0..600 (x10)	0.0..60.0 (Default 50.0)	R/W

CHANGE-OVER FUNCTION						
Change-Over Source	Sets the Source for the Change-Over Function Note: As default the Network Command is Off i.e. no change-over function is active.	722	uint16	0..8 (x1)	0 = Network Command (Reg 726, Default) 1 = UI1 - NTC10 2 = UI2 - NTC10 3 = UI3 - NTC10 4 = UI4 - NTC10 5 = Digital Input 1 (UI1) 6 = Digital Input 2 (UI2) 7 = Digital Input 3 (UI3) 8 = Digital Input 4 (UI4)	R/W
Change-Over Low Level	Temperature below which the change-over is active (cooling stage active). Note: Relevant only for NTC Input 1/2/3/4 options.	724	uint16	0..1000 (x10)	0..100.0° Default 65°	R/W
Change-Over High Level	Temperature above which the change-over is off (heating stage active, no override on control). Note: Relevant only for NTC Input 1/2/3/4 options.	725	uint16	0..1000 (x10)	0..100.0° Default 72°	R/W
Change-Over Override	Heating / Cooling Mode Command from Network. Note: Requires change-over source to be set as Network.	726	uint16	0..1 (x1)	0 = Heating (Default) 1 = Cooling	R/W

LOW/HIGH LIMIT RESET FUNCTION						
Reset Control Source	Sets the Temperature Source for the Reset Control Function. Note: Default: 5 - Disabled	727	uint16	0..5 (x1)	0 = Network Value (Reg 600) 1 = UI1 - NTC10 2 = UI2 - NTC10 3 = UI3 - NTC10 4 = UI4 - NTC10 5 = Disable (Default)	R/W
High Limit Setpoint	High Limit Setpoint. Above this limit the setpoint is reduced proportionally according to the ratio and temperature difference.	729	uint16	0..1000 (x10)	0.0..100.0° Default 95°	R/W
Low Limit Setpoint	Low Limit Setpoint. Below this limit the setpoint is increased proportionally according to the ratio and temperature difference.	730	uint16	0..1000 (x10)	0.0..100.0° Default 59°	R/W
Reset Ratio	Reset ratio used to calculated the setpoint reset.	731	uint16	0..100 (x10)	0.0..10.0 (Default 1.0)	R/W

MAX FUNCTION						
Max1 Source 1	Sets the Souce for Input 1 of Maximum Function 1 Default: Heating Stage 1	732	uint16	0..12 (x1)	0 = Network Value (Reg 600)	R/W
Max1 Source 2	Sets the Souce for Input 2 of Maximum Function 1 Default: Cooling Stage 1	733	uint16	0..12 (x1)	1 = Heating Stage 1 2 = Heating Stage 2 3 = Heating Stage 3	R/W
Max2 Source 1	Sets the Souce for Input 1 of Maximum Function 2 Default: Cooling Stage 1	734	uint16	0..12 (x1)	4 = Cooling Stage 1 5 = Cooling Stage 2	R/W
Max2 Source 2	Sets the Souce for Input 2 of Maximum Function 2 Default: CO2 Demand	735	uint16	0..12 (x1)	6 = Cooling Stage 3 7 = CO2 Demand 8 = VOC Demand 9 = Humidity/DeHum Demand 10 = Max Function 1 11 = Max Function 2 12 = Fan Demand	R/W

FAN CONTROL						
Fan Control Source	Sets the Temperature Source for the Fan Control Function.	740	uint16	0..11 (x1)	0 = Network Value (Reg 600) 1 = Heating Stage 1 2 = Heating Stage 2 3 = Heating Stage 3 4 = Cooling Stage 1 5 = Cooling Stage 2 6 = Cooling Stage 3 7 = CO2 Demand 8 = VOC Demand 9 = Humidity/DeHum Demand 10 = Max Function 1 (Default) 11 = Max Function 2	R/W
Min Fan Speed	Sets the Minimum Fan Speed for EC Fans	741	uint16	0..100 (x1)	0..100% (Default 15%)	R/W
Fan Speed 1	Sets the Fan Speed 1 for EC Fans (when source 33%)	742	uint16	0..100 (x1)	0..100% (Default 33%)	R/W
Fan Speed 2	Sets the Fan Speed 2 for EC Fans (when source 66%)	743	uint16	0..100 (x1)	0..100% (Default 66%)	R/W
Fan Speed 3	Sets the Fan Speed 3 for EC Fans (when source 99%)	744	uint16	0..100 (x1)	0..100% (Default 100%)	R/W

Fan Mode	Sets the EC Fan Mode. Continuous Mode scales the fan demand based on the source and Fan Speed 1/2/3 settings. In Stepped mode the fan speed steps according to Fan Speed 1/2/3 settings.	745	uint16	0..1 (x1)	0 = Continuous Mode 1 = Stepped Mode (Default)	R/W
Fan Off Mode	Configures if the Fan is running at minimum level or is off when the fan control demand is at 0%.	746	uint16	0..1 (x1)	0 = Off (Default) 1 = Minimum Speed	R/W
Fan Off Delay	Switch OFF delay when the source demand drops to 0 (and Fan Off Mode is set to Off).	747	uint16	0..600 (x1)	0..600 seconds (Default 0)	R/W
Fan Start-Up Delay	Fan Start-Up when the source demand increases above 0%. During the delay the fan runs at Fan Speed 1 setting.	748	uint16	0..600 (x1)	0..600 seconds (Default 10)	R/W
Fan Level Override	Current Fan Level that can be set from the network. The override value is also automatically sent to the corresponding Room Display Interface.	749	uint16	0..5	0 = Manual Off 1 = Level 1 2 = Level 2 3 = Level 3 4 = Automatic 5 = No Override	R/W
Fan Levels	Z1 Fan Levels	750	uint16	0..2	0 = 0-1-A (Default) 1 = 0-1-2-A 2 = 0-1-2-3-A	R/W
Max Auto Fan Speed	Maximum Fan Speed in Automatic Control Mode	752	uint16	0..100 (x1)	0..100% (Default 100%)	R/W

AIR QUALITY CONTROL

CO2 Control Source	Sets the Source for the CO2 Control. Zone CO2 Measurement is from Room Display Interface 1 (Modbus Slave 1, Reg 402) Note: If set to UI1/UI2/UI3/UI4, then 0..10V is scaled to measurement according to UI Input Min/Max scaling parameters.	760	uint16	0..5 (x1)	0 = Network Value (Reg 601) 1 = Zone Sensor 1 CO2 Measurement (Default) 2 = UI1 - 0..10V 3 = UI2 - 0..10V 4 = UI3 - 0..10V 5 = UI4 - 0..10V	R/W
CO2 Setpoint	CO2 Control Setpoint	761	uint16	0..10000 (x1)	0..10,000 (Default 750)	R/W
CO2 Proportional Band	CO2 Control Proportional Band	762	uint16	1..10000 (x1)	1..10,000 (Default 500)	R/W
CO2 Integral Action Time	CO2 Control Integral Action Time (Set to 0 to disable)	763	uint16	0..3600 (x1)	0..3600s (Default 0s)	R/W
VOC Control Source	Sets the Source for the VOC Control. Zone VOC Measurement is from Room Display Interface 1 (Modbus Slave 1, Reg 402)	770	uint16	0..1 (x1)	0 = Network Value (Reg 601) 1 = Zone Sensor 1 VOC Measurement (Default)	R/W
VOC Setpoint	VOC Control Setpoint	771	uint16	0..500 (x1)	0..500 (Default 100)	R/W
VOC Proportional Band	VOC Control Proportional Band	772	uint16	1..500 (x1)	1..500 (Default 100)	R/W
VOC Integral Action	VOC Control Integral Action Time (Set to 0 to disable)	773	uint16	0..3600 (x1)	0..3600s (Default 0s)	R/W

ZONE 1 HUMIDITY CONTROL

Humidity Source	Sets the Source for the Humidity Control. Zone Humidity Measurement is from Room Display Interface 1. Note: If set to UI1/UI2/UI3/UI4, then 0..10V is scaled to measurement according to UI Input Min/Max scaling parameters	780	uint16	0..5 (x1)	0 = Network Value (Reg 600) 1 = Zone Sensor 1 Humidity Measurement (Default) 2 = UI1 - 0..10V 3 = UI2 - 0..10V 4 = UI3 - 0..10V 5 = UI4 - 0..10V	R/W
Humidity Setpoint	Humidity Control Loop Setpoint	781	uint16	0..100 (x1)	0..100% (Default 50%)	R/W
Humidity Proportional Band	Humidity Control Proportional Band	782	uint16	1..100 (x1)	1..100% (Default 20)	R/W
Humidity Integral Action	Humidity Control Integral Action Time (Set to 0 to disable)	783	uint16	0..3600 (x1)	0..3600s (Default 0s)	R/W
Humidity Mode	Humidity Loop Control Mode Default: Humidify (Reverse)	784	uint16	0..1 (x1)	0 = Humidify (Reverse) 1 = De-Humidify (Direct)	R/W
Humidity Interlock	Enables Cooling Stage 2 Interlock on High Humidity	785	uint16	0..1 (x1)	0 = Disabled (Default) 1 = Enabled	R/W
Dew Point Range	Dew Point calculation range where the Dew Point based cooling max. position calculates linearly from 100% to 0%	786	uint16	0..10 (x1)	0..10 Degrees (Default 4)	R/W

Dew Point Mode	Dew Point Mode Selection	787	uint16	0..1 (x1)	0 = On-Off 1 = Proportional (Default)	R/W
Dew Point Offset	Dew Point Offset (from the calculated Dew Point) where the Dew Point based calculated max. position is 0%	788	uint16	0..50 (x10)	0..5.0 Degrees (Default 1.0)	R/W

ECONOMIZER AND DISCHARGE LOW TEMP CONTROL, COMPRESSOR AND HEATING3 LOCKOUT FUNCTIONS						
Ecomiser Source	Sets the Economizer Control Source (typically Cooling Stage 1)	790	uint16	0..2 (x1)	0 = Cooling1 (Default) 1 = Cooling2 2 = Cooling3	R/W
Economizer Limit Temp Source	Temperature that the Economizer function is monitoring (typically outside air temperature sensor).	791	uint16	0..4 (x1)	0 = None (Default) 1 = UI1-NTC10 2 = UI2-NTC10 3 = UI3-NTC10 4 = UI4-NTC10	R/W
Economizer Limit Temp	Temperature Limit for the Economizer Output to Modulate	792	uint16	0..2120.0 (x10)	0..212.0 (Default 60.0)	R/W
Economizer Min. Output	Minimum Output Level for the Economizer (min. damper position)	793	uint16	0..1000.0 (x10)	0..1000 (Default 15)	R/W
Discharge Temp Source	Discharge Temperature to be monitored	794	uint16	0..4 (x1)	0 = None (Default) 1 = UI1-NTC10 2 = UI2-NTC10 3 = UI3-NTC10 4 = UI4-NTC10	R/W
Discharge Min Temp	Min. Temperature Limit for Discharge Temperature	795	uint16	0..2120.0 (x10)	0..212.0 (Default 60.0)	R/W
Discharge Limit Band	Discharge Limit Band (to modulate the Economizer output to min. position)	796	uint16	0..500.0 (x10)	0..50.0 (Default 2.0)	R/W
Compressor Lockout Enable	Compressor Lockout (Heating Stage 1 and 2) Enable	775	uint16	0..1 (x1)	0 = Disabled (Default) 1 = Enabled	R/W
Compressor OAT Low Limit	Temperature Limit to Switch Heating Stages 1 and 2 to 0%	776	uint16	0..2120.0 (x10)	0..212.0 (Default 25)	R/W
Htg3 Lockout Enable	Heating Stage 3 Lockout Enable	777	uint16	0..1 (x1)	0 = Disabled (Default) 1 = Enabled	R/W
Htg3 Lockout Temp	Temperature Limit to Switch Heating Stage 3 to 0%	778	uint16	0..2120.0 (x10)	0..212.0 (Default 60.0)	R/W

SYSTEM AND COMMUNICATION SETTINGS					
Parameter	Description	Modbus Register / BACnet Property	MODBUS HOLDING REGISTER - FUNCTION CODES 03, 06, 16		Value Range / Enumerations
			Type	Data Range (multiplier)	
Address	Modbus Address BACnet MAC Address	800	uint16	1..247 (x1) 1..127 (x1)	Modbus: 1..247 BACnet: 1..127
Baud Rate	Baud Rate	801	uint16	0..5	0 = 9600 1 = 19200 2 = 38400 3 = 57600 4 = 76800 5 = 115200
Modbus Parity	Modbus Parity	802	uint16	0..2	0 = None 1 = Odd 2 = Even
Modbus Stopbits	Modbus Stopbits	803	uint16	0..1	0 = 1 Stop Bit 1 = 2 Stop Bits
Soft Reset	Soft Reset	810	uint16	0..1	0 = Normal 1 = Reset
Persist	Persist (Store Parameters in Non-Volatile Memory)	811	uint16	0..1	0 = Normal 1 = Persist
Factory Defaults	Reload Defaults (NOTE: Resets all settings to factory defaults)	812	uint16	0..1	0 = Normal 1 = Factory Defaults

Service Pin	Service Pin (BACnet Only)	813	uint16	0..1	0 = Normal 1 = Service Pin
Zone 1 Sensor	Enables Zone 1 TDR20/QDR20 Sensor (Modbus Address 1)	814	uint16	0..1	0 = Disabled 1 = Enabled (Default)
Zone 2 Sensor	Enables Zone 2 TDR20/QDR20 Sensor (Modbus Address 2)	815	uint16	0..1	0 = Disabled (Default) 1 = Enabled
Zones Lock Override	Overrides the Zone Sensor Lock (both Zone 1 and Zone 1 - TDR20/QDR20)	608	uint16	0..2	0 = No Override 1 = Unlock Screen 2 = Lock Screen
Firmware Version	Firmware Version	820	uint16	N/A	N/A
Serial Number	Serial Number	821	uint16	N/A	N/A
Date Code	Date Code	822	uint16	N/A	N/A
Product ID	Product ID	823	uint16	N/A	N/A
Device ID	BACnet Device ID. Set to 0 to use Automatically generated ID. Follow change with "Persist" and "Reset".	825	uint32	0..4,194,303 (x1)	0..4,194,303

The following registers are available with Modbus only. The registers combine two parameters to a single 16-bit (2 Bytes) Modbus register.

MODBUS SPECIFIC COMBINATION REGISTERS						
Parameter	Description		MODBUS INPUT REGISTERS - FUNCTION CODE 04 MODBUS HOLDING REGISTER - FUNCTION CODES 03, 16			
			Type	Data Range (multiplier)	Value Range / Enumerations	R/W
AO1/AO2	Combined 16-Bit Register for Outputs AO1 and AO2. E.g. AO1=0x64 (100%), AO2=0x64 (100%) Register=0x6464 (25700)	450	unit16	0..25700 (x1) 0x0000..0x6464	Byte 1:Y1 (0x00..0x64), Byte 2:Y2 (0x00..0x64)	R
Htg/Clg	Combined 16-Bit Register for Heating and Cooling Demands	452	unit16	0..25700 (x1) 0x0000..0x6464	Byte 1: Htg (0x00..0x64), Byte 2: Clg (0x00..0x64)	R
Device Status	Combined 16-Bit Register for Binary Status of the Device	455	unit16	0..25700 (x1)	Bit0 - DI1, Bit1 = DI2, Bit3 = PIR, Bit4 = Relay, Bit5= Boost, Bit6 = Screen Lock	R

Bacnet Protocol Implementation Statement (PICS) and BACnet Objects

The -BAC versions of the controllers come with BACnet MS/TP communication. The following tables describe the PICS (Protocol Implementation Conformance Statement) and BACnet Objects (Standard and Proprietary). The Proprietary Objects are used for the device configuration.

GENERAL INFORMATION	
Date:	Mar 1, 2024
Vendor Name:	Senticon Ltd
Vendor ID:	1374
Product Name:	xCR Smart Room Controller
Product Models:	TCRxx, QCRxx
Applications Software Version:	1.0
Firmware Revision:	1.0.0
BACnet Prorocol Revision	1.19
Product Description:	Smart Room Controller
BACnet Standard Device Profile:	BACnet Application Specific Controller (B-ASC)
BACnet Interoperability Blocks Supported:	Data Sharing - ReadProperty-B (DS-RP-B) Data Sharing - ReadPropertyMultiple-B (DS-RPM-B) Data Sharing - WriteProperty-B (DS-WP-B) Data Sharing - COV-B (DS-COVU-B) Device Management - DynamicDeviceBinding-B (DM-DDB-B) Device Management - DynamicObjectBinding-B (DM-DOB-B) Device Management - DeviceCommunicationControl-B (DM-DCC-B)
Segmentation Capability:	No
Data Link Layer Options:	MS/TP Master; Supported Baud 9600/19200/38400/57600/76800/115200
Device Address Binding:	No static device binding supported
Networking Options:	None

Character Sets Supported:	ISO 10646 (UTF-8)		
Gateway Options:	None		
Network Security Options:	Non-Secure Device		
Standard Object Types Supported:	Object Type:	Optional Properties	Writeable Properties
	Analog Value:	Description, COV Increment, Relinquish Default	Present Value COV Increment
	Binary Value:	Description, Inactive_Text, Active_Text	Present Value
	Device Object:	Description Active COV Subscriptions Max Master	Object Identifier Object Name APDU Timeout (0...60000) Number Of APDU Retries (0...10) Max Master (1...127)
<p><i>For all supported objects, device does not support CreateObject or DeleteObject.</i></p> <p><i>For Analog Value objects that are classified as read only, there is the following behavior:</i></p> <ul style="list-style-type: none"> - HVAC application overwrites the present value that has been written with the Write Property Service. - In this case, no error message will be sent. <p><i>The device application checks the ranges of the Present Value and the COV Increment of the Analog Objects. For this reason, there is the following behavior:</i></p> <ul style="list-style-type: none"> - No error message, if the limits have been exceeded - Too high values are set to the range maximum - Too small values are set to the range minimum 			

OBJECT TYPE: DEVICE OBJECT				
Object Instance	Property Identifier	Value Range	Default Value	R/W
Device[x]	Object Identifier		MAC_Address	R/W
	Object Name	32 chars max.	TCR82_XXX	R/W
	Object_Type		8	R
	System_Status		Status_Operational	R
	Vendor_Name		Senticon Ltd	R
	Vendor_Identifier		1374	R
	Model_Name		TCR81 / TCR82	R
	Firmware_Revision		1.0.0	R
	Application_Software_Version		1.0	R
	Protocol_Version		1	R
	Protocol_Revision		19	R
	Protocol_Services_Supported		See General Information	R
	Protocol_Object_Types_Supporte		See General Information	R
	Object_List		See Objects List	R
	Max_APDU_Length_Accepted		480	R
	Segmentation_Supported		No	R
	APDU_Timeout		6000 ms	R/W
	Number_Of_APDU_Retries		3	R/W
	Max_Master		127	R/W
	Device_Address_Binding			R
Database_Revision		0	R	
Property_List			R	

OBJECT TYPE: ANALOGUE VALUE						
Object Instance	Object Name	Value Range	Relinquish_Default	Units	COV Increment	R/W
AV(0)	UI1	-40.0..120.0°C / -40..248°F 0..100.0%	-	DEGREES_CELCIUS or DEGREES_FAHRENHEIT or NO_UNITS	0.0..100 Default 1.0*	R
AV(1)	UI2	-40.0..120.0°C / -40..248°F 0..100.0%	-	DEGREES_CELCIUS or DEGREES_FAHRENHEIT or NO_UNITS	0.0..100 Default 1.0*	R
AV(2)	UI3	-40.0..120.0°C / -40..248°F 0..100.0%	-	DEGREES_CELCIUS or DEGREES_FAHRENHEIT or NO_UNITS	0.0..100 Default 1.0*	R
AV(3)	UI3	-40.0..120.0°C / -40..248°F 0..100.0%	-	DEGREES_CELCIUS or DEGREES_FAHRENHEIT or NO_UNITS	0.0..100 Default 1.0*	R
AV(4)	Z1 Temperature	-40.0..120.0°C / -40.0..248.0°F	-	DEGREES_CELCIUS or DEGREES_FAHRENHEIT	0.0..100 (Default 0.5*)	R
AV(5)	Z1 Humidity	0..100.0	-	RELATIVE_HUMIDITY	0.0..100 (Default 5*)	R
AV(6)	Z1 CO2	0..10,000	-	PARTS_PER_MILLION	0.0..100 (Default 50*)	R
AV(7)	Z1 VOC	0..1,000	-	NO_UNITS	0.0..100 (Default 10*)	R
AV(8)	Z2 Temperature	-40.0..120.0°C / -40.0..248.0°F	-	DEGREES_CELCIUS or DEGREES_FAHRENHEIT	0.0..100 (Default 0.5*)	R
AV(9)	Z2 Humidity	0..100.0	-	RELATIVE_HUMIDITY	0.0..100 (Default 5*)	R
AV(10)	Z2 CO2	0..10,000	-	PARTS_PER_MILLION	0.0..100 (Default 50*)	R
AV(11)	Z2 VOC	0..1,000	-	NO_UNITS	0.0..100 (Default 10*)	R
AV(12)	Z1_Setpoint_Temp	0.0..212.0	Nonvol_Setpoint	NO_UNITS	n/a	R/W
AV(13)	Z1_Setpoint_Humidity	0..100.0	Nonvol_Setpoint	RELATIVE_HUMIDITY	n/a	R/W
AV(14)	Z1_Fan_Speed	0..4.0	Nonvol_FanSpeed	NO_UNITS	1	R/W
AV(15)	Z1_Occupancy_Mode (Occupied/Unocc/Off)	0..2.0	Nonvol_OpMode	NO_UNITS	1	R/W
AV(16)	Z2_Setpoint_Temp	0.0..212.0	Nonvol_Setpoint	NO_UNITS	n/a	R/W
AV(17)	Z2_Setpoint_Humidity	0..100.0	Nonvol_Setpoint	RELATIVE_HUMIDITY	n/a	R/W
AV(18)	Z2_Fan_Speed	0..4.0	Nonvol_FanSpeed	NO_UNITS	1	R/W
AV(19)	Z2_Occupancy_Mode (Occupied/Unocc/Off)	0..2.0	Nonvol_OpMode	NO_UNITS	1	R/W
AV(20)	Network_Decimal_1	-999.0..999.0	Nonvol_Setpoint	NO_UNITS	n/a	R/W
AV(21)	Network_Integer_1	0..65535.0	Nonvol_Setpoint	NO_UNITS	n/a	R/W
AV(22)	Network_Decimal_2	-999.0..999.0	Nonvol_Setpoint	NO_UNITS	n/a	R/W
AV(23)	Network_Integer_2	0..65535.0	Nonvol_Setpoint	NO_UNITS	n/a	R/W
AV(24)	Y1	0.0..100.0%	-	PERCENT	5	R/W
AV(25)	Y2	0.0..100.0%	-	PERCENT	5	R/W
AV(26)	Y3 - Not Applicable	0.0..100.0%	-	PERCENT	5	R/W
AV(27)	Y4 - Not Applicable	0.0..100.0%	-	PERCENT	5	R/W
AV(28)	Not Applicable					
AV(29)	Not Applicable					
AV(30)	Not Applicable					
AV(31)	Not Applicable					

NOTE: Priority Input 16 is reserved for internal value. If COV increment is set to 0.0 (default), the COV is disabled.

NOTE: AV14/AV15/AV16/AV17 override the controller and TDR/QDR20 interface. To allow changes from the TDR20/QDR20, set the Priority Inputs to 'null' after the override.

NOTE: R = Read Only, R/W = Read/Write

NOTE: On COV Increments marked with asterisk (*), the COV Increment changes are stored in non volatile memory after applying 'Persist'.

OBJECT TYPE: BINARY VALUE					
Object Instance	Object Name	Description	Present Value Range / Active - Inactive Tex	Relinquish_Default	R/W
BV(0)	DI_1	Digital Input 1 Status	0: InActive (Off) 1: Active (On)	Binary_Inactive	R
BV(1)	DI_2	Digital Input 2 Status	0: InActive (Off) 1: Active (On)	Binary_Inactive	R
BV(2)	DI_3	Digital Input 1 Status	0: InActive (Off) 1: Active (On)	Binary_Inactive	R
BV(3)	DI_4	Digital Input 2 Status	0: InActive (Off) 1: Active (On)	Binary_Inactive	R
BV(4)	Z1_Cooling_Mode	Cooling Mode Override for Heating Stage 1 (Heating/Cooling)	0: InActive (Heating) 1: Active (Cooling)	Binary_Inactive	R/W
BV(5)	Not Applicable				

PROPRIETARY OBJECT	
OBJECT NAME / TYPE: "CONFIGx" / 128	
The devices have six instances of proprietary Device Configuration objects split as with the configuration tools; Cfg_Inputs, Cfg_Outputs, Cfg_Calibration, Cfg_Display, Cfg_Control_1, Cfg_Control_2, Cfg_System. The devices can be fully configured using the properties of these configuration obejcts. Full list of available properties are listed in the <i>Device Setup and Modbus/BACnet Communication</i> section tables.	

In addition to the generic parameters, the BACnet AV and BV objects have proprietary property to enable COV (Unsubscribed COV) function. For the AV objcts the COV increment can be changed from the defaults. For the BV objects data is transmitted when the state changes.

NOTE: Enabling COV increases network load as the messages are broadcasted to all devices. For efficient network performance limit the number of COV objects to minimal and configure routers to allow broadcasts only on the subnets.

BACNET COV OBJECT SETTINGS						
Parameter	Description	BACnet Property	Type	Data Range (multiplier)	Value Range / Enumerations	R/W
AVx COV	AV Object COV Enable Flag x = AV Object Number (AV0..AV11, AV14..AV15, A18..AV19)	100x	uint16	0..1(x1)	0 = COV Disabled 1 = COV Enabled	R/W
BVx COV	BV Object COV Enable Flag x = BV Object Number (BV0..BV3)	110x	uint16	0..1(x1)	0 = COV Disabled 1 = COV Enabled	R/W

Dimensions

DIMENSIONS

