

## TCR02/QCR02/TCR03/QCR03 Slimline and TCR04/QCR04 Series Room Controllers



The xCR02/xCR03/xCR04 Series Controllers and Slimline controllers have been designed to be wall mounted temperature and air quality controllers in room spaces. The controllers are suitable for a wide range of applications and have pre-defined application logic that covers most room control heating and cooling systems such as fan coil units, chilled ceilings, zone heating etc.

The room controllers have colour LCD screen indicating the current measurement and controller operating status. The user can adjust the setpoint and fan speed through the push buttons. The controllers are mounted on the wall surface directly or to standard wall mounting boxes. The SlimLine range is mounted using the wall boxes. The controllers have built-in Modbus RTU or BACnet MS/TP communication that allow interaction to the BMS systems.

### Features

- Advanced Room Controllers for wide variety of room control applications.
- Multi-Stage PI Control and CO2 Loop provide accurate control of Temperature and CO2 or combination of them with high/low limit, summer/winter change-over maximum demand etc. functions
- Modbus RS485 RTU or BACnet MS/TP with up to 60V industrial isolation on RS485 for system integration
- Colour LCD for displaying the controller status and adjusting the fan speed, operating mode or operate boost
- 2 push buttons for setpoint
- 1 push button for fan speed adjustment (standard 3 Button models)
- 1 push button for operating mode adjustment (3 Button OM-models)
- 1 push button for boost function (3 Button BST-models)
- QCR02, QCR03 and QCR04 Series have Built-in CO2 Measurement and Control
- 2x Universal inputs (temperature/0-10V/digital) offer application flexibility
- xCR02 and xCR04: 3 x Analogue 0..10Vdc Outputs, max 2mA, 2 x 24Vac Triac Outputs
- xCR03: 1 x Analogue 0..10Vdc Outputs, max 2mA, 2 x 24Vac Triac Outputs, 3 x 230Vac 5A Relays
- Optional PIR Occupancy Sensor with 2 Button Models

- Configuration wirelessly through Device Configuration Tool Windows Software (wireless Bluetooth/wired/Modbus connection) or Smart Phone iOS App (using Bluetooth Dongle).

## Technical Specifications

<b>Power Supply:</b>	Power:	24Vac/dc -10%/+15%, max 40mA with display
<b>Measurements:</b>	Temperature (All Models)	
	Range:	0..50° (32..122°F)
	Accuracy:	+/-0.5°C
	CO2 (QCR Models)	
	Range:	0..10,000ppm
	Accuracy:	+/-50ppm + 5% of the reading
	PIR Movement (Option)	
	Type/Range:	Passive Infrared Movement Detection, Range up to 5m
<b>Inputs:</b>	Universal Inputs:	2 x Universal Inputs - RI/AI/DI Application Selected RI = NTC10 Measurement / Resistive AI = 0..10Vdc Input DI = Digital Volt-Free Input
<b>Outputs:</b>	Analogue Outputs:	xCR02/xCR04: 3 x 0..10Vdc, min. load resistance >5 kOhms (max. 2mA @ 10V) xCR03: 1 x 0..10Vdc, min. load resistance >5 kOhms (max. 2mA @ 10V)
	Digital Outputs:	All Models: 2 x 24Vac Rated Triacs, Switching to 0V, Max 1A load (for thermic actuators)
	Relay Outputs:	xCR03: 3 x 230Vac, max 5A (res.)
<b>Communication:</b>	Physical Interface	1 x RS485 driver with up to 60V industrial Isolation, recommended max 63 devices
	Protocol:	Modbus RTU or BACnet MS/TP
	Addressing:	Via Bitswitch: 1..127 (xCR04 Range Only) Via Software/Display: 1..247 for Modbus, 1..127 for BACnet MS/TP
	Settings:	Baud Rate: 9600/19200/38400/76800 (bitswitch), 57600/115200 (software) Modbus Parity: None/Even/Odd, Modbus Stop Bits: 1 or 2 (Default: 9600/None/1)
<b>Display:</b>	LCD	Colour LCD Display with Overlay
<b>User Adjustment:</b>	Buttons:	2B models: 2 Push Buttons (setpoint up and down) 3B models: Fan Speed (standard model), Operating Mode (OM models), Boost (BST models)
<b>Mechanical:</b>	Wiring Terminals:	Rising Cage Screw Terminals, 0.2 to 2.5mm <sup>2</sup> / 26 to 12 AWG
	Enclosure:	ABS ULV0 Plastics - White or Black
	Protection Class:	IP30 (when mounted on a wall or a junction box)
	Mounting:	Standard: Wall or Junction Box Mounting (60mm screw distance) Slimline: Junction Box Mounting (60mm screw distance)
	Dimensions	Standard: W86 x H86 x D24mm Slimline: W86 x H86 x D14mm (Surface Part) W86 x H86 x D39mm (Total)
<b>Country of Origin:</b>		United Kingdom

## Model Selection

Refer to the below table to select the required model. The part number offers descriptive method for the product and options selection, and the SKU# number provides unique reference number. It is possible to order products using either.

Part Number		SKU# Number				
Example	TCR04-MOD-LCD-3B-W	4000	1	23	00	00 02
<b>Product Name</b>		Product	Product Options			
TCR02	Slimline Room Temperature Controller, 2UI, 3AO, 2DO	4200				
QCR02	Slimline Room Temperature and CO2 Controller, 2UI, 3AO, 2DO	4300				
TCR03	Slimline Room Temperature Controller, 2UI, 2DO, 3RO, 1AO	4400				
QCR03	Slimline Room Temperature and CO2 Controller, 2UI, 2DO, 3RO, 1AO	4500				
TCR04	Room Temperature Controller, 2UI, 3AO, 2DO	4000				
QCR04	Room Temperature and CO2 Controller, 2UI, 3AO, 2DO	4100				
<b>Serial Communication Option</b>						
MOD	Modbus RS485		1			
BAC	BACnet MS/TP		2			
<b>Interface Options</b>						
LCD-2B	Colour LCD Display with Two Buttons			22		
LCD-3B	Colour LCD Display with Three Buttons			23		
LCD-3B-BST	Colour LCD Display with Three Buttons, Setpoint Up and Down, Boost Button			33		
LCD-3B-OM	Colour LCD Display with Three Buttons, Setpoint Up and Down, Operating Mode Button			43		
<b>Measurement Options</b>						
	No Extra Measurements				00	
OE	Passive Infrared Movement (PIR) - Only Available with LCD-2B Models				03	
<b>Colour Options</b>						
W	White				00	02

## Wiring Connections

### STANDARD TCR04/QCR04 SURFACE MODELS WIRING

The diagram below illustrates the wiring connections to the controllers.

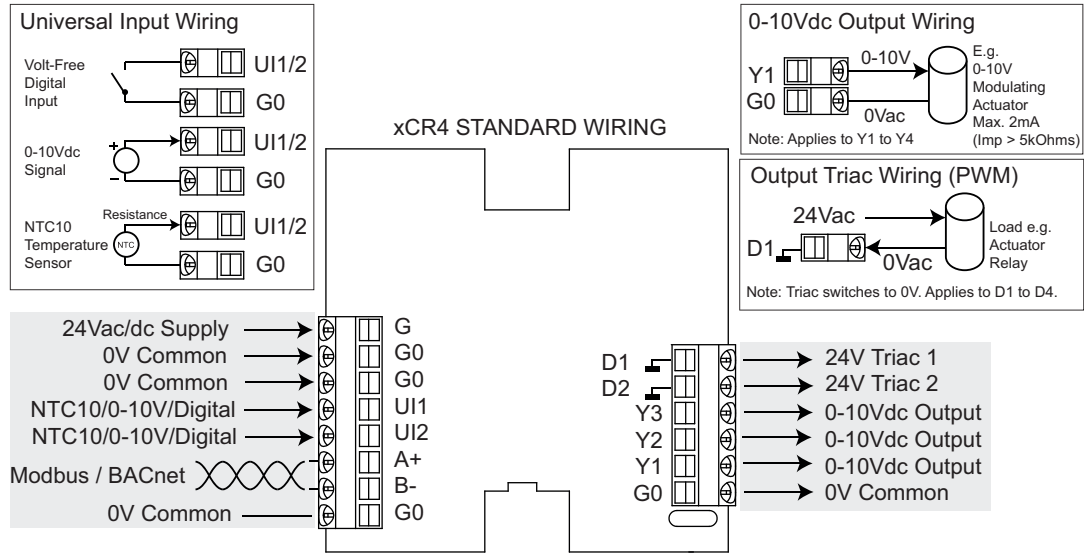

### WIRING TERMINATIONS

Terminal	Description
G	24Vac/dc -10/+15% Supply
G0	0V Common
UI1	NTC10/0-10V/Volt-Free Digital Input 1
UI2	NTC10/0-10V/Volt-Free Digital Input 2
A+	Modbus / BACnet RS485 A+
B-	Modbus / BACnet RS485 B-
G0	0V Common

Terminal	Description
D1	24Vac Triac, Max 1A
D2	24Vac Triac, Max 1A
Y3	0-10Vdc Output max. 2mA
Y2	0-10Vdc Output max. 2mA
Y1	0-10Vdc Output max. 2mA
G0	0V Common

**SLIMLINE RANGE TCR02/QCR02 WIRING**

Slimline range (xCR02) controllers are flush mounted to junction box. The diagrams below illustrate the wiring.

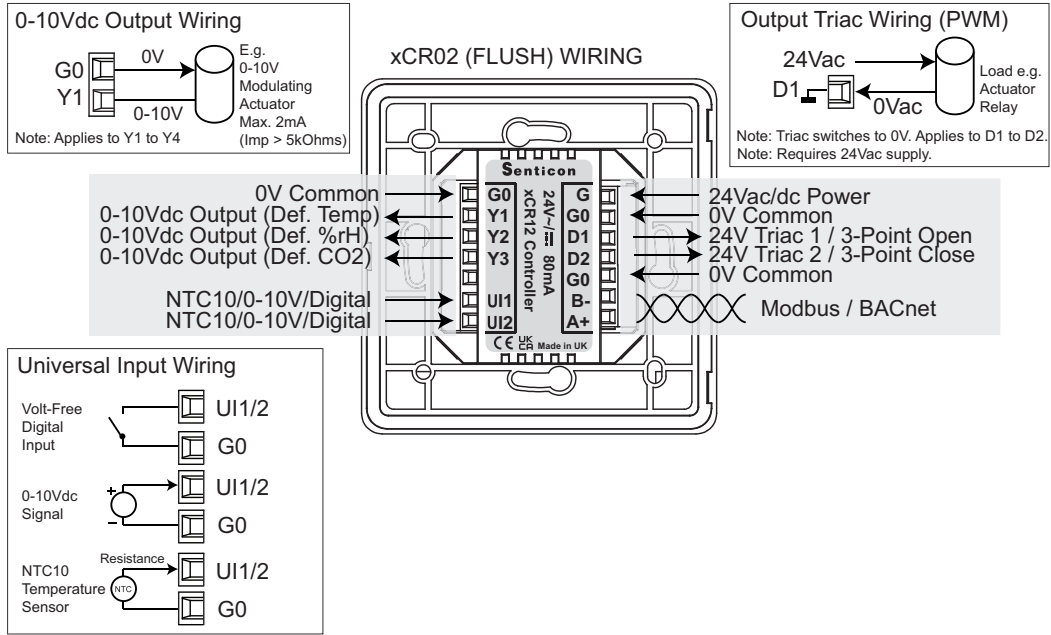

**WIRING TERMINATIONS**

Terminal	Description
G	24Vac/dc -10/+15% Supply
Y1	0-10Vdc Output max. 2mA
Y2	0-10Vdc Output max. 2mA
Y3	0-10Vdc Output max. 2mA
UI1	NTC10/0-10V/Volt-Free Digital Input 1
UI2	NTC10/0-10V/Volt-Free Digital Input 2

Terminal	Description
G	24Vac/dc -10/+15% Supply
G	24Vac/dc -10/+15% Supply
D1	24Vac Triac, Max 1A
D2	24Vac Triac, Max 1A
G0	0V Common
B-	Modbus / BACnet RS485 B-
A+	Modbus / BACnet RS485 A+

**SLIMLINE RANGE TCR03/QCR03 WIRING**

Slimline range (xCR03) controllers are flush mounted to junction box. The diagrams below illustrate the wiring.

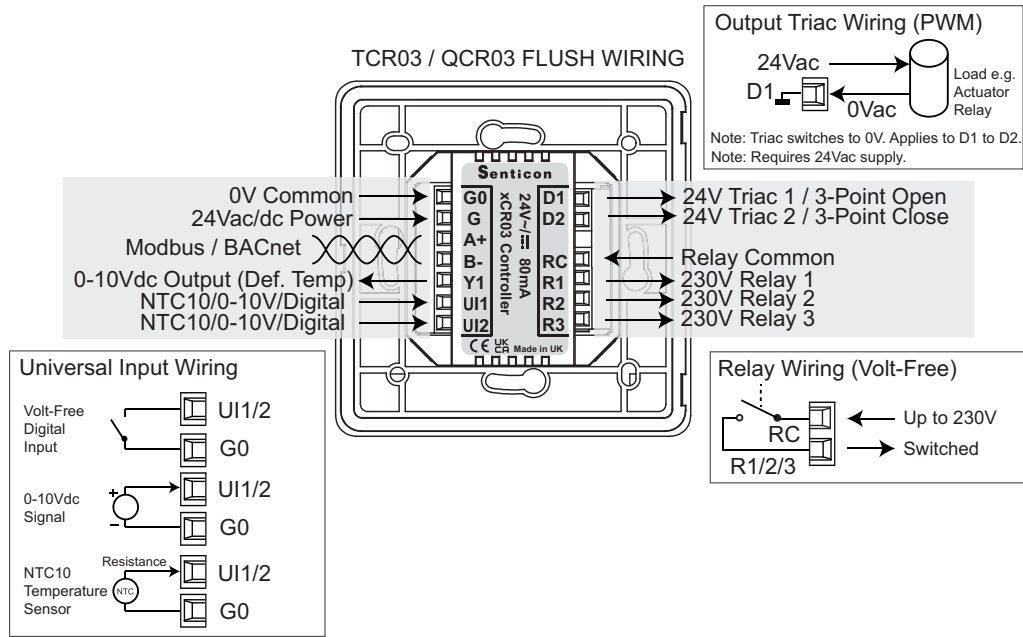

**WIRING TERMINATIONS**

Terminal	Description
G0	0V Common
Y1	0-10Vdc Output 1, max. 2mA (Default: Heating Stage 1)
Y2	0-10Vdc Output 2, max. 2mA (Default: Cooling Stage 1)
Y3	0-10Vdc Output 3, max. 2mA (Default: EC Fan Speed)
Y4	0-10Vdc Output 4, max. 2mA (Default: CO2 Control)
UI1	NTC10/0-10V/Volt-Free Digital Input 1
UI2	NTC10/0-10V/Volt-Free Digital Input 2

Terminal	Description
G	24Vac/dc -10/+15% Supply Note: Triacs need 24Vac
G0	0V Common
D1 RL	24Vac Triac, Max 1A 24V Relay (RL-option)
D2 RC	24Vac Triac, Max 1A 24V Relay Common (RL-option)
G0	0V Common
B-	Modbus / BACnet RS485 B-
A+	Modbus / BACnet RS485 A+

**WIRING GUIDELINES**

In order to wire the device, remove the front cover by pressing the clip on the bottom of the display e.g. using a flat headed screwdriver. Be careful not to use excess force. Whilst pressing the clip lift the front cover from the bottom edges of the enclosure.

Make sure that power is switched off and carry out wiring according to the wiring connections drawing and local wiring guidelines. Insert the front cover and power up the device.

**NOTE: For opening and mounting the enclosure please refer to the Dimensions and Installation Chapter.**

## Controller Applications

The TCR/QCR4 controllers have flexible software design that allows them to be tailored to typical room control applications. Each controller can be configured from default settings using the Smart Configuration tools or via the network. The unused inputs and outputs are available for Building Management Systems for additional control functions.

## Control Functions

### CONTROL MODES

The controllers have three control modes:-

- Occupied (Comfort)
- Unoccupied (Relaxed)
- Off (Night)

The controller operating mode is changed via hardware inputs or via Modbus/BACnet network. On transition from Occupied to Unoccupied/Off modes the Multi-Stage Loop user setpoint adjustments can be automatically reset to nominal values (enable *Reset User Adjustment* parameter)

NOTE: The control mode change happens when the controller sees the transition on the state of the command signal. This means that e.g if Digital Input 1 (U1) overrides the controller to unoccupied mode, the mode can be changed e.g. via network regardless of the current DI1 state.

The control loop outputs (demand signals) are set in different modes as per the below table.

Control Mode	Heating and Cooling Stages 1/2/3 Demand	Air Quality CO2 Control Demand	Fan Demand
Occupied	Based on control loop with occupied deadzone settings	Based on control loop	Based on control loop
Unoccupied	Based on control loop with unoccupied deadzone settings	Based on control loop	Based on control loop
Off	0% (Frost logic enables heating stages to 100%)	0%	0%

NOTE: On power up the controller starts in Occupied (Comfort) mode.

### MULTI-STAGE TEMPERATURE CONTROL

The controllers have multi-stage temperature control logic that meets requirements for advanced temperature control applications using PI-control (Proportional + Integral). Up to two (2) heating and up to two (2) cooling stages are available. Between the heating and cooling stages is a dead-zone where the heating and cooling outputs modulate to closed position providing energy savings in the building when the temperature reaches the setpoint. The heating and cooling deadzones can be separately set to provide asymmetrical control for increased energy savings.

The temperature control is operating in Occupied (comfort) / Unoccupied and Off modes. In unoccupied mode the temperature control is relaxed by increasing the heating and cooling deadzones. In the Off mode the temperature control is switched off (with frost protection active).

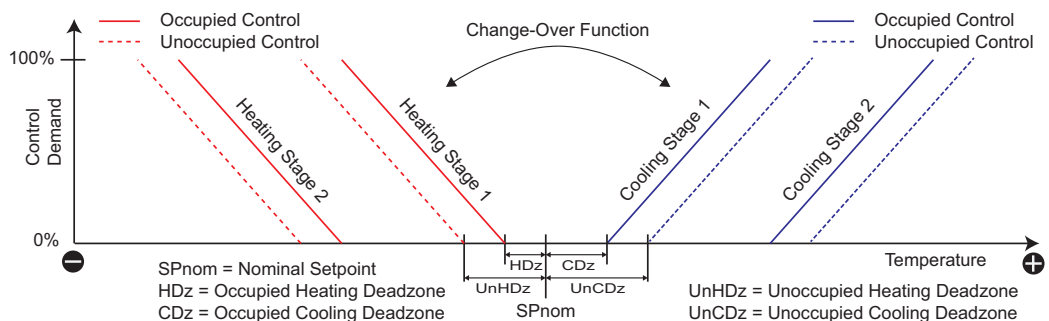

The multi-stage temperature control loop can be configured to control built-in temperature, Universal Input 1 temperature/voltage, Universal Input 2 Temperature/voltage, or network value (network temperature).

The loop controls to the Calculated Setpoint. The calculated setpoint uses the following formula:-

$$SP_{calc} = SP_{nom} + User\_Adjustment + Reset\_Function\_Adjustment$$

NOTE: Network value can only be used in systems where the measurement changes slowly.

## FROST PROTECTION (OFF MODE)

In the Night Off mode, the controller automatically monitors the control sensor for low temperature protection (Frost Setpoint). If temperature drops below the frost setpoint, the heating stages are switched on to 100% until temperature rises 2° above the Frost Setpoint

Parameter	Description	Value Range / Enumerations
Main Loop Source	Sets the Control Source for the Multi-Stage Control Loop.  Note: If UI mode is NTC, the control value is as measured temperature. If the UI mode is 0-10V, then 0..10V is scaled to measurement according to UI Input Min/Max scaling parameters 523-526.	0 = Network Value (Reg 538) 1 = Temperature (Built-In, Default) 2 = UI1 - NTC10 3 = UI2 - NTC10 4 = UI1 - 0..10Vdc 5 = UI2 - 0..10Vdc
Main Loop Nominal Setpoint (SPnom)	Main Control Loop Nominal Setpoint	0.0..212.0 (Default 21.0)
Main Setpoint Resolution	Main Setpoint Adjustment Resolution	0.1..10.0 (Default 0.1)
Min Adjustment	User Setpoint Adjustment Min Limit	-30.0..0.0 (Default -3.0)
Max Adjustment	User Setpoint Adjustment Max Limit	0..30.0 (Default 3.0)
Main Loop PB	Main Control Loop Proportional Band (for each stage)	1..500 (Default 5)
Main IA	Main Control Loop Integral Action Time (Set to 0 to disable)	0..3600s (Default 600s)
No of Heating Stages	Sets the number of heating stages.	0 = None 1 = 1-Stage (Default) 2 = 2-Stages
No of Cooling Stages	Sets the number of cooling stages.	0 = None 1 = 1-Stage (Default) 2 = 2-Stages
Occupied Heating Deadzone (HDz)	Occupied Mode Heating Deadzone	0.0..30.0 (Default 0.5)
Occupied Cooling Deadzone (CDz)	Occupied Mode Cooling Deadzone	0.0..30.0 (Default 0.5)
Unoccupied Heating Deadzone (UnHDz)	Unoccupied Mode Heating Deadzone	0.0..30.0 (Default 3.0)
Unoccupied Cooling Deadzone (UnCDz)	Unoccupied Mode Cooling Deadzone	0.0..30.0 (Default 3.0)
Frost Setpoint	Off Mode Frost Setpoint	0.0..60.0 (Default 10.0)

NOTE: If Change-Over function is activated, it can override the Heating Stage1 to operate as Cooling Stage1.

NOTE: Proportional Band is for each stage. E.g. if 2-stages of heating had been selected, and if the Proportional Band has been set as 5, then the Proportional Band across 2-stages of heating is 10.

### **CHANGE-OVER FUNCTION**

The controller can have a change-over function that reverses the multi-stage temperature control loop Heating Stage1 (and Cooling Stage1) operation.

The change-over function is activated by the digital input (UI1/UI2 digital input), via temperature (UI1/UI2 NTC10 temperature), or via network. If temperature is selected, the change-over is active (cooling mode is active) if temperature drops below the change-over low temperature until temperature reaches the change-over high temperature (heating mode becomes active).

Parameter	Description	Value Range / Enumerations
Change-Over Source	Sets the Source for the Change-Over Function.  Note: As default the Network Command is Off i.e. no change-over function is active. Note: When using Digital Inputs set the corresponding universal input mode to '4 - Network'.	0 = Network Command (Reg 721, Default) 1 = UI1 - NTC10 2 = UI2 - NTC10 3 = Digital Input 1 (UI1) 4 = Digital Input 2 (UI2)
Change-Over Target	Target of the Change-Over Control.	0 = None (Default) 1 = Multi-Stage Control Loop
Change-Over Low Temperature	Temperature below which the change-over is active (cooling stage active). Note: Relevant only for NTC Input 1/2 options.	0..100.0° (32..212°F) Default 18°C

Change-Over High Temperature	Temperature above which the change-over is off (heating stage active, no override on control). Note: Relevant only for NTC Input 1/2 options.	0..100.0° (32..212°F) Default 22°C
Network Change-Over Override	Heating / Cooling Mode Command from Network. Note: Requires change-over source to be set as Network.	0 = Heating (Default) 1 = Cooling

NOTE: Change-over function is not active in Off Mode.

NOTE: Typically configure the control output (Y1 to Y3) to Heating Stage1. In normal operation the output provides heating control (i.e. when temperature is below setpoint, there is heating demand). When the change-over is active, the same output provides cooling control (i.e. when temperature is above setpoint, there is cooling demand).

**EC FAN AND 3-SPEED FAN CONTROL**

Fan control logic is used to control EC fans and 3-Speed fans. Fan control logic can follow Continuous or Stepped control. In Continuous control when the source (e.g. heating and cooling demand) increases the fan speed increases linearly between speed settings.

When under automatic control if the input demand is less than the minimum level (*Min Fan Speed*) the output will be held at the minimum level. The only exception to this is when the *Fan Off Mode* is set to Off and the input demand is 0% in which case the output will be 0%

In stepped mode the Fan Speed is set in steps (for EC Fans or 3-Speed Fans) with 5% switching OFF hysteresis.

When the fan control source activates (increases above 0%) the Fan Speed is switched to '*Fan Speed 1*' Level for adjustable delay time ('*Fan Startup Delay*') regardless of the *Min Fan Speed* setting. This allows EC Fans to start to run properly before resuming normal control.

If the *Fan Off Mode* setting is set to Off, the Fan output switches OFF after an adjustable '*Fan Off Delay*' Time.

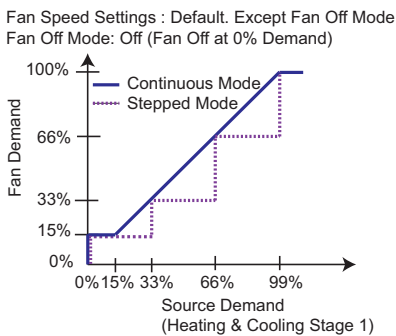
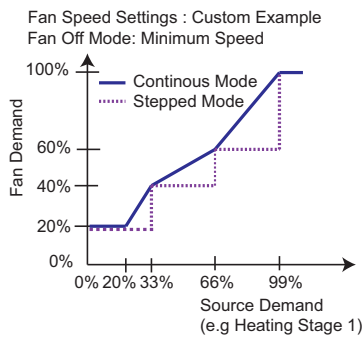
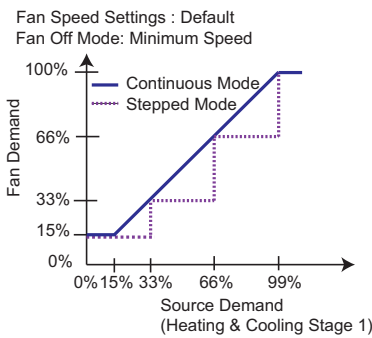

Parameter	Description	Value Range / Enumerations
Fan Control Source	Sets the Source Demand for the Fan Control Function. Note: Options 7&8 available from Fw1.21	0 = Network Value (Reg 538) 1 = Heating Stage 1 2 = Heating Stage 2 3 = Cooling Stage 1 4 = Cooling Stage 2 5 = CO2 Demand 6 = Htg/Clg Stage 1 (Default) 7 = Htg1/Clg2 8 = Htg2/Clg1
Min Fan Speed	Sets the Minimum Fan Speed for EC Fans	0..100% (Default 15%)
Fan Speed 1	Sets the Fan Speed 1 for EC Fans (when source 33%)	0..100% (Default 33%)
Fan Speed 2	Sets the Fan Speed 2 for EC Fans (when source 66%)	0..100% (Default 66%)
Fan Speed 3	Sets the Fan Speed 3 for EC Fans (when source 99%)	0..100% (Default 100%)

Fan Mode	Sets the EC Fan Mode. Continuous Mode scales the fan demand based on the source and Fan Speed 1/2/3 settings. In Stepped mode the fan speed steps according to Fan Speed 1/2/3 settings. In stepped mode the Fan Speed switching hysteresis is 5%.	0 = Continuous Mode (Default) 1 = Stepped Mode
Fan Off Mode	Configures if the Fan is running at minimum level or is off when the fan control demand is at 0%. 1 - Minimum Speed: Running at Minimum Speed at Occupied and UnOccupied (0% in OFF mode). 2 - Minimum Occupied: Running at Min Speed in Occupied Only	0 = Off (Default) 1 = Minimum Speed 2 = Minimum Occupied
Fan Off Delay	Switch OFF delay when the source demand drops to 0 (and Fan Off Mode is set to Off)	0..600 seconds (Default 0)
Fan Startup Delay	Fan Startup when the source demand increases above 0%. During the delay the fan runs at Fan Speed 1 setting.	0..600 seconds (Default 10)
Fan Level Override	Current Fan Level that can be set from the buttons or network (last command prevails). Note: If Fan Levels = 0-1-A, options 2, 3 and 4 override to Automatic control. Note: If Fan Levels = 0-1-2-A, then Level 2 overrides to Speed 3. Both 3 and 4 override to Automatic control	0 = Off 1 = Level 1 2 = Level 2 3 = Level 3 4 = Automatic
Fan Levels	Sets the available Fan Override levels for the fan button and the Fan Network Override	0 = 0-1-A 1 = 0-1-2-A 2 = 0-1-2-3-A (Default)
Fan Relay Delay	Delay between Fan Level Relays switching on the xCR03 Controllers (from Fw1.19)	0..30s (0s default)
Max Auto Fan Speed	Maximum Fan Speed in Automatic Control Mode (from Fw 1.12)	0..100% (Default 100%)

**3-SPEED FAN RELAY CONTROL (xCR03 MODELS)**

xCR03 models are equipped with 3 x 230Vac relays that are as default configured as 3-speed fan control (under *Relay Output Settings*). These outputs are controlled as ON/OFF based on the *740: Fan Control Source* demand. *FanSpeed1* is ON when source > Fan Speed 1 Level, *FanSpeed2* when source > Fan Speed Level 2 and *FanSpeed3* when source > Fan Speed Level 3. Hysteresis of 5% applies.

Parameter *751: Fan Relay Delay* can be used to delay each relay ON switching 0..30seconds (default 0s).

NOTE: To activate stepped fan control set *745: Fan Mode = Stepped*.

**MANUAL FAN SPEED CONTROL (STANDARD 3B MODELS)**

The fan speed manual override buttons set the Fan speed as per Fan Speed 1, 2, 3 and auto settings (see *Fan Speed Adjustment* section under User Interface chapter for details). In order for the controller to return back to automatic control the user needs to select Automatic mode in the button rotation. The display indicates the current fan speed.

The controller fan output level can also be override from the network by using the *Fan Override Level* parameter.

The available levels for manual and network control are set by the *Fan Levels* configuration parameter.

NOTE: In case of 0-1-2-A configuration if the user selects manual fan speed 2, the controller also uses Fan Speed 3 setting.

**CO2 (CARBON DIOXIDE) CONTROL**

QCR controllers have built-in CO2 measurement and control functionality. The CO2 measurement is typically used to boost the ventilation in case of higher concentration. The QCR provides CO2 control using PI (Proportional + Integral) control logic. The control loop output can be connected to the physical outputs to e.g. control the fresh air damper using analogue outputs.

With Proportional Control when the CO2 measurement increases above the *CO2 Setpoint*, the CO2 control demand (and control output) increases proportionally based on the Proportional Band (PB) setting - see image.

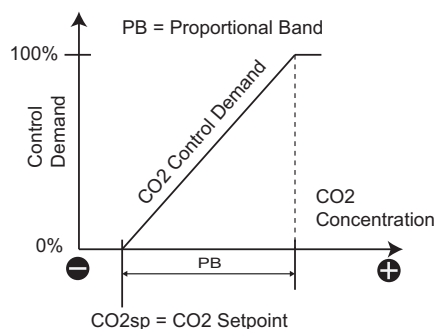

Often fresh air damper is also used to provide cool air to the building. In this case the damper is linked to both Cooling Stage temperature control and CO2 control. This can be achieved using so called 'Maximum VAV' logic (set output to *Maximum VAV*).

To set the minimum output position for the damper, the *Min Analogue Output* settings can be used. The *CO2 Setpoint Setback Parameter (764)* allows the CO2 Setpoint to be increased in the Unoccupied mode for the amount set in the parameter 764. For example, the CO2 setpoint can be changed from 750 (default) in Occupied mode to 1000 in the Unoccupied mode by setting *CO2 Setpoint Setback Parameter (764)* to 250 (ppm).

The CO2 measurement can be displayed on the screen and the measurement is available via Modbus and BACnet communication network (please refer to Touchscreen and Modbus/BACnet Communications sections for further details).

The CO2 sensor provides Automatic Self Calibration logic keeping measurement accurate over the time. The Automatic calibration can be disabled and the sensor can be manually calibrated (see Calibration Settings).

Parameter	Description	Value Range / Enumerations
CO2 Control Source	Sets the Source for the CO2 Control  Note: If set to UI1/UI2, then 0..10V is scaled to measurement according to UI Input Min/Max scaling parameters 523-526.	0 = Network Value (Reg 539) 1 = Built-In CO2 (Default) 2 = UI1 - 0..10V 3 = UI2 - 0..10V
CO2 Setpoint	CO2 Control Setpoint	0..10,000 (Default 750)
CO2 PB	CO2 Control Proportional Band	1..10,000 (Default 500)
CO2 IA	CO2 Control Integral Action Time (Set to 0 to disable)	0..3600s (Default 0s)
CO2 Setpoint Setback	CO2 Control Setpoint SetBack in Unoccupied mode	0..2,000 (Default 0)

**CONDENSATION CONTROL**

CONDENSATION SENSOR INPUTS

In cooling systems (e.g. chilled beam) when the pipe surface temperature drops reaching the dew point, this creates a condensation risk. The xCR controller have protection logic to minimise the condensation. This can be activated by enabling 'Digital Cooling Disable' on the Universal Inputs. In this mode the universal input operates as volt-free digital input. When the input closes the controller switches the multi-stage control loop Cooling Stage Demands to 0% until the volt-free input is off (open contact).

Alternative method is to use resistive condensation sensors where the resistance drops when condensation occurs, and resistance increases when the sensor is dry. To activate this function set the Universal Input mode to 'Digital Cooling Disable'. When resistance drops approximately below 100kOhms the condensation risk is active and when the resistance increases above approx. 150kOhms, there is no condensation risk. In case of condensation risk the multi-stage Cooling Stage Outputs are set to 0%

**MOVEMENT DETECTION AND CONTROL (OE OPTION)**

The controllers with Setpoint buttons (2B models) can be fitted with an optional pyroelectric infrared motion sensor for the movement and occupancy detection. The sensor element is designed for optimal usability and reliability with low power consumption, better sensitivity and signal-to-noise ratio reducing the false detections. The diagram illustrates the detection area.

In Standard mode when the controller detects Occupancy it switches to Occupied Mode. The *PIR Delay Off Timer* (10..28,800 seconds) parameter sets the time that the status latches ON after detection of movement.

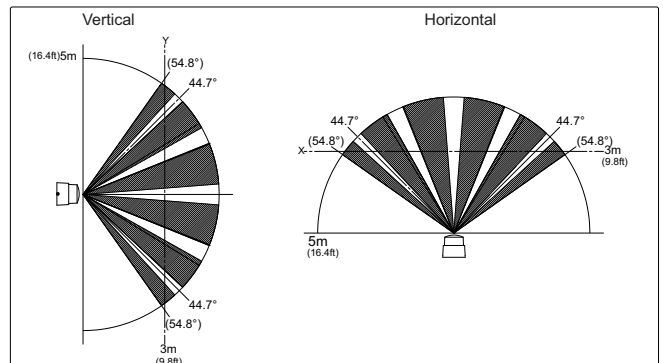

Once the timer has counted down the PIR status switches Off and the Controller Mode is switched to Unoccupied mode or Off mode depending on the configuration below.

NOTE: The PIR movement sensor has 30s warm-up time on reset.

NOTE: If the controller mode is overridden via the display or network, this mode is active until *PIR Delay Off Timer* resets.

NOTE: If *PIR Op. Mode Control* is set to Off, the PIR measurement does not have any impact on the control logic.

MULTI-TRIGGER MODE

The PIR mode can be changed to multi-trigger mode. In this mode during the *Trigger Period* the number of movement detections must reach the *PIR Trigger Count* amount for the controller to activate the Occupied Mode. If within the *Trigger Period* the trigger count is not reached, it is reseted to 0. After each movement detection, there is delay of 10 seconds until further movement is registered to the trigger count. This feature can be used, for example, prevent the system to switch on if a person enters temporarily to the room space.

Parameter	Description	Value Range / Enumerations
PIR Tigger Mode	Selects the MMode of the PIR Sensor	0 - Standard (default) 1 - Multi-Trigger
PIR Trigger Count	Trigger Count in Multi-Trigger Mode	1..10 (default 600 secs)
Trigger Period	Trigger Period for monitoring Trigger Count	30..1,800 seconds (default 300 secs)
PIR Off Delay	Delay Off Timer for the PIR Movement/Occupancy sensor	10..28,800 seconds (default 600 secs)
Inactive PIR Control Mode	Activated Control Mode when the PIR (OE-option) does not detect movement.	0 = Unoccupied Mode (Default) 1 = Off Mode
PIR Op. Mode Control	PIR influence on the operation mode. If set to Off, the PIR only shows the status on the network.	0 = On (Default) 1 = Off

## Universal Input Configuration

Universal Input can be configured to operate as NCT10 (resistive), Analogue (0..10V), Condensation Sensor (Resistive) or Digital On/Off. Configure and wire inputs as required by the application operation using the below diagram as guidance.

NTC10: Use this option to measure temperature using NTC10 temperature sensors. For control loops to use NTC10, select NTC10 in the control loop source parameters.

Digital Modes: Select as appropriate to override the controller operation modes.

Condensation Sensor Option (Option 4): Uses resistive condensation sensor.

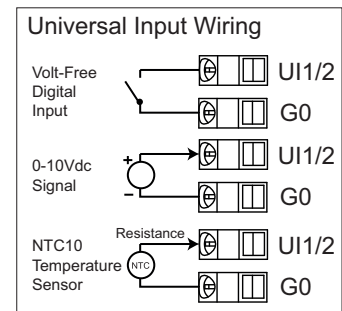

Parameter	Description	Value Range / Enumerations
UI1 Mode	Sets the Universal Input 1 Mode.	0 = Not Used 1 = 0..10V (0..100%) 2 = NTC10 (Default) 3 = Digital - Network 4 = Digital - Disable Cooling / Resistive Condensation Sensor 5 = Digital - Occupied 6 = Digital - Unoccupied 7 = Digital - Off 8 = Digital - Unoccupied / Occupied 9 = Digital - Off / Occupied
UI2 Mode	Sets the Universal Input 2 Mode.  Note: Options 5,6 and 7 override to selected controller mode on OFF to ON transition. Note: Option 8 overrides to Occupied Mode on ON transition and Unoccupied Mode on OFF transition. Note: Option 9 overrides to Occupied Mode on ON transition and Off Mode on OFF transition.	
UI1 Scale Min.	Sets the scaling for Min. Measurement when UI1 @ 0V (0%)	0.0..3000.0 (Default 0)
UI1 Scale Max.	Sets scaling for the Max. Measurement when UI1 @ 10V (100%)	0.0..3000.0 (Default 100.0)
UI2 Scale Min.	Sets the scaling for Min. Measurement when UI2 @ 0V (0%)	0.0..3000.0 (Default 0)
UI2 Scale Max.	Sets scaling for the Max. Measurement when UI2 @ 10V (100%)	0.0..3000.0 (Default 100.0)

UI1/UI2 Input Minimum and Maximum scaling parameters are used to scale 0..10V signal to the measurement. E.g. typical humidity transmitters scaled 0..100%rH measurement to 0..10V on their output. In this case set the *Scale Min.* parameter to 0 and *Scale Max.* parameter to 100.

In case of CO2 transmitter, these scale the 400..2,000ppm reading to 0..10V. In this case set the *Scale Min.* parameter to 400 and *Scale Max.* parameter to 2,000.

NOTE: The controllers have advanced UI1/UI2 voltage clamping settings that can be used to scale e.g. input voltage for e.g. 0..10V = 0..5000ppm CO2 sensors.

## Analogue Output and Valve Control Options

### 0 - 10V OUTPUT CONFIGURATION AND SCALING

The Y1/Y2/Y3 0..10V outputs can be configured to control based on the options in the below table. In addition each output can be scaled between minimum and maximum limits. Reversing the limits is also possible which will reverse the output voltage (e.g. for situations where the 0..10V valve signal closes the valve instead of opening it).

TIP: By setting minimum output position it is possible e.g. set minimum fresh air level to air dampers.

NOTE: At Night Off mode the outputs switch to 0V (or 10V if reverse mode has been activated).

NOTE: Setting the *Output Mode = Network Value*, it is possible to override the output level using *Y1/Y2/Y3 Override Value* parameter. With Modbus models it is also possible to use Commissioning Overrides for the outputs.

NOTE: xCR03 models have only Y1.

Parameter	Description	Value Range / Enumerations
Y1 Output Mode	Y1 Output Configuration Default: Heating Stage 1	0 = Network Value 1 = Heating Stage 1
Y2 Output Mode	Y2 Output Configuration (Only xCR02 and xCR04) Default: Cooling Stage 1	2 = Heating Stage 2 3 = Cooling Stage 1 4 = Cooling Stage 2
Y3 Output Mode	Y3 Output Configuration (Only xCR02 and xCR04) Default: Fan Speed Control	5 = CO2 Demand 6 = Maximum VAV 7 = Fan Demand 8 = 6-Way Valve 9 = Reverse 6-Way Valve
Y1 Minimum	Y1 Output Minimum Level	0.0..100.0% (Default 0%)
Y1 Maximum	Y1 Output Maximum Level	0.0..100.0% (Default 100%)
Y2 Minimum	Y2 Output Minimum Level (Only xCR02 and xCR04)	0.0..100.0% (Default 0%)
Y2 Maximum	Y2 Output Maximum Level (Only xCR02 and xCR04)	0.0..100.0% (Default 100%)
Y3 Minimum	Y3 Output Minimum Level (Only xCR02 and xCR04)	0.0..100.0% (Default 0%)
Y3 Maximum	Y3 Output Maximum Level (Only xCR02 and xCR04)	0.0..100.0% (Default 100%)

### 6-WAY VALVE CONTROL

The 6-way valve option allows the controller to control 6-way valves that can be used for both heating and cooling control, simplifying heating/cooling coil structure. The principle of 6-way valve control is shown in the diagram. To activate the 6-way valve control the 0..10V output (Y1..Y3) is set to '6-way valve'. It is possible to modify the 6-way valve control parameters to suit the different 6-way valve manufacturers. The default settings are provided for Belimo 6-way valve.

Using the 'Reverse 6-Way Valve' option the Sequence 1 and Sequence 2 are swapped. This allows the controller to be configured to suit regardless of the 6-way valve piping.

The table below illustrates the switching parameters for the 6-way control.

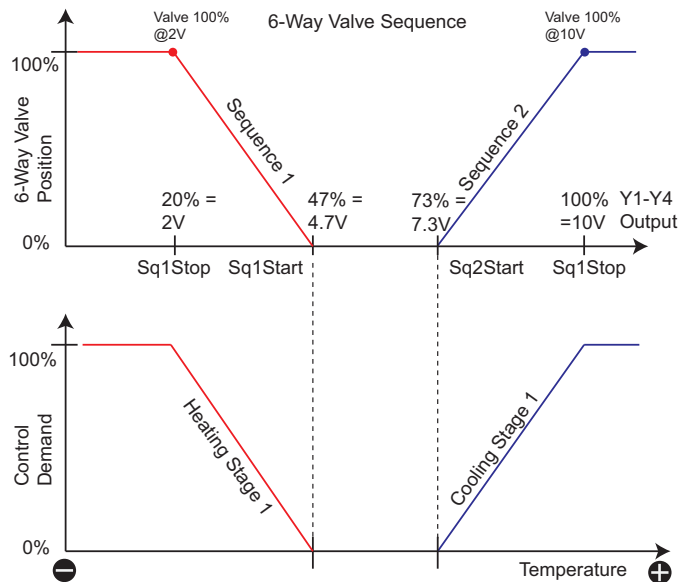

Parameter	Description	Value Range / Enumerations
Sequence 1 Start Value (Sq1Start)	6-Way Valve Sequence 1 Start Voltage. With setting '6-Way Valve' Main Loop Heating Stage 1 at 0% Demand.	0..100% (Default 47% = 4.7V)
Sequence 1 Stop Value (Sq1Stop)	6-Way Valve Sequence 1 Stop Voltage. With setting '6-Way Valve' Main Loop Heating Stage 1 at 100% Demand.	0..100% (Default 20% = 2V)
Sequence 2 Start Value (Sq2Start)	6-Way Valve Sequence 2 Start Voltage. With setting '6-Way Valve' Main Loop Cooling Stage 1 at 0% Demand.	0..100% (Default 73% = 7.3V)

Sequence 2 Stop Value (Sq2Stop)	6-Way Valve Sequence 2 Stop Voltage. With setting '6-Way Valve' Main Loop Cooling Stage 1 at 100% Demand.	0..100% (Default 100% = 10V)
---------------------------------	---	------------------------------

## Digital Output Control Options

### DIGITAL TRIAC OUTPUT CONTROL OPTIONS

The xCR02/03/04 series controllers have 2 x 24Vac Triac. The triacs can operate in On/Off and PWM (Pulse-Width Modulation) configurations.

In the PWM mode the output is modulated using pulse-width-modulation sequence. With On/Off Mode the outputs are switched ON at 'DO On Value' and OFF at 'DO Off Value'.

TIP: Use TRs Direction parameter to reverse the PWM / ON-Off output.

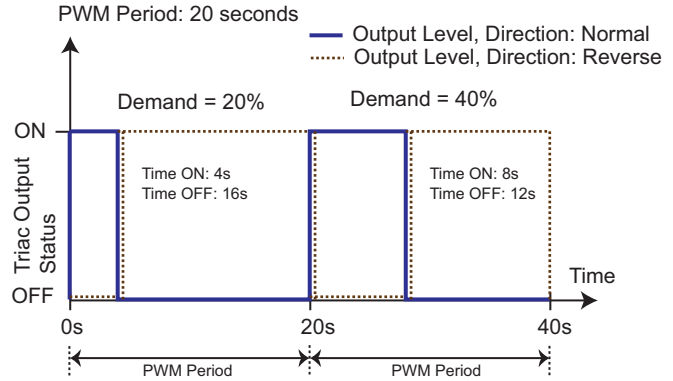

NOTE: Setting the TR1/TR2 Mode = Network, it is possible to override the output level using TR1/TR2 Override Value parameter. With Modbus models it is also possible to use Commissioning Overrides for overriding the triac output levels.

Parameter	Description	Value Range / Enumerations
TR1 Output Mode	Triac Output 1 Configuration Default: Heating Stage 1	0 = Network Value 1 = Heating Stage 1 2 = Heating Stage 2 3 = Cooling Stage 1 4 = Cooling Stage 2 5 = CO2 Demand 6 = Maximum VAV 7 = FanSpeed1 8 = FanSpeed2 9 = FanSpeed3 10 = Fan Demand 11 = None
TR2 Output Mode	Triac Output 2 Configuration Default: Cooling Stage 1  Triac Output: Options 1-6 and 10 is controlled using either PWM or ON/Off Modes  Triac Output: Options 7-9 is controlled as ON/OFF based on the fan control source demand (Set Fan Mode = Stepped). FanSpeed1 is ON when source > Fan Speed 1 Level (in fan control settings), FanSpeed2 when source > Fan Speed Level 2 and FanSpeed3 when source > Fan Speed Level 3. Hysteresis of 5% applies.	
PWM Period	PWM Control Logic Period. The controller calculates the new sequence at these intervals. Setting the PWM period to 0, configures the output to operate as On/Off	0..180s (Default 20s)
TR/RL ON Value	The value at the Triac (or Relay) Output Switches ON. Only applied when PWM Period is set to 0.	0..100% (Default 50%)
TR/RL OFF Value	The value at the Triac (or Relay) Output Switches OFF	0..100% (Default 0%)
TR1 Direction	Triac Output 1 Direction	0 = Normal (Default) 1 = Reverse
TR2 Direction	Triac Output 2 Direction	
TR1 Type	Triac 1 Type	0 = On-Off 1 = PWM (Default)
TR2 Type	Triac 2 Type	

## Relay Output Control Options (xCR03 Models)

### RELAY OUTPUT CONTROL OPTIONS (XCR03 MODELS ONLY)

xCR03 models have 3 x 230Vac relays that can be used for control purposes. The relays are as default configured for 3-speed fan control, but can also be independently controlled for other purposes. The relays are configured under *Relay Output Settings*.

The relays are switched on when the control source value exceed TR/RL ON Value, and the relays are switched OFF when the control source value is less than TR/RL OFF Value.

NOTE: When controlling relays using (default) *Fan Speed 1/2/3* settings, it is possible to apply delay between relay switching using *751: Fan Relay Delay* parameter (under *Fan Control*).

Parameter	Description	Value Range / Enumerations
RL1 Output Mode	Relay 1 Output Control Source Configuration Default: Fan Speed 1	0 = Network Value 1 = Heating Stage 1 2 = Heating Stage 2 3 = Cooling Stage 1 4 = Cooling Stage 2 5 = CO2 Demand 6 = Maximum VAV 7 = Fan Demand 8 = 6-Way Valve 9 = Reverse 6-Way Valve 10 = Fan Speed 1 11 = Fan Speed 2 12 = Fan Speed 3
RL2 Output Mode	Relay 2 Output Control Source Configuration Default: Fan Speed 2	
RL3 Output Mode	Relay 3 Output Control Source Configuration Default: Fan Speed 3	
TR/RL ON Value	The value at the Relay (or Triac) Output Switches ON.	0..100% (Default 50%)
TR/RL OFF Value	The value at the Relay (or Triac) Output Switches OFF	0..100% (Default 0%)

The Relay outputs can be overridden in Modbus using the Commissioning Overrides (Auto, 0%-OFF, 100%-ON), and in BACnet using the AV objects.

## Output Exercise Function

The TCR/QCR02/03/04 series controllers have Valve/Output Exercise function that allows each of the outputs (Analogue, Digital) to be exercised automatically in case of inactivity (meaning output remains at 0% or 100% for the specified time). The inactivity setting can be set between 0..255 days. Each of the outputs can be individually enabled by setting the Exercise Duration parameter.

During the exercise the output remains at 0% or 100% depending on the inactivity level. After the exercise time, the next output is held off for the exercise time duration, allowing the exercise output to return under normal control.

Parameter	Description	Value Range / Enumerations
Exercise Active	Parameter reporting Exercise Mode status.	0 = None, 1=Y1, 2=Y2, 3=Y3, 5=TR1, 6=TR2
Exercise Interval	Sets the period of inactivity to activate the corresponding output.	0..255 days (Default 0 days)
Y1 Duration	Analogue Output 1 Exercise Time. After configured period of inactivity, the output is driven to 50% for the Y1 Duration Time	0..255 Minutes (Default: 0) 0 = Disabled
Y2 Duration	Analogue Output 2 Exercise Time. After configured period of inactivity, the output is driven to 50% for the Y2 Duration Time (Only on xCR02 and xCR04)	0..255 Minutes (Default: 0) 0 = Disabled
Y3 Duration	Analogue Output 3 Exercise Time. After configured period of inactivity, the output is driven to 50% for the Y3 Duration Time (Only on xCR02 and xCR04)	0..255 Minutes (Default: 0) 0 = Disabled
TR1 Duration	Triac Output 1 Exercise Time. After configured period of inactivity, the output is driven to opposite state for the TR1 Duration Time	0..255 Minutes (Default: 0) 0 = Disabled
TR2 Duration	Triac Output 2 Exercise Time. After configured period of inactivity, the output is driven to opposite state for the TR2 Duration Time	0..255 Minutes (Default: 0) 0 = Disabled

## User Interface

The controllers have colour LCD display and three push buttons for the user operation. The screen indicates the controller status and measurements and provides the user interface.

### LCD DISPLAY



The display has area for controller status indication and main area for the temperature / CO2 and setpoint display. The display main are can be configured to show:-

- 0 = Temperature Measurement Only (large text)
- 1 = Temperature Setpoint Only (large text)
- 2 = CO2 Measurement Only (large text)
- 3 = Temperature Measurement and Large Setpoint (Default)
- 4 = Large Temperature and CO2 Measurement
- 5 = Temperature and CO2 Measurement, Large Temperature Setpoint
- 6 = Large Temperature Display and Setpoint
- 7 = Large Temperature Display, Setpoint and CO2

### SETPOINT ADJUSTMENT BUTTONS

Pressing the setpoint button upwards or downwards, the current setpoint is displayed and can be adjusted.

### FAN SPEED ADJUSTMENT BUTTON

By pressing the Fan button the fan speed can be adjusted, rotates from the current setting forward with the following sequence (Auto-0-1, Auto-0-1-2, Auto-0-1-2-3) depending on the configuration.

The current fan speed and the selected fan speed is displayed on the status bar.

### OPERATING MODE BUTTON

With OM models the third button becomes as Operating Mode selection button (rotates Occupied/Unoccupied/Off modes). Set 605: *Mode Button = 1: Occupied* to enable this mode.

### BOOST BUTTON

With BST models the third button becomes as Boost button. Set 605: *Mode Button = 2: Boost* to enable this mode. In boost mode when the button is pressed the selected control demand is set to 100% for the specified time (or toggle boost on/off). It is also possible to boost the controller to the Occupied mode for the specified time. This especially useful in meeting rooms etc. to activate the Occupied mode.

### BUTTONS

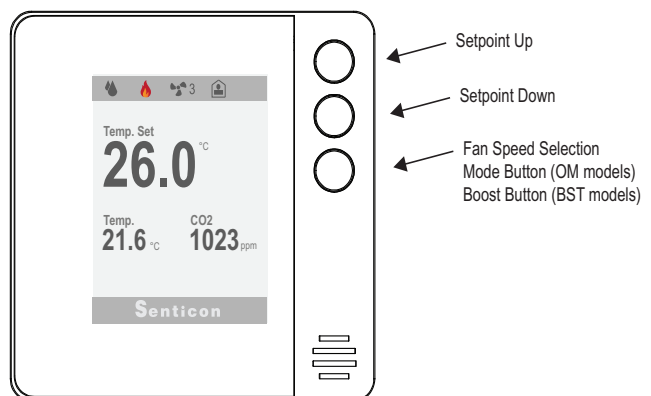

## Device Setup and Modbus/BACnet Communications

The devices are available with Modbus RTU or BACnet MS/TP communication for system integration. Please also note that the devices can be configured via Modbus or via BACnet MS/TP. Alternatively the devices can be configured locally using via PC Based Smart Config Tool or via iOS Smart Phone Application. Using any of these methods the device settings can be altered to suit the site requirements and the current device status can be interrogated.

Modbus and BACnet communication is carried out over RS485 serial network.

The Windows Smart Config Tool and iOS Smart Phone Application are connected to the device using Bluetooth dongle set (BLE-TOOLSET) that are plugged into the PC USB port and to the device (connection to device illustrated below).

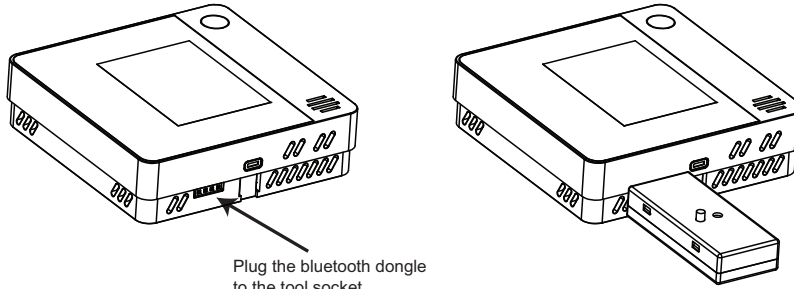

### MODBUS / BACNET NETWORK SETUP

**NOTE: Modbus RS485 or BACnet MS/TP versions are hardware specific models. It is not possible to change the communication protocol on the device. Please make sure to order the required model.**

The devices can operate either as Modbus RTU RS485 slave device, or BACnet MS/TP Server. The device (slave/MAC) address and baud rate (limited) are set up through Windows Smart Configuration Tool / iOS Smart Phone App, through display or using bit switches for TCR04/QCR04 series.

### xCR04 SERIES BIT SWITCH

With xCR04 series the address is also possible to set up using the bit switch. Follow the below guidelines.

Bit switches 1-7 act as a binary decoder to set the (slave/MAC) address. Set these bit switches to OFF position if the address is configured by the software.

Bit switches 8 and 9 are used to set the baud rate. Set these bit switches to OFF position if the baud rate is configured by the software.

Bit switch EOL is used to activate 120 Ohm RS485 network End of Line termination (only used on the end of line devices).

**NOTE:** Once bit switches are changed the device will automatically carry out soft reset to activate the new settings.

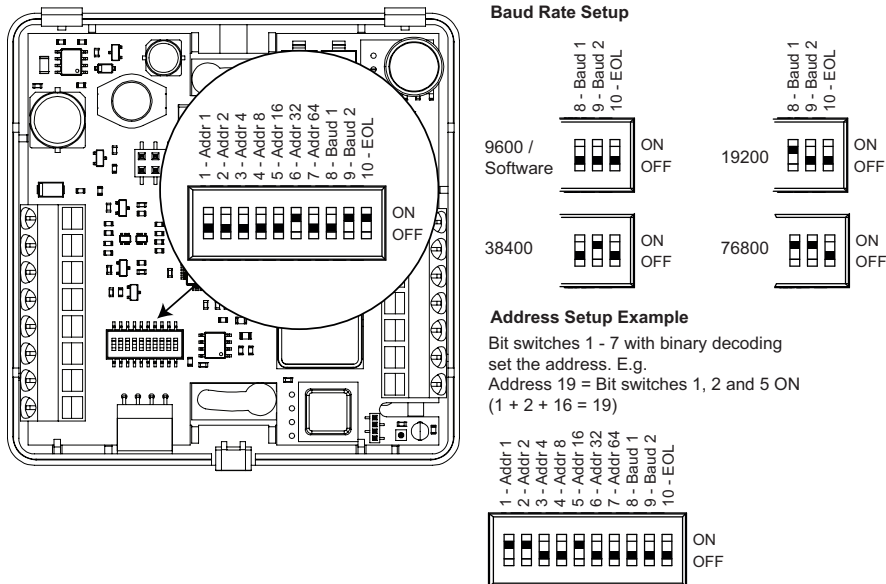

**ADDRESS CONFIGURATION VIA DISPLAY**

It is possible to change the device Modbus/MAC address via the display. Press UP and DOWN arrows at the same time continuously for approx. 5 seconds to enter the address configuration screen. Follow the instructions on the below diagram to change the settings.

NOTE: With xCR04 series the Config Screen mode has been set Read Only as default. The mode is configurable through parameter 816 under *Display Settings*.

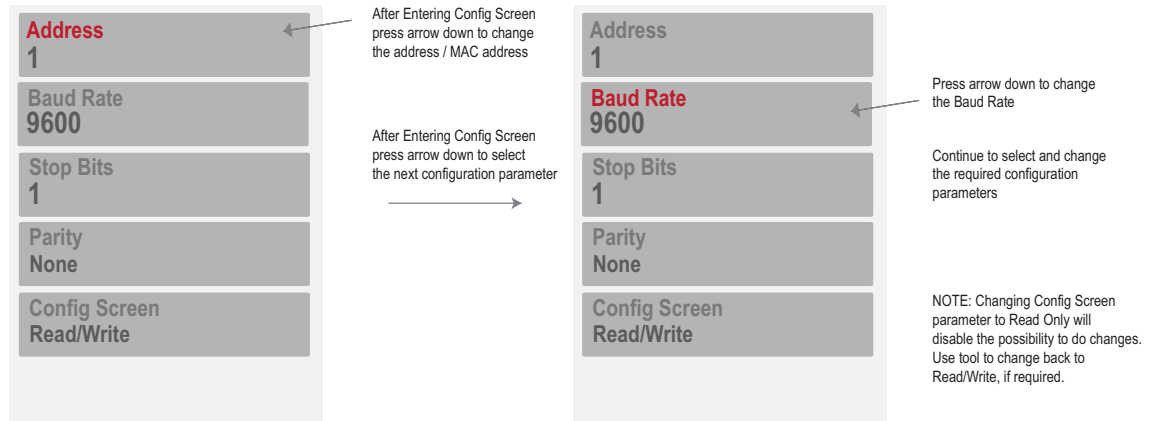

**DEVICES CONFIGURATION PARAMETERS**

NOTE: Please note that Modbus register addresses start with 0 (0-based). If your Modbus master addresses start from one (1), then you will need to add one to the register values. If your Modbus master uses zero based addressing then the registers can be used as is.

NOTE: BACnet configuration parameter addresses are split to multiple instances of the Device Configuration object.

NOTE: Reg Field shows the Modbus register offset. The Reg field number is also the same with BACnet Device Configuration Objects.

NOTE: If the configuration parameters are changed over the Modbus or BACnet using third party tools such as Modbus clients or Yabe for BACnet, please ensure that System Parameter 811 - Persist is applied after the configuration to store the new settings permanently.

LIVE DATA						
Parameter	Description	MODBUS INPUT REGISTERS - FUNCTION CODE 04 MODBUS HOLDING REGISTER - FUNCTION CODES 03, 16			Value Range / Enumerations	R/W
		Reg	Type	Data Range (multiplier)		
<b>INPUTS</b>						
Temperature Sensor	Displays current temperature measurement reading (built-in sensor) Note: Value depends on the temperature unit °C/°F selection	400	int16	-400..2480 (x10)	-40.0..120.0°C / -40.0..248.0°F	R
CO2 Sensor	Displays current measurement CO2 reading (QCR controllers)	402	uint16	0..10,000 (x1)	0..10,000ppm	R
UI1	Universal Input 1 Measurement Note: Value depends on the temperature / mode selection	410	int16	-400..2480 (x10)	NTC Mode: -40..120° AI Mode: 0..100% = 0..10V	R
UI2	Universal Input 2 Measurement Note: Value depends on the temperature / mode selection	411	int16	-400..2480 (x10)	NTC Mode: -40..120° AI Mode: 0..100% = 0..10V	R
<b>DISCRETE INPUTS - FUNCTION CODE 02</b>						
DI1	Digital Input 1 Status	200		0..1	0..1	R
DI2	Digital Input 2 Status	201		0..1	0..1	R
PIR Status	PIR (OE Option) Status	202		0..1	0..1	R
Boost Status	Boost Status	204		0..1	0..1	R
<b>OUTPUTS</b>						

		MODBUS INPUT REGISTERS - FUNCTION CODE 04 MODBUS HOLDING REGISTER - FUNCTION CODES 03, 16				
Y1	Analogue Output 1 Value	412	uint16	0..1000 (x10)	0..100% = 0..10V	R
Y2	Analogue Output 2 Value (xCR02 and xCR04 Only)	413	uint16	0..1000 (x10)	0..100% = 0..10V	R
Y3	Analogue Output 3 Value (xCR02 and xCR04 Only)	414	uint16	0..1000 (x10)	0..100% = 0..10V	R
RL1	Relay 1 Control Level (xCR03 Only)	413	uint16	0..1000 (x10)	0..100%	R
RL2	Relay 2 Control Level (xCR03 Only)	414	uint16	0..1000 (x10)	0..100%	R
RL3	Relay 3 Control Level (xCR03 Only)	415	uint16	0..1000 (x10)	0..100%	R
Exercise Active	Reports Output that is in the Exercise Mode	418	uint16	0..6 (x1)	0 = None, 1=Y1, 2=Y2, 3=Y3, 5=TR1, 6=TR2	R
		DISCRETE INPUTS - FUNCTION CODE 02				
Triac 1 Status	Triac 1 Output Status	206		0..1	0..1	R
Triac 2 Status	Triac 2 Output Status	207		0..1	0..1	R
DEMAND SIGNALS						
		MODBUS INPUT REGISTERS - FUNCTION CODE 04 MODBUS HOLDING REGISTER - FUNCTION CODES 03, 16				
Calculated Multi-Stage Setpoint	Calculated Setpoint (Nominal Network Setpoint + User Adjustment) for Multi-Stage Control Loop <b>Note:</b> Read/write Modbus parameter. Writing to Reg420 sets 701 Nominal Setpoint to this value, and the user adjustment is reset to 0.	420	int16	-32000..32000 (x10)	-3200.0..3200.0	R/W
Heating Demand	Heating Stage Demand (Multi-Loop Heating Stage 1/2/3)	422	int16	0..1000 (x10)	0..100%	R
Cooling Demand	Cooling Stage Demand (Multi-Loop Cooling Stage 1/2/3)	423	int16	0..1000 (x10)	0..100%	R
Current Control Mode	Current Control Mode Status	424	int16	0..2 (x1)	0 = Occupied 1 = Unoccupied 2 = Night	R
Cooling Status	Main Loop Cooling Stage Override Status	425	int16	0..1 (x1)	0 = Normal Operation 1 = Digital Input Disable (Condensation)	R
Fan Demand	Fan Loop Demand	427	int16	0..1000 (x10)	0..100%	R
Fan Mode	Current Fan Mode	437	int16	0..4 (x1)	0 = Off 1 = Manual Speed 1 2 = Manual Speed 2 3 = Manual Speed 3 4 = Auto	R
CO2 Demand	CO2 Loop Demand	428	int16	0..1000 (x10)	0..100%	R
Triac 1 PWM Demand	Triac Output 1 PWM Demand Note: For On/Off or 3-Point Modes shows 0% when Off and 100% when On.	431	int16	0..1000 (x10)	0..100%	R
Triac 2 PWM Demand	Triac Output 2 PWM Demand	432	int16	0..1000 (x10)	0..100%	R

INPUT/OUTPUT SETTINGS						
Parameter	Description	Modbus Register / BACnet Property	MODBUS HOLDING REGISTER - FUNCTION CODES 03, 06, 16		Value Range / Enumerations	R/W
			Type	Data Range (multiplier)		
UNIVERSAL INPUTS						
UI1 Voltage Min.	Sets Min. Clamp Voltage for UI1.	516	uint16	0..100 (x10)	0..10.0 (Default 0)	R/W
UI1 Voltage Max.	Sets Max. Clamp Voltage for UI1. Use only if the connected device upper range is more than 3000.	517	uint16	0..100 (x10)	0..10.0 (Default 10.0)	R/W
UI2 Voltage Min.	Sets Min. Clamp Voltage for UI2. Advanced Setting.	518	uint16	0..100 (x10)	0..10.0 (Default 0)	R/W

UI2 Voltage Max.	Sets Max. Clamp Voltage for UI2. Use only if the connected device upper range is more than 3000.	519	unit16	0..100 (x10)	0..10.0 (Default 10.0)	R/W
UI1 Mode	Sets the Universal Input 1 Mode	520	unit16	0..9 (x1)	0 = Not Used 1 = 0..10V (0..100%) 2 = NTC10 (Default) 3 = Digital - Network 4 = Digital - Disable Cooling / Resistive Condensation Sensor 5 = Digital - Occupied 6 = Digital - Unoccupied 7 = Digital - Off 8 = Digital - Unoccupied / Occupied 9 = Digital - Off / Occupied	R/W
UI2 Mode	Sets the Universal Input 2 Mode.  Note: Options 5,6 and 7 override to selected controller mode on OFF to ON transition.  Note: Option 8 overrides to Occupied Mode on ON transition and Unoccupied Mode on OFF transition.  Note: Option 9 overrides to Occupied Mode on ON transition and Off Mode on OFF transition.	521	unit16	0..9 (x1)		R/W
Temperature Units	Sets the temperature measurement and display to operate in Celcius or Fahrenheit. Note: To show Fahrenheit on display set the correct Unit setting on the display.	522	unit16	0..1 (x1)		0 = Celcius (Default) 1 = Fahrenheit
UI1 Scale Min.	Sets the scaling for Min. Measurement when UI1 @ 0V (0%)	523	unit16	0..30000 (x10)	0.0..3000.0 (Default 0)	R/W
UI1 Scale Max.	Sets scaling for the Max. Measurement when UI1 @ 10V (100%)	524	unit16	0..30000 (x10)	0.0..3000.0 (Default 100.0)	R/W
UI2 Scale Min.	Sets the scaling for Min. Measurement when UI2 @ 0V (0%)	525	unit16	0..30000 (x10)	0.0..3000.0 (Default 0)	R/W
UI2 Scale Max.	Sets scaling for the Max. Measurement when UI2 @ 10V (100%)	526	unit16	0..30000 (x10)	0.0..3000.0 (Default 100.0)	R/W
UI1 Digital Polarity	UI1 Digital Input Polarity Setting - allows the polarity of the input operation to be reversed when used in digital modes.	527	unit16	0..1 (x1)	0 = Normal (Default) 1 = Reverse	R/W
UI2 Digital Polarity	UI2 Digital Input Polarity Setting - allows the polarity of the input operation to be reversed when used in digital modes..	528	unit16	0..1 (x1)	0 = Normal (Default) 1 = Reverse	R/W

**ANALOGUE OUTPUTS**

Y1 Mode	Y1 Output Configuration Default: Heating Stage 1	530	unit16	0..9 (x1)	0 = Network Value 1 = Heating Stage 1 2 = Heating Stage 2 3 = Cooling Stage 1 4 = Cooling Stage 2 5 = CO2 Demand 6 = Maximum VAV 7 = Fan Demand 8 = 6-Way Valve 9 = Reverse 6-Way Valve	R/W
Y2 Mode	Y2 Output Configuration (xCR02 and xCR04 only) Default: Cooling Stage 1	531	unit16	0..9 (x1)		R/W
Y3 Mode	Y3 Output Configuration (xCR02 and xCR04 only) Default: Fan Speed Control	532	unit16	0..9 (x1)		R/W
Y1 Override	Analogue Output Y1 Override Value. Note: Only applicable when source is set to Network.	534	unit16	0..1000 (x10)	0.0..100.0% (Default 0)	R/W
Y2 Override	Analogue Output Y2 Override Value (xCR02 and xCR04 only). Note: Only applicable when source is set to Network.	535	unit16	0..1000 (x10)	0.0..100.0% (Default 0)	R/W
Y3 Override	Analogue Output Y3 Override Value (xCR02 and xCR04 only). Note: Only applicable when source is set to Network.	536	unit16	0..1000 (x10)	0.0..100.0% (Default 0)	R/W
Network Value 1	Network Value 1. For Multi-Stage or Change-Over Control.	538	int16	-9990..9990 (x10)	-999.0..999.0 (Default 0)	R/W
Network Value 2	Network Value 2 (for CO2 control)	539	uint16	0..65535 (x1)	0..65535 (Default 0)	R/W
Y1 Minimum	Y1 Output Minimum Level	540	unit16	0..1000 (x10)	0.0..100.0% (Default 0%)	R/W
Y1 Maximum	Y1 Output Maximum Level	541	unit16	0..1000 (x10)	0.0..100.0% (Default 100%)	R/W
Y2 Minimum	Y2 Output Minimum Level (xCR02 and xCR04 only)	542	unit16	0..1000 (x10)	0.0..100.0% (Default 0%)	R/W
Y2 Maximum	Y2 Output Maximum Level (xCR02 and xCR04 only)	543	unit16	0..1000 (x10)	0.0..100.0% (Default 100%)	R/W
Y3 Minimum	Y3 Output Minimum Level (xCR02 and xCR04 only)	544	unit16	0..1000 (x10)	0.0..100.0% (Default 0%)	R/W
Y3 Maximum	Y3 Output Maximum Level (xCR02 and xCR04 only)	545	unit16	0..1000 (x10)	0.0..100.0% (Default 100%)	R/W
Sequence 1 Start Value (Sq1Start)	6-Way Valve Sequence 1 Start Voltage. With setting '6-Way Valve' Main Loop Heating Stage 1 at 0% Demand.	548	unit16	0..100 (x10)	0..100% (Default 47%)	R/W
Sequence 1 Stop Value (Sq1Stop)	6-Way Valve Sequence 1 Stop Voltage. With setting '6-Way Valve' Main Loop Heating Stage 1 at 100% Demand.	549	unit16	0..100 (x10)	0..100% (Default 20%)	R/W
Sequence 2 Start Value (Sq2Start)	6-Way Valve Sequence 2 Start Voltage. With setting '6-Way Valve' Main Loop Cooling Stage 1 at 0% Demand.	550	unit16	0..100 (x10)	0..100% (Default 73%)	R/W
Sequence 2 Stop Value (Sq2Stop)	6-Way Valve Sequence 2 Stop Voltage. With setting '6-Way Valve' Main Loop Cooling Stage 1 at 100% Demand.	551	unit16	0..100 (x10)	0..100% (Default 100%)	R/W

DIGITAL INPUTS						
DI1 Off Delay	Delay Off Timer for the Universal Input 1 in Digital Input Mode	560	uint16	0..28,800 (x1)	0..28,800 seconds (default 0 secs)	R/W
DI2 Off Delay	Delay Off Timer for the Universal Input 2 in Digital Input Mode	561	uint16	0..28,800 (x1)	0..28,800 seconds (default 0 secs)	R/W
PIR Tigger Mode	Selects the MOde of the PIR Sensor	685	uint16	0..1 (x1)	0 - Standard (default) 1 - Multi-Trigger	R/W
PIR Trigger Count	Trigger Count in Multi-Trigger Mode	686	uint16	1..10 (x1)	1..10 (default 3 )	R/W
Trigger Period	Trigger Period for monitoring Trigger Count	687	uint16	30..1,800 (x1)	30.1,800 seconds (default 300 secs)	R/W
PIR Off Delay	Delay Off Timer for the PIR Movement/Occupancy sensor	562	uint16	10..28,800 (x1)	10..28,800 seconds (default 600 secs)	R/W

DIGITAL (TRIAC) OUTPUTS						
TR1 Output Mode	Triac Output 1 Configuration Default: Heating Stage 1	570	uint16	0..11 (x1)	0 = Network 1 = Heating Stage 1	R/W
TR2 Output Mode	Triac Output 2 Configuration Default: Cooling Stage 1  Triac Output: Options 1-6 and 10 is controlled using either PWM or ON/Off Modes.  Triac Output: Options 7-9 is controlled as ON/OFF based on the fan control source demand (Set Fan Mode = Stepped). <i>FanSpeed1</i> is ON when source > Fan Speed 1 Level (in fan control settings), <i>FanSpeed2</i> when source > Fan Speed Level 2 and <i>FanSpeed3</i> when source > Fan Speed Level 3. Hysteresis of 5% applies.	571	uint16	0..11 (x1)	2 = Heating Stage 2 3 = Cooling Stage 1 4 = Cooling Stage 2 5 = CO2 Demand 6 = Maximum VAV 7 = Fan Speed 1 9 = Fan Speed 2 9 = Fan Speed 3 10 = Fan Demand 11 = None	R/W
PWM Period	PWM Control Logic Period. The controller calculates the new sequence at these intervals. Setting the PWM period to 0, configures the output to operate as On/Off using 'DO ON' and 'DO OFF' Values.	574	uint16	0..180 (x1)	0..180s (Default 20s)	R/W
TR1 Direction	Triac Output 1 Direction	577	uint16	0..1 (x1)	0 = Normal (Default) 1 = Reverse	R/W
TR2 Direction	Triac Output 2 Direction	578	uint16	0..1 (x1)	0 = Normal (Default) 1 = Reverse	R/W
Triac 1 Level Override	Triac 1 Output (PWM) Network Override Note: Set output to Network	583	uint16	0..100 (x1)	0% = OFF (default) 100% = ON	R/W
Triac 2 Level Override	Triac 2 Output (PWM) Network Override Note: Set output to Network	584	uint16	0..100 (x1)	1%.99% = ON/OFF based on Pulse Width Modulation Settings	R/W
TR1 Type	Triac 1 Type (from Fw1.09)	555	uint16	0..1 (x1)	0 = On-Off 1 = PWM (Default)	R/W
TR2 Type	Triac 2 Type (from Fw1.09)	556	uint16	0..1 (x1)		R/W
TR/RL ON Value	The value at the Triac (or Relay) Output Switches ON Note: Same parameter is used on xCR03 for Relay Switching thresholds.	575	unit16	0..100 (x1)	0..100% (Default 50%)	
TR/RL OFF Value	The value at the Triac (or Relay) Output Switches OFF Note: Same parameter is used on xCR03 for Relay Switching thresholds.	576	unit16	0..100 (x1)	0..100% (Default 0%)	R/W

RELAY OUTPUT SETTINGS (xCR03 ONLY)						
RL1 Output Mode	Relay 1 Output Source Configuration (xCR03 Only) Default: Fan Speed 1	531	unit16	0..12 (x1)	0 = Network Value 1 = Heating Stage 1	R/W
RL2 Output Mode	Relay 2 Output Source Configuration (xCR03 Only) Default: Fan Speed 2	532	unit16	0..12 (x1)	2 = Heating Stage 2 3 = Cooling Stage 1	R/W
RL3 Output Mode	Relay 3 Output Source Configuration (xCR03 Only) Default: Fan Speed 3	533	unit16	0..12 (x1)	4 = Cooling Stage 2 5 = CO2 Demand 6 = Maximum VAV 7 = Fan Demand 8 = 6-Way Valve 9 = Reverse 6-Way Valve 10 = Fan Speed 1 11 = Fan Speed 2 12 = Fan Speed 3	R/W

TR/RL ON Value	The value at the Relay (or triac) Output Switches ON Note: Used also for triac outputs.	575	uint16	0..100 (x1)	0..100% (Default 50%)	
TR/RL OFF Value	The value at the Relay (or triac) Output Switches OFF Note: Used also for triac outputs.	576	uint16	0..100 (x1)	0..100% (Default 0%)	R/W
RL1 Override	RL1 Control Source Override Value (xCR03 only). Note: Only applicable when source is set to Network.	535	uint16	0..1000 (x10)	0.0..100.0% (Default 0)	R/W
RL2 Override	RL2 Control Source Override Value (xCR03 only). Note: Only applicable when source is set to Network.	536	uint16	0..1000 (x10)	0.0..100.0% (Default 0)	R/W
RL3 Override	RL3 Control Source Override Value (xCR03 only). Note: Only applicable when source is set to Network.	537	uint16	0..1000 (x10)	0.0..100.0% (Default 0)	R/W

OUTPUT AUTO EXERCISE						
Exercise Interval	Sets the period of inactivity to activate the corresponding output.	500	uint16	0..255 (x1)	0..255 days (Default 0 days)	R/W
Y1 Duration	Analogue Output 1 Exercise Time. After configured period of inactivity, the output is driven to 50% for the Y1 Duration Time	501	uint16	0..255 (x1)	0..255 Minutes (Default: 0) 0 = Disabled	R/W
Y2 Duration	Analogue Output 2 Exercise Time. After configured period of inactivity, the output is driven to 50% for the Y2 Duration Time (xCR02 and xCR04 only)	502	uint16	0..255 (x1)	0..255 Minutes (Default: 0) 0 = Disabled	R/W
Y3 Duration	Analogue Output 3 Exercise Time. After configured period of inactivity, the output is driven to 50% for the Y3 Duration Time (xCR02 and xCR04 only)	503	uint16	0..255 (x1)	0..255 Minutes (Default: 0) 0 = Disabled	R/W
TR1 Duration	Triac Output 1 Exercise Time. After configured period of inactivity, the output is driven to opposite state for the TR1 Duration Time	505	uint16	0..255 (x1)	0..255 Minutes (Default: 0) 0 = Disabled	R/W
TR2 Duration	Triac Output 2 Exercise Time. After configured period of inactivity, the output is driven to opposite state for the TR2 Duration Time	506	uint16	0..255 (x1)	0..255 Minutes (Default: 0) 0 = Disabled	R/W

COMMISSIONING OVERRIDES (Modbus Versions Only)						
Y1 Commission Override	Y1 Commissioning Override Parameter	690	uint16	0..3 (x1)	0 = Auto (Default) 1 = Manual Override 2 = 0% 3 = 100%	R/W
Y2 Commission Override	Y2 Commissioning Override Parameter (xCR02 and xCR04 only)	691	uint16	0..3 (x1)		R/W
Y3 Commission Override	Y3 Commissioning Override Parameter (xCR02 and xCR04 only)	692	uint16	0..3 (x1)		R/W
Y1 Override	Analogue Output Y1 Override Value (used when 690 = Manual)	534	uint16	0..1000 (x10)	0.0..100.0% (Default 0)	R/W
Y2 Override	Analogue Output Y2 Override Value (used when 691 = Manual) (xCR02 and xCR04 only)	535	uint16	0..1000 (x10)	0.0..100.0% (Default 0)	R/W
Y3 Override	Analogue Output Y3 Override Value (used when 692 = Manual) (xCR02 and xCR04 only)	536	uint16	0..1000 (x10)	0.0..100.0% (Default 0)	R/W
RL1 Commission Override	Relay 1 Commissioning Override Parameter (xCR03 only)	691	uint16	0..3 (x1)	0 = Auto (Default) 1 = not applicable 2 = 0% 3 = 100%	R/W
RL2 Commission Override	Relay 2 Commissioning Override Parameter (xCR03 only)	692	uint16	0..3 (x1)		
RL3 Commission Override	Relay 3 Commissioning Override Parameter (xCR03 only)	693	uint16	0..3 (x1)		
TR1 Commissioning Override	TR1 Commissioning Override Parameter	694	uint16	0..3 (x1)	0 = Auto (Default) 1 = Manual Override 2 = 0% 3 = 100%	R/W
TR2 Commissioning Override	TR2 Commissioning Override Parameter	695	uint16	0..3 (x1)		R/W
Triac 1 Level Override	Triac 1 Output (PWM) Network Override Note: Set output to Network	583	uint16	0..100 (x1)	0% = OFF (default) 100% = ON 1%.99% = ON/OFF based on Pulse Width Modulation Settings	R/W
Triac 2 Level Override	Triac 2 Output (PWM) Network Override Note: Set output to Network	584	uint16	0..100 (x1)		R/W

CALIBRATION SETTINGS						
Parameter	Description	Modbus Register / BACnet Property	MODBUS HOLDING REGISTER - FUNCTION CODES 03, 06, 16		Value Range / Enumerations	R/W
			Type	Data Range (multiplier)		
Temperature Offset	Built-In Temperature Single Point Sensor Calibration Offset	590	int16	-100..100 (x10)	-10.0..+10.0deg (Default 0)	R/W
CO2 Offset	CO2 Single Point Calibration Offset (adjusts CO2 reading the specified amount)	592	int16	-500..500 (x1)	-500..+500ppm (Default 0)	R/W
CO2 Auto-Calibration	Shows if the auto-calibration of the CO2 has been Activated	593	uint16	0..1	0 = Disabled 1 = Enabled (Default)	R/W
CO2 Calibration Value	Single Point Calibration Value for the CO2 Sensor. Note: Writing this value will reset the calibration settings of the sensor to the value set. Only recommended for advanced users.	594	uint16	350..3,000 (x1)	350..3,000ppm (Default 400)	R/W
Force CO2 Calibration	Forces CO2 Calibration to the CO2 Calibration Value. Use when CO2 level known e.g with calibration gas or outside air.	595	uint16	0..1	0 = None 1 = Force Calibration	R/W
CO2 Calibration Persist	Store CO2 Calibration Settings in the Permanent Memory	596	uint16	0..1	0 = None 1 = Save Data	R/W

USER INTERGFACE SETTINGS						
Parameter	Description	Modbus Register / BACnet Property	MODBUS HOLDING REGISTER - FUNCTION CODES 03, 06, 16		Value Range / Enumerations	R/W
			Type	Data Range (multiplier)		
<b>GENERAL</b>						
Display Mode	Selects the display mode.	600	uint16	0..7	0 = Temperature Measurement Only 1 = Temperature Setpoint Only 2 = CO2 Measurement Only 3 = Temperature Measurement and Large Setpoint (Default) 4 = Large Temperature and CO2 Measurement 5 = Temperature and CO2 Measurement, Large Temperature Setpoint 6 = Setpoint and Large Temperature 7 = Setpoint, CO2 and Large Temperature	R/W
Display Brightness	Controls display brightness. Display wakes up to full brightness when one of the buttons is pressed.	601	uint16	0..6	0 = Off 1 = 5% 2 = 10% 3 = 25% 4 = 50% (default) 5 = 75% 6 = 100%	R/W
Occupancy Icon Display	Activates Occupancy Mode Icon display (Occupied / Unoccupied / Off).	602	uint16	0..1	0 = Disabled (default) 1 = Enabled	R/W
Mode Button	Converts the Button 3 to Operate as Occupancy Mode or Boost Button Instead of the Fan (BST and OM models)	605	uint16	0..2	0 = Disabled (Fan, Default) 1 = Occupied / Unocc/ Off 2 = Boost	R/W
Heat/Cool Icon	Activates Heat/Cool icon display.	603	uint16	0..1	0 = Disabled (default) 1 = Enabled	R/W
Enable Fan Display	Enables Fan Speed Display.	604	uint16	0..2	0 = Disabled 1 = Enabled (default)	R/W
Show Logo	Show Logo on the Screen	606	uint16	0..1	0 = Disabled 1 = Enabled (Default)	R/W
Setpoint Mode	Setpoint Display Mode. Temperature = shows the actual setpoint. Adjustment = shows the +/- adjustment of setpoint.	610	uint16	0..1	0 = Temperature (Default) 1 = Adjustment	R/W

Config Screen	Configuration Screen Mode (enter Config Screen by pressing UP & DOWN arrow for 5 seconds)	816	uint16	0..1	0 = Read/Write (Default) 1 = Write Only	R/W
---------------	---	-----	--------	------	--	-----

**CONTROL SETTINGS**

Parameter	Description	Modbus Register / BACnet Property	MODBUS HOLDING REGISTER - FUNCTION CODES 03, 06, 16		Value Range / Enumerations	R/W
			Type	Data Range (multiplier)		

**CONTROL MODES AND OVERRIDES**

PIR Op. Mode Control	Built-in PIR influence on the operation mode. If set to Off, the built-in PIR only shows the status on the network and has no impact on the operating mode.	679	uint16	0..1	0 = On (Default) 1 = Off	R/W
Inactive PIR Control Mode	Controller Mode when the PIR (OE-option) does not detect movement.	680	uint16	0..1	0 = Unoccupied Mode (Default) 1 = Off Mode	R/W
Override Control Mode	Override Current Control Mode (last transition applies e.g. if overridden from network the user can change through the display)	681	uint16	0..2 (x1)	0 = Occupied 1 = Unoccupied 2 = Night	R/W
Reset User Adjustment	Resets the user setpoint adjustments (multi-stage) when operating mode transitions away from the Occupied mode.	684	uint16	0..1	0 = Disabled (Default) 1 = Enabled	R/W

**MULTI-STAGE CONTROL LOOP**

Main Loop Source	Sets the Control Source for the Multi-Stage Control Loop.  Note: If UI mode is NTC, the control value is as measured. If the UI mode is 0-10V, then 0..10V is scaled to measurement according to UI Input Min/Max scaling parameters 523-526.	700	uint16	0..5 (x1)	0 = Network Value (Reg 538) 1 = Temperature (Built-In, Default) 2 = UI1 - NTC10 3 = UI2 - NTC10 4 = UI1 - 0..10Vdc 5 = UI2 - 0..10Vdc	R/W
Main Loop Nominal Setpoint (SPnom)	Main Control Loop Nominal Setpoint Note: The control loop setpoint can be shifted by the high/low limit (cascade) control function indicated by limit icon.	701	uint16	0..2120 (x10)	0.0..212.0, Default 21.0	R/W
Main Setpoint Resolution	Main Setpoint Adjustment Resolution	702	uint16	1..100 (x10)	0.1..10.0 (default 0.1)	R/W
Min Adjustment	User Setpoint Adjustment Min Limit	703	int16	-300..0 (x10)	-30.0..0.0 (Default -3.0)	R/W
Max Adjustment	User Setpoint Adjustment Max Limit	704	uint16	0..300 (x10)	0.0..30.0 (Default 3.0)	R/W
Main Loop PB	Main Control Loop Proportional Band (for each Stage)	705	uint16	1..500 (x1)	1..500 (Default 5)	R/W
Main IA	Main Control Loop Integral Action Time (Set to 0 to disable)	706	uint16	0..3600 (x1)	0..3600s (Default 600s) 0 = Disabled	R/W
No of Heating Stages	Sets the number of heating stages.	707	uint16	0..2 (x1)	0 = None 1 = 1-Stage (default) 2 = 2-Stages	R/W
No of Cooling Stages	Sets the number of cooling stages.	708	uint16	0..2 (x1)	3 = 3 Stages	R/W
Occ Heating Deadzone	Occupied Mode Heating Deadzone	709	uint16	0..300 (x10)	0.0..30.0 (Default 0.5)	R/W
Occ Cooling Deadzone	Occupied Mode Cooling Deadzone	710	uint16	0..300 (x10)	0.0..30.0 (Default 0.5)	R/W
Unocc Heating Deadzone	Unoccupied Mode Heating Deadzone	711	uint16	0..300 (x10)	0.0..30.0 (Default 3.0)	R/W
Unocc Cooling Deadzone	Unoccupied Mode Cooling Deadzone	712	uint16	0..300 (x10)	0.0..30.0 (Default 3.0)	R/W
Frost Setpoint	Off Mode Frost Setpoint	713	uint16	0..600 (x10)	0.0..60.0 (Default 10.0)	R/W

**CHANGE-OVER FUNCTION**

Change-Over Source	Sets the Source for the Change-Over Function.  Note: As default the Network Command is Off i.e. no change-over function is active.	722	uint16	0..4 (x1)	0 = Network Command (Reg 726, Default) 1 = UI1 - NTC10 2 = UI2 - NTC10 3 = Digital Input 1 (UI1) 4 = Digital Input 2 (UI2)	R/W
--------------------	--	-----	--------	-----------	--	-----

Change-Over Target	Target of the Change-Over Control.	<b>723</b>	uint16	0..1 (x1)	0 = None (Default) 1 = Multi-Stage Control Loop	R/W
Change-Over Low Temperature	Temperature below which the change-over is active (cooling stage active). Note: Relevant only for NTC Input 1/2 options.	<b>724</b>	uint16	0..1000 (x10)	0..100.0° Default 18°	R/W
Change-Over High Temperature	Temperature above which the change-over is off (heating stage active, no override on control). Note: Relevant only for NTC Input 1/2 options.	<b>725</b>	uint16	0..1000 (x10)	0..100.0° Default 22°	R/W
Network Change-Over Override	Heating / Cooling Mode Command from Network. Note: Requires change-over source to be set as Network.	<b>726</b>	uint16	0..1 (x1)	0 = Heating (Default) 1 = Cooling	R/W

<b>FAN CONTROL</b>						
Fan Control Source	Sets the Temperature Source for the Fan Control Function.  Note: Options 7&8 from Fw1.21	<b>740</b>	uint16	0..8 (x1)	0 = Network Value (Reg 538) 1 = Heating Stage 1 2 = Heating Stage 2 3 = Cooling Stage 1 4 = Cooling Stage 2 5 = CO2 Demand 6 = Htg/Clg Stage 1 (Default) 7 = Htg1/Clg2 8 = Htg2/Clg1	R/W
Min Fan Speed	Sets the Minimum Fan Speed for EC Fans	<b>741</b>	uint16	0..100 (x1)	0..100% (Default 15%)	R/W
Fan Speed 1	Sets the Fan Speed 1 for EC Fans (when source 33%)	<b>742</b>	uint16	0..100 (x1)	0..100% (Default 33%)	R/W
Fan Speed 2	Sets the Fan Speed 2 for EC Fans (when source 66%)	<b>743</b>	uint16	0..100 (x1)	0..100% (Default 66%)	R/W
Fan Speed 3	Sets the Fan Speed 3 for EC Fans (when source 99%)	<b>744</b>	uint16	0..100 (x1)	0..100% (Default 100%)	R/W
Fan Mode	Sets the EC Fan Mode. Continuous Mode scales the fan demand based on the source and Fan Speed 1/2/3 settings. In Stepped mode the fan speed steps according to Fan Speed 1/2/3 settings.	<b>745</b>	uint16	0..1 (x1)	0 = Continuous Mode (Default) 1 = Stepped Mode	R/W
Fan Off Mode	Configures if the Fan is running at minimum level or is off when the fan control demand is at 0%. 1 - Minimum Speed: Running at Minimum Speed at Occupied and UnOccupied (0% in OFF mode). 2 - Minimum Occupied: Running at Min Speed in Occupied Only	<b>746</b>	uint16	0..2 (x1)	0 = Off (Default) 1 = Minimum Speed 2 = Minimum Occupied	R/W
Fan Off Delay	Switch OFF delay when the source demand drops to 0 (and Fan Off Mode is set to Off)	<b>747</b>	uint16	0..600 (x1)	0..600 seconds (Default 0)	R/W
Fan Start-Up Delay	Fan Start-Up when the source demand increases above 0%. During the delay the fan runs at Fan Speed 1 setting.	<b>748</b>	uint16	0..600 (x1)	0..600 seconds (Default 10)	R/W
Fan Level Override	Current Fan Level that can be set from the buttons or network (last command prevails). Note: If Fan Levels = 0-1-A, options 2, 3 and 4 override to Automatic control. Note: If Fan Levels = 0-1-2-A, then Level 2 overrides to Speed 3. Both 3 and 4 override to Automatic control	<b>749</b>	uint16	0..4	0.4 (Off / Speed1-2-3 / Auto)	R/W
Fan Levels	Set the Fan Levels for the network override and for the push button operation	<b>750</b>	uint16	0..2	0 = 0-1-A 1 = 0-1-2-A 2 = 0-1-2-3-A	
Fan Relay Delay	Set the switching delay between Fan Speeds 1, 2 and 3 when Fan Mode = Stepped.(from Fw 1.19) - xCR03 Only	<b>751</b>	uint16	0..30 (x1)	0..30 seconds (Default 0)	R/W
Max Auto Fan Speed	Maximum Fan Speed in Automatic Control Mode (from Fw 1.57)	<b>752</b>	uint16	0..100 (x1)	0..100% (Default 100%)	R/W

<b>AIR QUALITY CONTROL</b>						
CO2 Control Source	Sets the Source for the CO2 Control  Note: If set to UI1/UI2, then 0..10V is scaled to measurement according to UI Input Min/Max scaling parameters 523-526.	<b>760</b>	uint16	0..3 (x1)	0 = Network Value (Reg 539) 1 = Built-In CO2 (Default) 2 = UI1 - 0..10V 3 = UI2 - 0..10V	R/W
CO2 Setpoint	CO2 Control Setpoint	<b>761</b>	uint16	0..10000 (x1)	0..10,000 (Default 750)	R/W
CO2 PB	CO2 Control Proportional Band	<b>762</b>	uint16	1..10000 (x1)	1..10,000 (Default 500)	R/W
CO2 IA	CO2 Control Integral Action Time (Set to 0 to disable)	<b>763</b>	uint16	0..3600 (x1)	0..3600s (Default 0s)	R/W
CO2 Setpoint Setback	CO2 Control Setpoint SetBack in Unoccupied mode	<b>764</b>	uint16	0..2000 (x1)	0..2,000 (Default 0)	R/W
<b>BOOST</b>						

Boost Time	Sets the Boost Time. If set to 0, permanent boost, cancelled by pressing button again.	<b>682</b>	uint16	0..28,800 (x1)	0..28,800 secs 0 = default	R/W
Boost Target	Sets the Boost operation. Options 1..8 override the specific control outputs. Option 9 overrides the controller from Off/Unoccupied mode to Occupied mode.	<b>683</b>	uint16	0..9 (x1)	0 = None (default) 1 = Heating Stage 1 2 = Heating Stage 2 3 = Heating_All 4 = Cooling Stage 1 5 = Cooling Stage 2 6 = Cooling_All 7 = CO2 Demand 8 = Fan Demand 9 = Occupancy	R/W

SYSTEM AND COMMUNICATION SETTINGS						
Parameter	Description	Modbus Register / BACnet Property	MODBUS HOLDING REGISTER - FUNCTION CODES 03, 06, 16		Value Range / Enumerations	R/W
			Type	Data Range (multiplier)		
Address	Modbus Address BACnet MAC Address	<b>800</b>	uint16	1..247 (x1) 1..127 (x1)	Modbus: 1..247 BACnet: 1..127	R/W
Baud Rate	Baud Rate	<b>801</b>	uint16	0..5	0 = 9600 (default) 1 = 19200 2 = 38400 3 = 57600 4 = 76800 5 = 115200	R/W
Modbus Parity	Modbus Parity	<b>802</b>	uint16	0..2	0 = None (default) 1 = Odd 2 = Even	R/W
Modbus Stopbits	Modbus Stopbits	<b>803</b>	uint16	0..1	0 = 1 Stop Bit (default) 1 = 2 Stop Bits	R/W
Soft Reset	Soft Reset	<b>810</b>	uint16	0..1	0 = Normal 1 = Reset	R/W
Persist	Persist (Store Parameters in Non-Volatile Memory after changes) <b>NOTE: DO NOT WRITE FREQUENTLY TO THIS REGISTER. IT IS ONLY APPLIED AFTER CONFIGURATION CHANGES.</b>	<b>811</b>	uint16	0..1	0 = Normal 1 = Persist	R/W
Reload Defaults	Reload Defaults (NOTE: Resets all settings to factory defaults)	<b>812</b>	uint16	0..1	0 = Normal 1 = Factory Defaults	R/W
Service Pin	Service Pin (BACnet Only)	<b>813</b>	uint16	0..1	0 = Normal 1 = Service Pin	R/W
Language Pack Enable	Enables the Language Pack (using language pack it is possible to change the user text entries on the screen)	<b>814</b>	uint16	0..1	0 = English 1 = Language Pack Enabled	R/W
Firmware Version	Firmware Version	<b>820</b>	uint16	N/A	N/A	R
Serial Number	Serial Number	<b>821</b>	uint16	N/A	N/A	R
Date Code	Date Code	<b>822</b>	uint16	N/A	N/A	R
Product ID	Product ID	<b>823</b>	uint16	N/A	N/A	R
Device ID	BACnet Device ID. Set to 0 to use Automatically generated ID. Follow change with "Persist" and "Reset".	<b>825</b>	uint32	0..4,194,303 (x1)	0..4,194,303	R/W

The following registers are available with Modbus only. The registers combine two parameters to a single 16-bit (2 Bytes) Modbus register.

MODBUS SPECIFIC COMBINATION REGISTERS						
Parameter	Description		MODBUS INPUT REGISTERS - FUNCTION CODE 04 MODBUS HOLDING REGISTER - FUNCTION CODES 03, 16			
			Type	Data Range (multiplier)	Value Range / Enumerations	R/W
Y1/Y2	Combined 16-Bit Register for Outputs Y1 and Y2. E.g. Y1=0x64 (100%), Y2=0x64 (100%) Register=0x6464 (25700)	<b>450</b>	uint16	0..25700 (x1) 0x0000..0x6464	Byte 1:Y1 (0x00..0x64), Byte 2:Y2 (0x00..0x64)	R
Y3	Combined 16-Bit Register for Outputs Y3	<b>451</b>	uint16	0..25700 (x1) 0x0000..0x6464	Byte 1: Y3 (0x00..0x64),	R

Htg/Clg	Combined 16-Bit Register for Heating and Cooling Demands	452	unit16	0..25700 (x1) 0x0000..0x6464	Byte 1: Htg (0x00..0x64), Byte 2: Clg (0x00..0x64)	R
Triac1/Triac2	Combined 16-Bit Register for Triac 1 and Triac 2 Demands	453	unit16	0..25700 (x1) 0x0000..0x6464	Byte 1: Triac 1 (0x00..0x64) Byte 2: Triac 2 (0x00..0x64)	R
Y1 Commission Override	Y1 Commissioning Override Parameter	690	uint16	0..3 (x1)	0 = Auto (Default) 1 = Manual Override 2 = 0% 3 = 100%	R/W
Y2 Commission Override	Y2 Commissioning Override Parameter	691	uint16	0..3 (x1)		R/W
Y3 Commission Override	Y3 Commissioning Override Parameter	692	uint16	0..3 (x1)		R/W
TR1 Commissioning Override	TR1 Commissioning Override Parameter	694	uint16	0..3 (x1)	0 = Auto (Default) 1 = Manual Override 2 = 0% 3 = 100%	R/W
TR2 Commissioning Override	TR2 Commissioning Override Parameter	695	uint16	0..3 (x1)		R/W

## Bacnet Protocol Implementation Statement (PICS) and BACnet Objects

The -BAC versions of the controllers come with BACnet MS/TP communication. The following tables describe the PICS (Protocol Implementation Conformance Statement) and BACnet Objects (Standard and Proprietary). The Proprietary Objects are used for the device configuration.

GENERAL INFORMATION	
<b>Date:</b>	Feb 1, 2023
<b>Vendor Name:</b>	Senticon Ltd
<b>Vendor ID:</b>	1374
<b>Product Name:</b>	xCR Smart Room Controller
<b>Product Models:</b>	TCRxx, QCRxx
<b>Applications Software Version:</b>	1.0
<b>Firmware Revision:</b>	1.0.0
<b>BACnet Prorocol Revision</b>	1.19
<b>Product Description:</b>	Smart Room Sensors
<b>BACnet Standard Device Profile:</b>	BACnet Application Specific Controller (B-ASC)
<b>BACnet Interoperability Blocks Supported:</b>	Data Sharing - ReadProperty-B (DS-RP-B) Data Sharing - ReadPropertyMultiple-B (DS-RPM-B) Data Sharing - WriteProperty-B (DS-WP-B) Data Sharing - COV-B (DS-COVU-B) Device Management - DynamicDeviceBinding-B (DM-DDB-B) Device Management - DynamicObjectBinding-B (DM-DOB-B) Device Management - DeviceCommunicationControl-B (DM-DCC-B)
<b>Segmentation Capability:</b>	No
<b>Data Link Layer Options:</b>	MS/TP Master; Supported Baud 9600/19200/38400/57600/76800/115200
<b>Device Address Binding:</b>	No static device binding supported
<b>Networking Options:</b>	None
<b>Character Sets Supported:</b>	ISO 10646 (UTF-8)
<b>Gateway Options:</b>	None
<b>Network Security Options:</b>	Non-Secure Device

Standard Object Types Supported:	Object Type:	Optional Properties	Writeable Properties
	Analog Value:	Description, COV Increment, Relinquish Default	Present Value COV Increment
	Binary Value:	Description, Inactive_Text, Active_Text	Present Value
	Device Object:	Description Active COV Subscriptions Max Master	Object Identifier Object Name APDU Timeout (0...60000) Number Of APDU Retries (0...10) Max Master (1...127)
<p><i>For all supported objects, device does not support CreateObject or DeleteObject.</i></p> <p><i>For Analog Value objects that are classified as read only, there is the following behavior:</i></p> <ul style="list-style-type: none"> <li>- HVAC application overwrites the present value that has been written with the Write Property Service.</li> <li>- In this case, no error message will be sent.</li> </ul> <p><i>The device application checks the ranges of the Present Value and the COV Increment of the Analog Objects. For this reason, there is the following behavior:</i></p> <ul style="list-style-type: none"> <li>- No error message, if the limits have been exceeded</li> <li>- Too high values are set to the range maximum</li> <li>- Too small values are set to the range minimum</li> </ul>			

OBJECT TYPE: DEVICE OBJECT				
Object Instance	Property Identifier	Value Range	Default Value	R/W
Device[x]	Object Identifier		MAC_Address	R/W
	Object Name	32 chars max.		R/W
	Object_Type		8	R
	System_Status		Status_Operational	R
	Vendor_Name		Senticon Ltd	R
	Vendor_Identifier		1374	R
	Model_Name		xER	R
	Firmware_Revision		1.0.0	R
	Application_Software_Version		1.0	R
	Protocol_Version		1	R
	Protocol_Revision		19	R
	Protocol_Services_Supported		See General Information	R
	Protocol_Object_Types_Supporte		See General Information	R
	Object_List		See Objects List	R
	Max_APDU_Length_Accepted		480	R
	Segmentation_Supported		No	R
	APDU_Timeout		6000 ms	R/W
	Number_Of_APDU_Retries		3	R/W
	Max_Master		127	R/W
	Device_Address_Binding			R
Database_Revision		0	R	
Property_List			R	

OBJECT TYPE: ANALOGUE VALUE						
Object Instance	Object Name	Value Range	Relinquish_Default	Units	COV Increment	R/W
AV(0)	Temperature	-40.0..120.0°C / -40.0..248.0°F	-	DEGREES_CELCIUS or DEGREES_FAHRENHEIT	0.0..100 (Default 0.5)	R
AV(1)	CO2	0...10,000	-	PARTS_PER_MILLION	0.0..100 (Default 50)	R
AV(2)	UI1	-40.0..120.0°C / -40..248°F 0..100.0%	-	DEGREES_CELCIUS or DEGREES_FAHRENHEIT or NO_UNITS	0.0..100 Default 1.0	R
AV(3)	UI2	-40.0..120.0°C / -40..248°F 0..100.0%	-	DEGREES_CELCIUS or DEGREES_FAHRENHEIT or NO_UNITS	0.0..100 Default 1.0	R

AV(4)	Y1	0.0..100.0%	-	PERCENT	5	R/W
AV(5)	Y2_RL1	0.0..100.0%	-	PERCENT	5	R/W
AV(6)	Y3_RL2	0.0..100.0%	-	PERCENT	5	R/W
AV(7)	Setpoint_Main	0.0..212.0	Nonvol_Setpoint	NO_UNITS	n/a	R/W
AV(8)	Setpoint_CO2	0..10000.0	Nonvol_Setpoint	PARTS_PER_MILLION	n/a	R/W
AV(9)	Fan_Speed	0..4.0	Nonvol_FanSpeed	NO_UNITS	1	R/W
AV(10)	Operating_Mode (Occupied/Unocc/Off)	0..2.0	Nonvol_OpMode	NO_UNITS	1	R/W
AV(11)	Network_Decimal	-999.0..999.0	Nonvol_Setpoint	NO_UNITS	n/a	R/W
AV(12)	Network_Integer	0..65535.0	Nonvol_Setpoint	NO_UNITS	n/a	R/W
AV(13)	Triac1_PWM	0..100	-	PERCENT	5	R/W
AV(14)	Triac2_PWM	0..100	-	PERCENT	5	R/W
AV(15)	RL3 (xCR03 only)	0.0..100.0%	-	PERCENT	5	R/W

**NOTE: Priority Input 16 is reserved for internal value. If COV increment is set to 0.0 (default), the COV is disabled.**

**NOTE: R = Read Only, R/W = Read/Write**

OBJECT TYPE: BINARY VALUE					
Object Instance	Object Name	Description	Present Value Range / Active - Inactive Tex	Relinquish_Default	R/W
BV(0)	DI_1	Digital Input 1 Status	0: InActive (Off) 1: Active (On)	Binary_Inactive	R
BV(1)	DI_2	Digital Input 2 Status	0: InActive (Off) 1: Active (On)	Binary_Inactive	R
BV(2)	Cooling_Mode	Cooling Mode Override for Stage 1 (Heating/Cooling Change-Over)	0: InActive 1: Active	Binary_Inactive	R/W
BV(3)	Occupancy	Occupancy	0: InActive 1: Active	Binary_Inactive	R
BV(4)	Boost	Boost Mode Status	0: InActive 1: Active	Binary_Inactive	R

**NOTE: Priority Input 16 is reserved for Internal Value.**

**NOTE: BV(6) - Set Priority Inputs 1-15 to 'null' to allow the user to unlock/lock the device.**

PROPRIETARY OBJECT OBJECT NAME / TYPE: "CONFIGx" / 128
The devices have six instances of proprietary Device Configuration objects split as with the configuration tools; Cfg_IO, Cfg_Calibration, Cfg_User_interface, Cfg_Control_1, Cfg_Control_2, Cfg_System. The devices can be fully configured using the properties of these configuration objects. Full list of available properties are listed in the <i>Device Setup and Modbus/BACnet Communication</i> section tables.

In addition to the generic parameters, the BACnet AV and BV objects have proprietary property to enable COV (Unsubscribed COV) function. For the AV objects the COV increment can be changed from the defaults. For the BV objects data is transmitted when the state changes.

**NOTE: Enabling COV increases network load as the messages are broadcasted to all devices. For efficient network performance limit the number of COV objects to minimal and configure routers to allow broadcasts only on the subnets.**

BACNET COV OBJECT SETTINGS						
Parameter	Description	BACnet Property	Type	Data Range (multiplier)	Value Range / Enumerations	R/W
AVx COV	AV Object COV Enable Flag x = AV Object Number (AV0..AV6, A9..AV10, AV13..AV14)	100x	uint16	0..1(x1)	0 = COV Disabled 1 = COV Enabled	R/W
BVx COV	BV Object COV Enable Flag x = BV Object Number (BV0..BV1)	110x	uint16	0..1(x1)	0 = COV Disabled 1 = COV Enabled	R/W

## Dimensions and Installation

The devices typically mounted on the flat wall surfaces or on the junction boxes. The enclosure has 56/60mm screw distance for standard mounting boxes.

### Installation Notes:

- Follow the diagram below to open the enclosure to access the mounting holes and the wiring terminals.
- Install the sensors away from the sources of heat and cool e.g. from direct sunlight or cold external walls.
- Install the sensors at 120-150 cm height for optimal performance.
- For correct movement (PIR) sensor operation consider the location of the sensor carefully.
- Make sure that the cable entries and junction boxes are sealed from air flows. This is the most common reason for inaccuracies in temperature measurement.
- Bring the cables through the dedicated hole (black area) marked on the dimensions drawing.
- If surface mounted cable is required to be used, the top of the enclosure (center) has a thin wall section that can be cut.

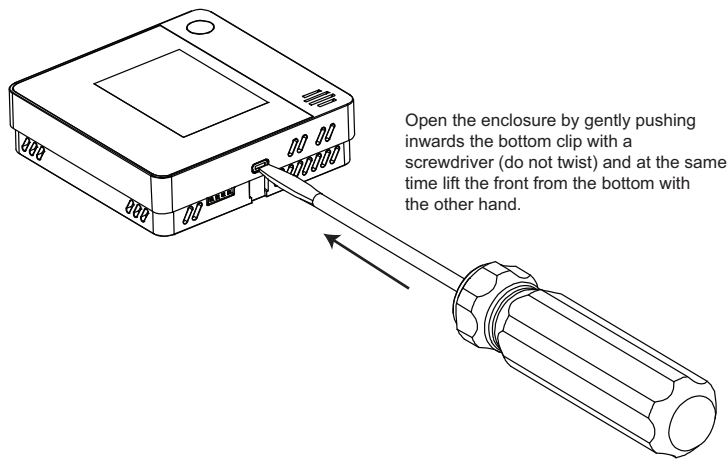

### DIMENSIONS

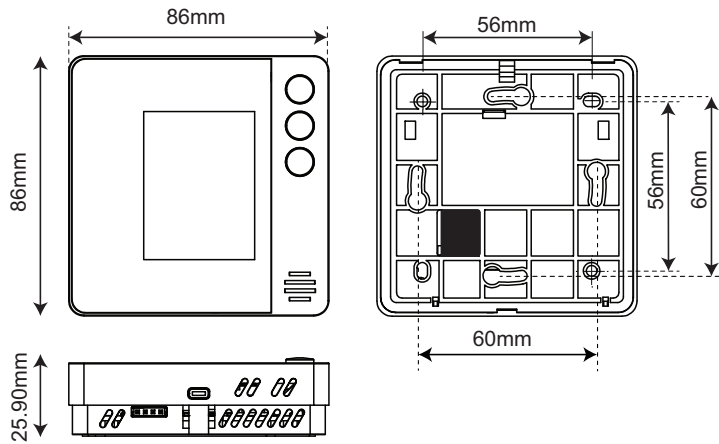

## DIMENSIONS (SLIMLINE TCR02/TCR03/QCR02/QCR03 SERIES)

